



PO54G374A, PO74G374A

54 & 74 Series Noise Cancellation GHz Logic

FEATURES:	DESCRIPTION:
<ul style="list-style-type: none"> Patented technology Specified From -40°C to 85°C, -40°C to 125°C, and -55°C to 125°C Operating frequency is faster than 600MHz VCC Operates from 1.65V to 3.6V Propagation delay $< 2.4\text{ns}$ max with 15pf load Low input capacitance: 4pf typical Latch-Up Performance Exceeds 250 mA Per JESD 17 ESD Protection Exceeds JESD 22 5000-VHuman-BodyModel (A114-A) 200-VMachineModel (A115-A) Available in 20pin TSSOP package Available in 20pin Ceramic Dual Flatpack Available in 20pin Leadless Ceramic Chip Carrier 	<p>Potato Semiconductor's PO74G374A is designed for world top performance using submicron CMOS technology to achieve higher than 600MHz TTL /CMOS output frequency with less than 2.4ns propagation delay.</p> <p>This dual Octal edge triggered D-type flip-flops are designed for 1.65-V to 3.6-V VCC operation.</p> <p>Inputs can be driven from either 3.3V or 5V devices. This feature allows the use of these devices as translators in a mixed 3.3V/5V system environment.</p>

Pin Configuration

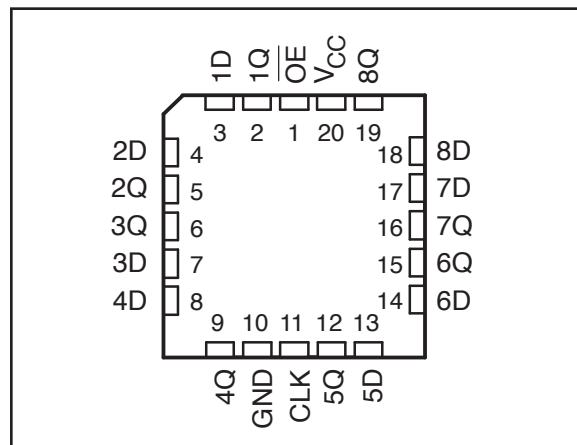
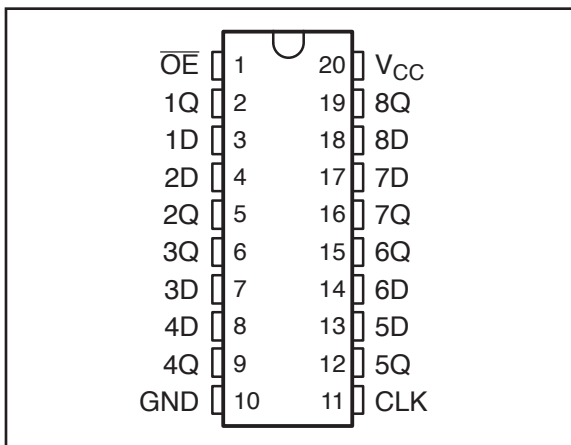

Pin Description

INPUTS			OUTPUT Q
OE	CLK	D	
L	↑	H	H
L	↑	L	L
L	H or L	X	Q_0
H	X	X	Z

Logic Block Diagram

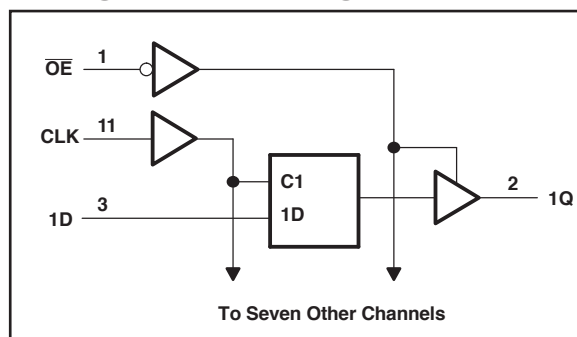

**54 & 74 Series Noise Cancellation GHz Logic****Maximum Ratings**

Description	Max	Unit
Storage Temperature	-65 to 150	°C
Operation Temperature	-55 to 125	°C
Operation Voltage	-0.5 to +4.6	V
Input Voltage	-0.5 to +5.5	V
Output Voltage	-0.5 to V _{cc} +0.5	V

Note:

stresses greater than listed under Maximum Ratings may cause permanent damage to the device. This is a stress rating only and functional operation of the device at these or any other conditions above those indicated in the operational sections of this specification is not implied. Exposure to absolute maximum rating conditions for extended periods may affect reliability specification is not implied.

DC Electrical Characteristics

Symbol	Description	Test Conditions	Min	Typ	Max	Unit
V_{OH}	Output High voltage	V _{cc} =3V Vin=V _{IH} or V _{IL} , I _{OH} = -12mA	2.4	3	-	V
V_{OL}	Output Low voltage	V _{cc} =3V Vin=V _{IH} or V _{IL} , I _{OH} =12mA	-	0.3	0.5	V
V_{IH}	Input High voltage	Guaranteed Logic HIGH Level (Input Pin)	2	-	5.5	V
V_{IL}	Input Low voltage	Guaranteed Logic LOW Level (Input Pin)	-0.5	-	0.8	V
I_{IH}	Input High current	V _{cc} = 3.6V and Vin = 5.5V	-	-	5	uA
I_{IL}	Input Low current	V _{cc} = 3.6V and Vin = 0V	-	-	-5	uA
V_{IK}	Clamp diode voltage	V _{cc} = Min. And I _{IN} = -18mA	-	-0.7	-1.2	V

Notes:

1. For conditions shown as Max. or Min., use appropriate value specified under Electrical Characteristics for the applicable device type.
2. Typical values are at V_{cc} = 3.3V, 25 °C ambient.
3. This parameter is guaranteed but not tested.
4. Not more than one output should be shorted at one time. Duration of the test should not exceed one second.
5. V_{OH} = V_{cc} - 0.6V at rated current

**54 & 74 Series Noise Cancellation GHz Logic****Power Supply Characteristics**

Symbol	Description	Test Conditions (1)	Min	Typ	Max	Unit
Iccq	Quiescent Power Supply Current	Vcc=Max, Vin=Vcc or GND	-	0.1	30	uA

Notes:

1. For conditions shown as Max. or Min., use appropriate value specified under Electrical Characteristics for the applicable device type.
2. Typical values are at Vcc = 3.3V, 25°C ambient.
3. This parameter is guaranteed but not tested.
4. Not more than one output should be shorted at one time. Duration of the test should not exceed one second.

Capacitance

Parameters (1)	Description	Test Conditions	Typ	Unit
Cin	Input Capacitance	Vin = 0V	4	pF
Cout	Output Capacitance	Vout = 0V	6	pF

Notes:

- 1 This parameter is determined by device characterization but not production tested.

Switching Characteristics

Symbol	Description	Test Conditions (1)	Max	Min	Unit
tsu	Setup time before CLK ↑		-	0.5	ns
th	Hold time, data after CLK ↑		-	0.5	ns
tPLH	Propagation Delay CLK to Q	CL = 15pF	2.4	-	ns
tPHL	Propagation Delay CLK to Q	CL = 15pF	2.4	-	ns
tpZH or tpZL	Output Enable Time	CL = 15pF		2.5	ns
tpHZ or tpLZ	Output Disable Time	CL = 15pF		2.5	ns
tr/tf	Rise/Fall Time	0.8V – 2.0V	0.8	-	ns
fmax	Input Frequency	CL=2pF - 15pF	-	600	MHz

Notes:

1. See test circuits and waveforms.
2. tPLH, tPHL, tsu, and th are production tested. All other parameters guaranteed but not production tested.
3. Airflow of 1m/s is recommended for frequencies above 500MHz



54 & 74 Series Noise Cancellation GHz Logic

Test Waveforms

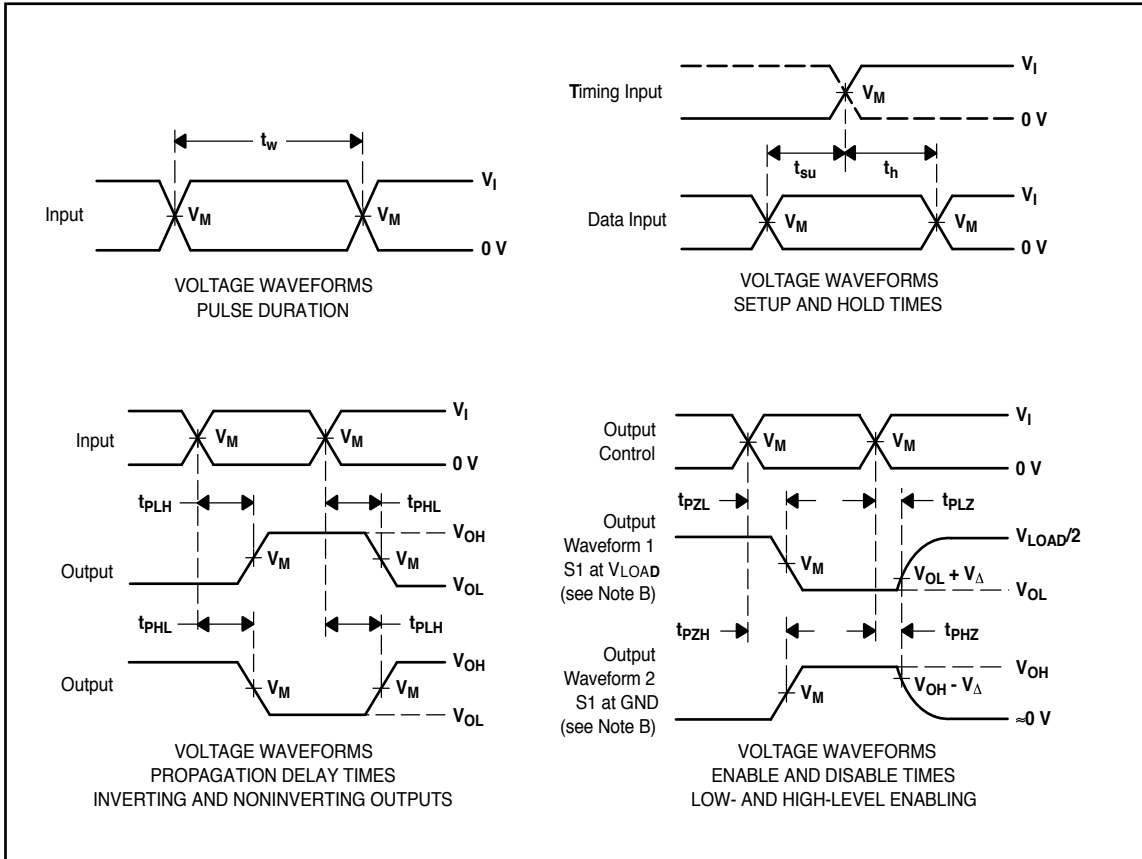

Test Circuit

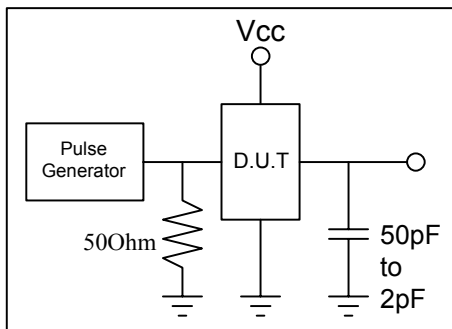



PO54G374A, PO74G374A

54 & 74 Series Noise Cancellation GHz Logic

Packaging Mechanical Drawing: 20 pin TSSOP

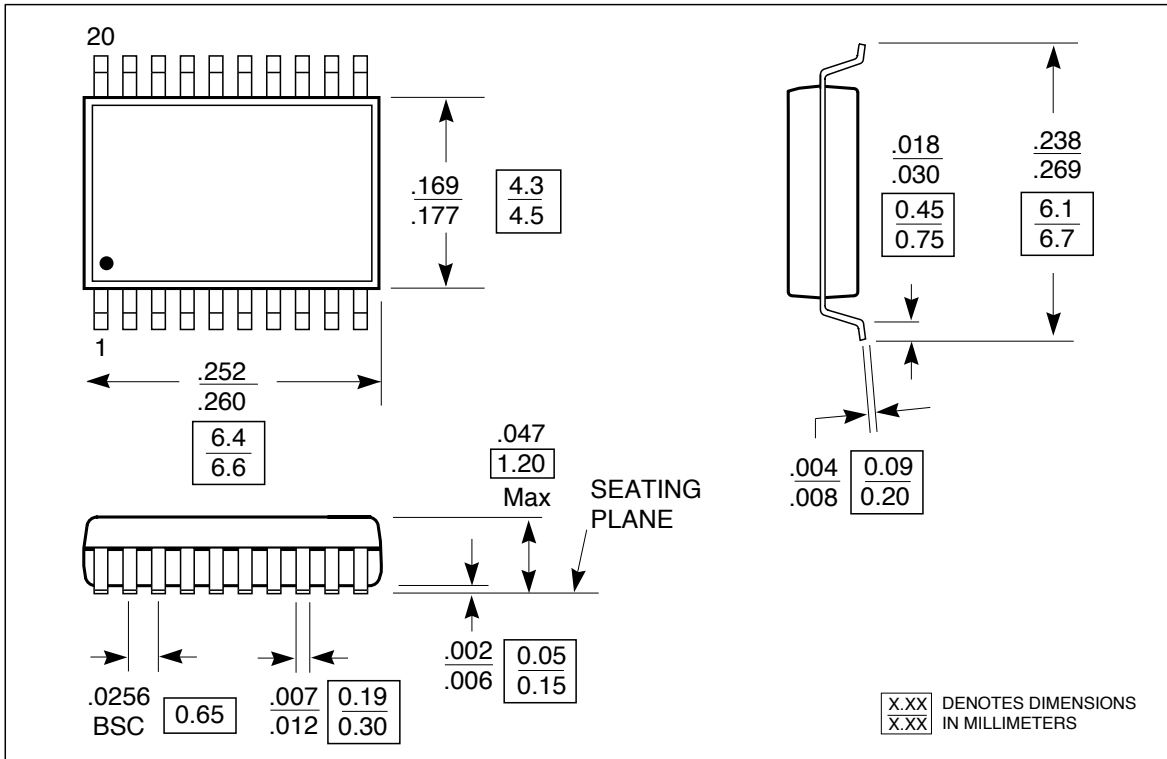

Packaging Mechanical Drawing: 20pin Leadless Ceramic Chip Carrier

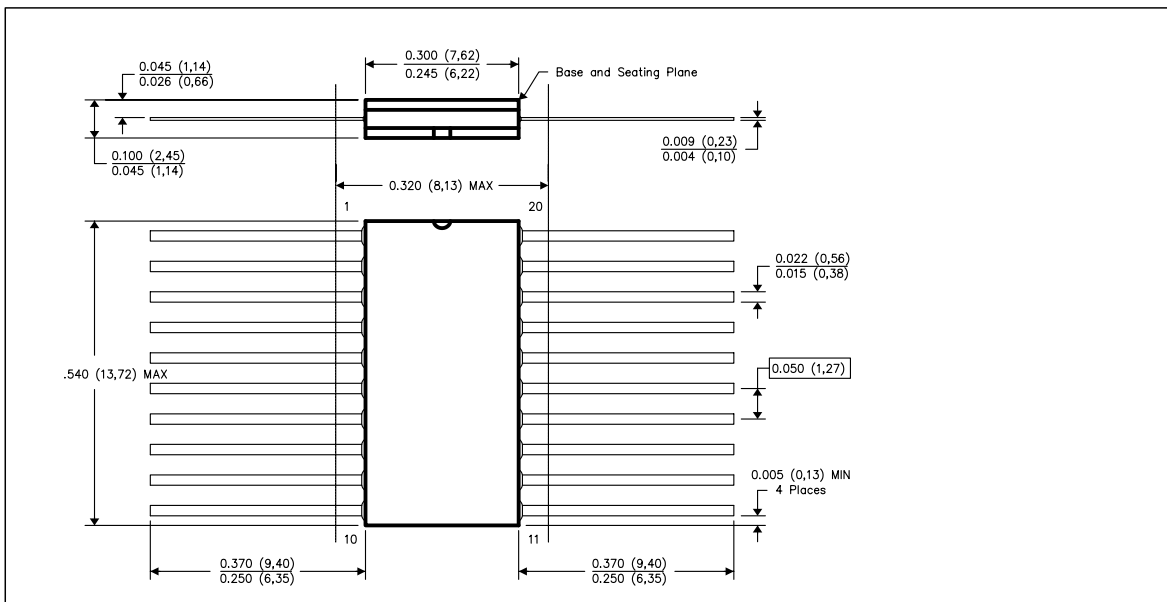



PO54G374A, PO74G374A

54 & 74 Series Noise Cancellation GHz Logic

Packaging Mechanical Drawing: 20pin Ceramic Dual Flatpack

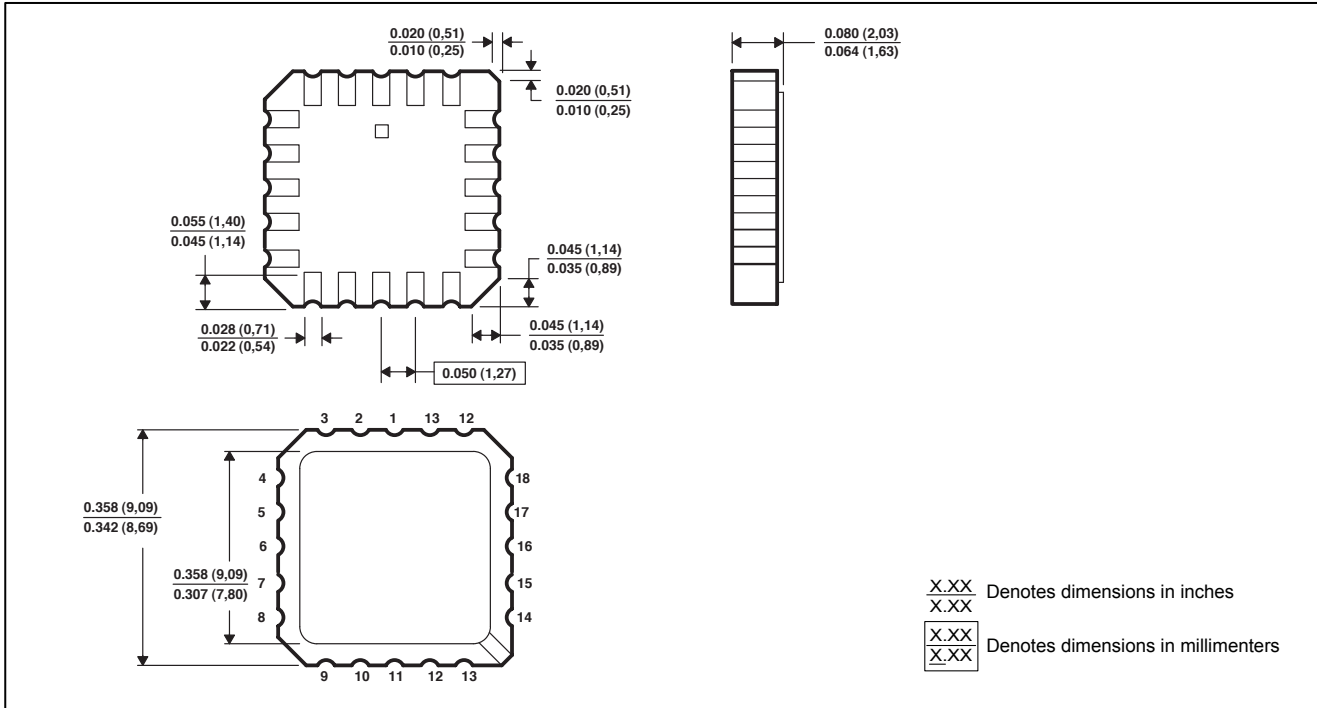

IC Ordering Information

Ordering Code	Package		Top-Marking	T _A
PO74G374ATU for Tube	20pin TSSOP	Pb-free & Green	POTATO74G374AT	-40°C to 85°C
PO74G374ATR for Tape & Reel	20pin TSSOP	Pb-free & Green	POTATO74G374AT	-40°C to 85°C
PO54G374ALU for Tube	20pin Leadless Ceramic Chip Carrier	Pb-free & Green	POTATO54G374AL	-55°C to 125°C
PO54G374AFU for Tube	20pin Ceramic Dual Flatpack	Pb-free & Green	POTATO54G374AF	-55°C to 125°C

IC Package Information

PACKAGE CODE	PACKAGE TYPE	TAPE WIDTH (mm)	TAPE PITCH (mm)	PIN 1 LOCATION	TAPE TRAILER LENGTH	QTY PER REEL	TAPE LEADER LENGTH	QTY PER TUBE
T	TSSOP 20	16	8	Top Left Corner	39 (12")	3000	64 (20")	74
L	LCCC 20	N/A	N/A	N/A	N/A	N/A	N/A	55
F	CFP 20	N/A	N/A	N/A	N/A	N/A	N/A	85