

Southco® Compression Latches

Over-center Lever Latch

- Designed for heavy-duty applications
- Provides consistent gasket compression
- Built-in leverage helps open stuck doors
- Padlock option

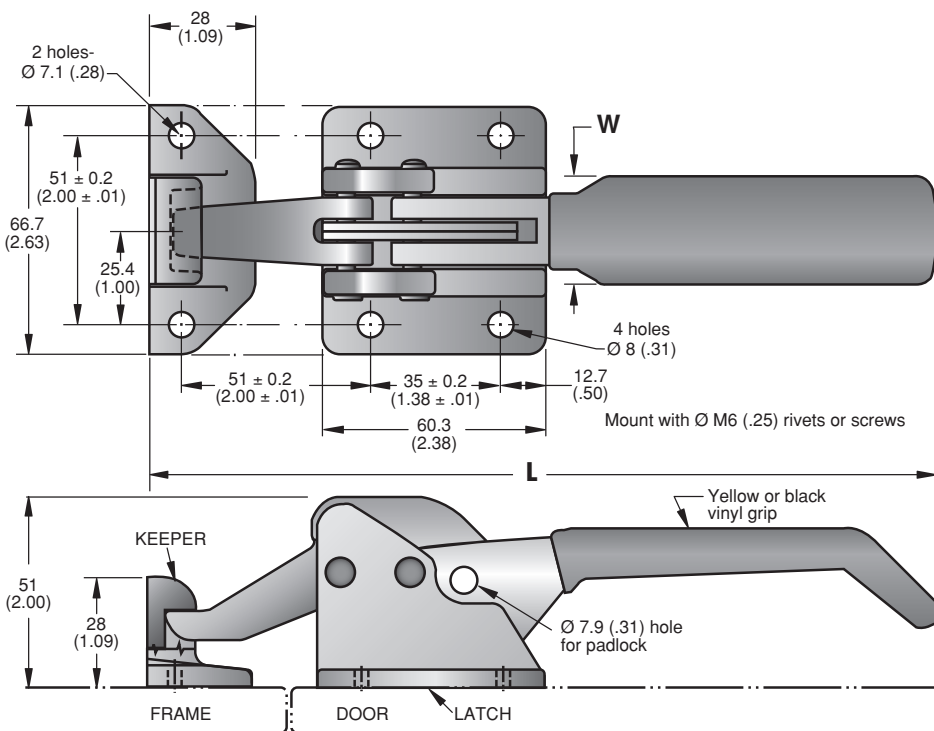

SHIM provided to make adjustments in latching plane of keeper when necessary.

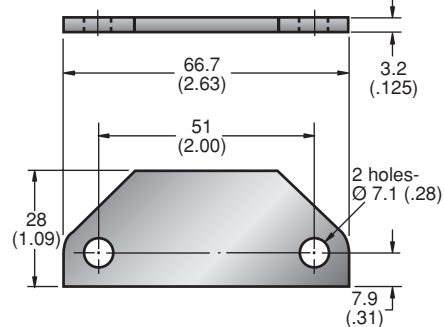

One supplied with each assembly.
For extra shims order part no.
A2-54-501-11.

STYLE	PART NUMBER	L	W
With plain handle	A2-10-501-10 •	211 (8.3)	25.4 (1.00)
With yellow vinyl handle grip	A2-10-501-22 •	214 (8.44)	30.2 (1.19)
With black vinyl handle grip	A2-10-501-21 •	214 (8.44)	30.2 (1.19)



Raise the handle; built in leverage applies a prying force against any rust, ice or paint that tries to resist opening.

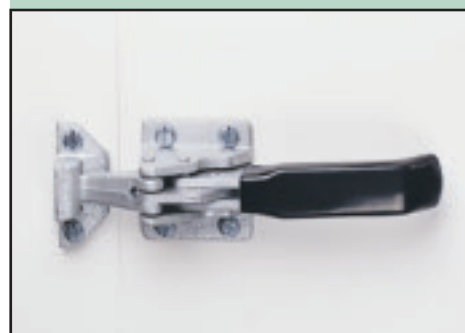

Close the door, push the handle down; the same linkage forces a secure closure regardless of dirt or corrosion.

Material and Finish

BASE, LEVER, PAWL and KEEPER:

Malleable iron.

LINKS: 1065 Steel.

MAIN CROSSPINS: 10B21 Steel.

Components listed above are DACROTIZED† plus bright metallic organic coating.

LINK PINS: 1215 Steel, zinc plated plus bright chromate dip.

SHIM: 1010 Steel, DACROTIZED† plus bright metallic organic coating.

SPRING: 302 Stainless steel, passivated.

OTHER PINS: 302 Stainless steel, passivated.

†Registered tradename of Metal Coatings International, Inc.

Product Strength Guidelines

(To assist in your product selection; samples are available for your evaluation.)

Maximum working load: 2220 N (500 lbs.)

Average ultimate load: 4450 N (1000 lbs.)

Latch is packaged one unit per box.

millimeter (inch)
millimeter (inch)

Dimensions without tolerances are for reference only.

