



E3 VISE ACTION® Compression Latch

Overview

Versatility and simplicity in action

Southco's VISE ACTION® Compression Latches provide mechanical advantage, ensuring tight, vibration resistant door closure to seal out water and dust, while allowing easy access with a choice of key and tool security options. The smooth operation of the VISE ACTION® design aligns the cam behind the frame and draws it up tight with a single continuous half-turn motion.



Environmental Sealing

Provides consistent compression to seal out water and dust

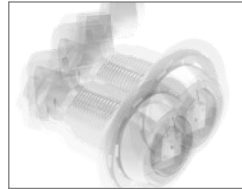

Vibration Resistant

Helps reduce or eliminate noise and rattles caused by vibration



Secure Access

Many tool and key access styles restrict access and discourage vandalism



Simple Operation

Continuous half-turn motion aligns the cam and pulls the latch tight



User Friendly

Easy-to-grip knob and handle-actuated styles for quick, simple access



Customizable

Variety of shapes and sizes to accommodate different door/panel thickness

Technical Specifications

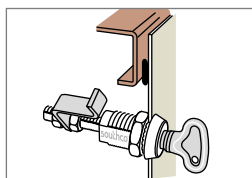
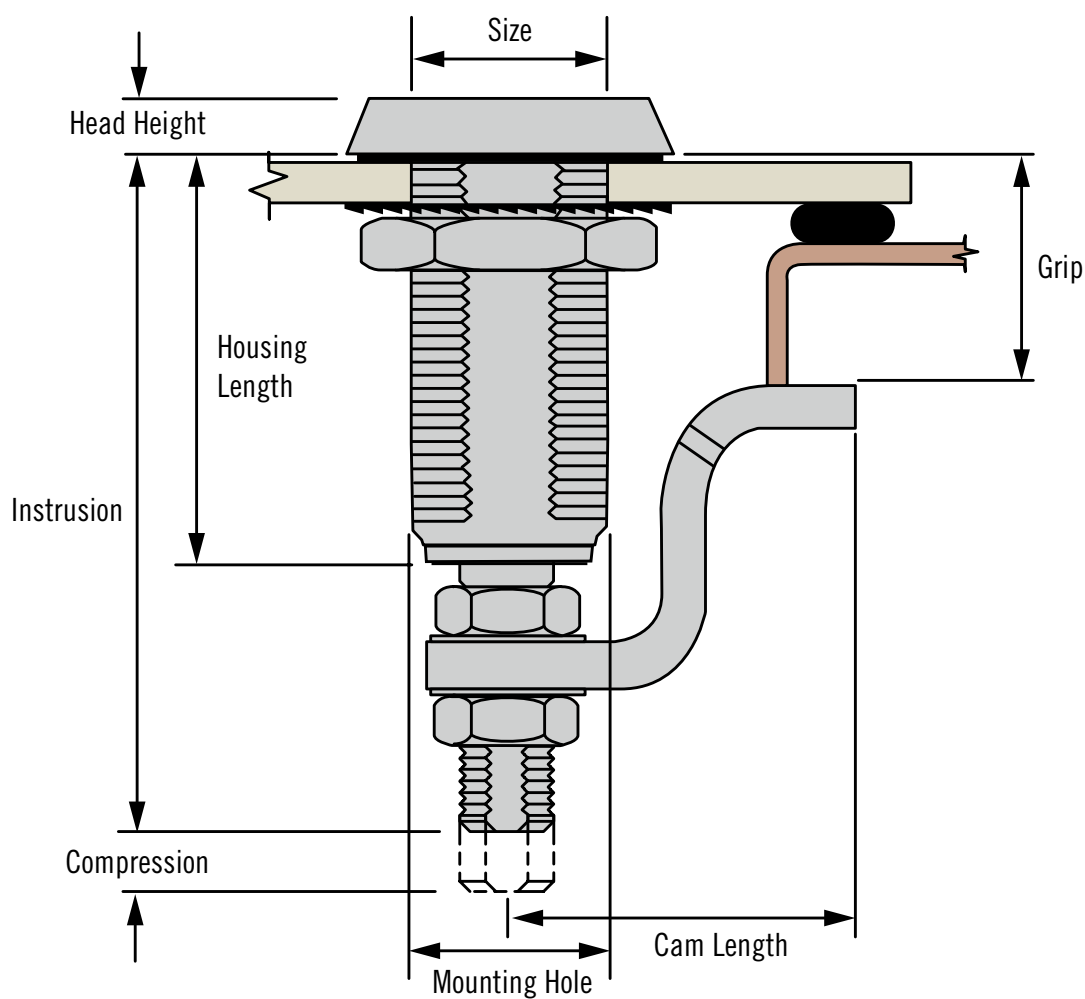

First 90° turn:
Cam rotates behind frame

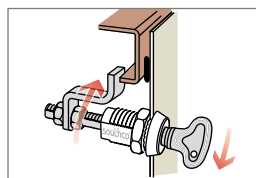

The door is now **latched**
against opening

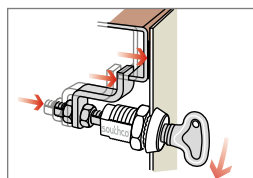

Completing the half-turn
motion, the shaft and cam
compress to pull the door
against the frame

Available Options

Material

Zinc, stainless steel, aluminum

Finish

Powder coating, chrome plating,
anodizing, passivation,
electropolishing

Grips

Fixed, adjustable

Size

Small (13.5mm mounting hole),
large (19.1mm mounting hole)

Rotation

Turn clockwise to latch,
turn counter-clockwise to latch

Access Restriction

None, tool, key locking, padlockable

Compliance Specifications

NEMA4, IP65/69K, UL, EN 44545-3,
DIN EN 1672-2, DIN EN61373



E3 VISE ACTION® Compression Latch

Zinc housing · Tool or hand operated
Fixed or adjustable grip · 19.1mm size

- Consistent pre-set compression
- Tool operated for security
- EN 45545-3 E10 Compliant

Material and Finish

Zinc alloy, powder coated or chrome plated and steel, zinc plated

Performance Details

Compression: 6.4 mm (.25 in)

Maximum static load:

Adjustable Grip: 450 N (100 lbf)

Fixed Grip: 300 N (67lbf)

Sealing Notes

NEMA 4 and IP65 enabled by using optional flange gasket (part number E5-17)

Installation Notes

Recommended tightening torque for the mounting nut is 20 N-m (176 in-lbf)

Adjustable Grip: Position cam so latching function can be achieved comfortably by hand.

Fixed Grip: Mounting screw torque 10 N-m (88 in-lbf)

Keys and Accessories

See pages 118-121

FIXED GRIP

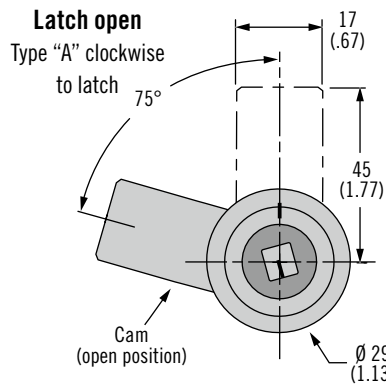
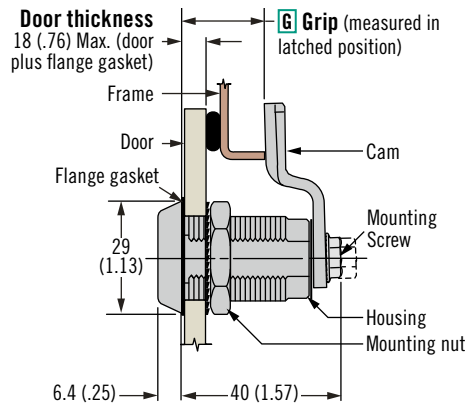

ADJUSTABLE GRIP

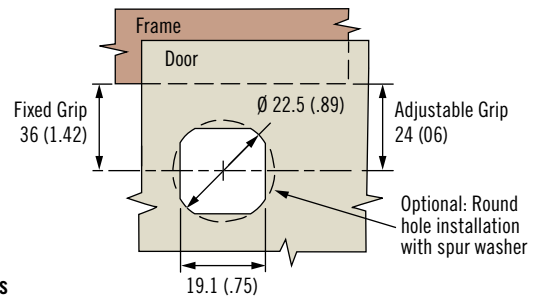
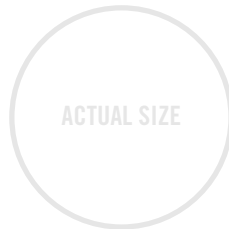
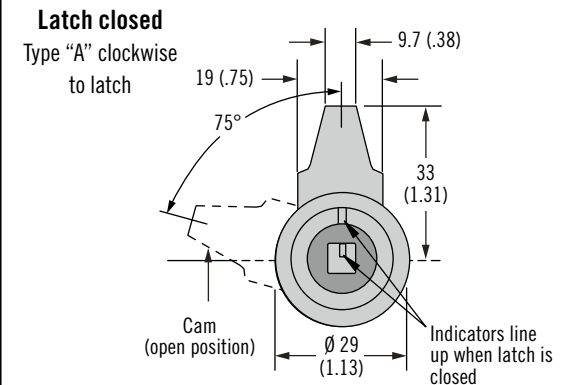
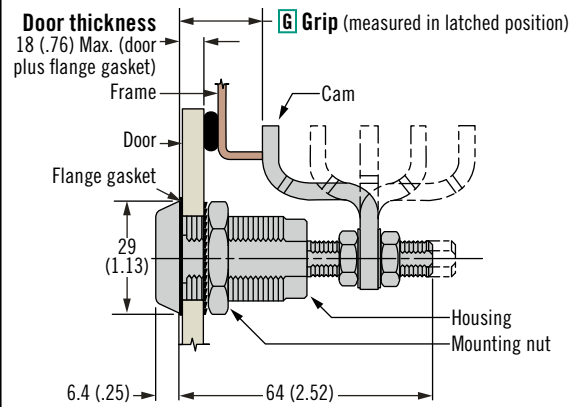

Railway Standard - Bellcore 216

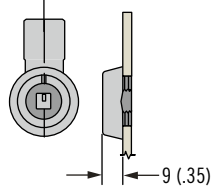

Other tool head styles (Slotted recess shown)

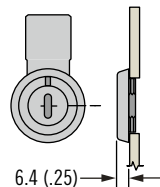

T-Handle Style

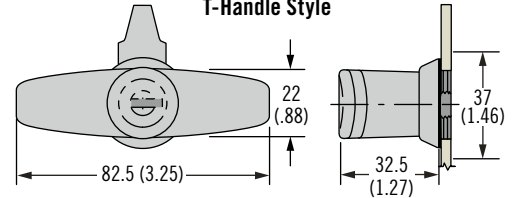

Knob Style

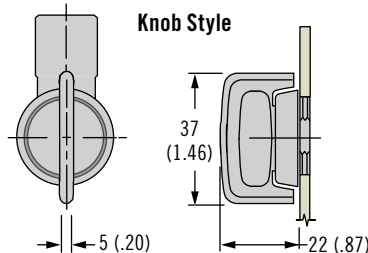

Wing Knob Style

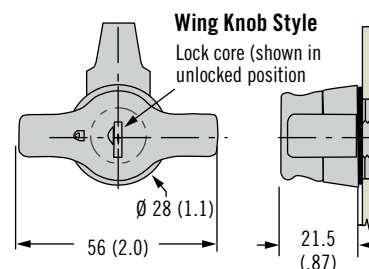

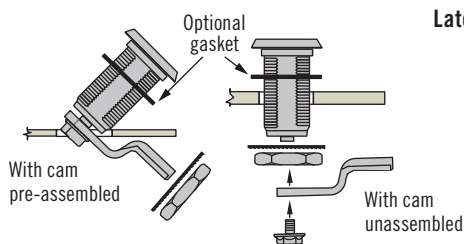

Latch Installation Method

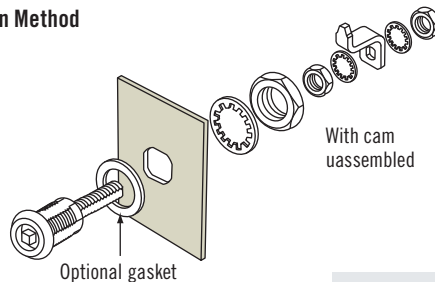

Part Number Selection

E3 - R H - G F

F Finish

- 1 Chrome plated
- 5 Black powder coated
- 7 Silver powder coated

H Head Styles

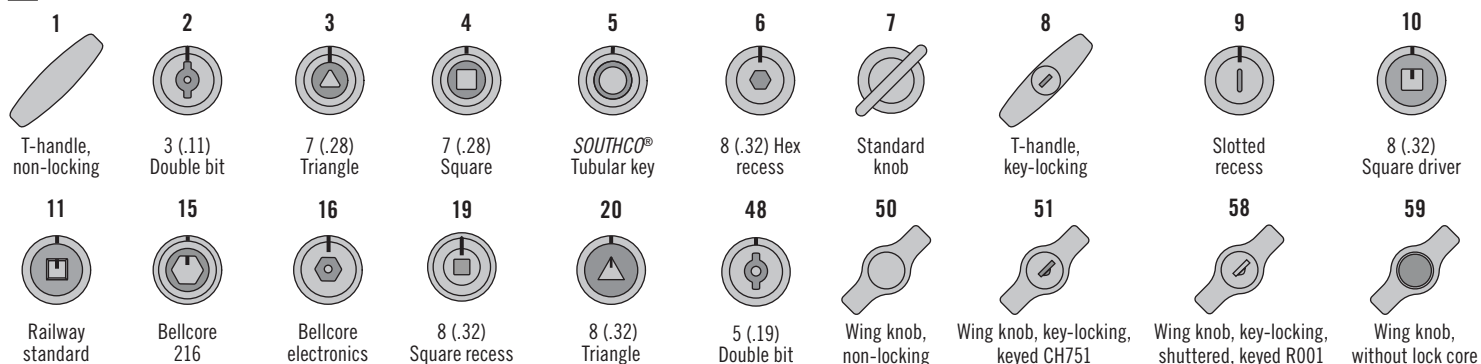

FIXED GRIP

R Rotation

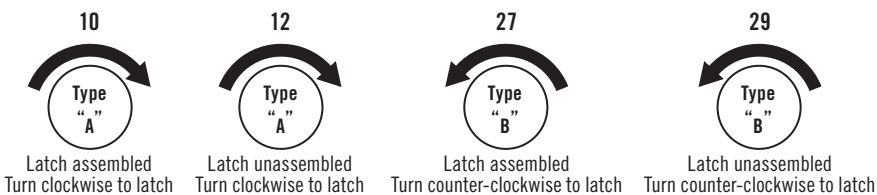

ADJUSTABLE GRIP

R Rotation

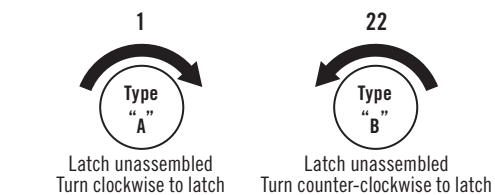

G Grip Table

Total Grip	G	Maximum Door Thickness with Cam Preassembled	Total Grip	G	Maximum Door Thickness with Cam Preassembled
15 (.59)	00	Use unassembled	35 (1.38)	10	7 (.28)
17 (.67)	01	Use unassembled	37 (1.46)	11	
19 (.75)	02	1 (.04)	39 (1.53)	12	
21 (.83)	03	2 (.08)	41 (1.61)	13	
23 (.91)	04	4 (.16)	43 (1.69)	14	
25 (.98)	05	5 (.20)	45 (1.77)	15	
27 (1.06)	06	6 (.24)	47 (1.85)	16	7 (.28)
29 (1.14)	07	7 (.28)	49 (1.93)	17	
31 (1.22)	08		51 (2.01)	18	
33 (1.30)	09		53 (2.09)	19	

For Fixed Grip, if your grip is between two options choose the smaller grip

G Grip Table

G Grip	Minimum	Maximum	Cam Type
1	11.4 (.45)	27.2 (1.07)	Deep offset cam, forward
	66.3 (2.61)	76.2 (3.00)	Deep offset cam, reversed
2	25.4 (1)	41.1 (1.62)	Offset cam, forward
	52.6 (2.07)	68.3 (2.69)	Offset cam, reversed
3	38.9 (1.53)	54.6 (2.15)	Straight cam

Dimensions in millimeters (inch) unless otherwise stated



E3 VISE ACTION® Compression Latch

Zinc housing · Tool operated

Compact · Fixed or adjustable grip · 19.1mm size

- Minimal panel intrusion
- Consistent pre-set compression
- Tool operated for security
- EN 45545-3 E10 Compliant

Material and Finish

Zinc alloy, powder coated or chrome plated and steel, zinc plated

Performance Details

Compression: 6.4 mm (.25 in)

Maximum static load:

Adjustable Grip: 450N (100 lbf)

Fixed Grip: 300N (67lbf)

Sealing Notes

NEMA 4 and IP65 enabled by using supplied flange gasket

Installation Notes

Recommended tightening torque for the mounting nut is 20 N·m (176 in·lbf)

Adjustable Grip: Position cam so latching function can be achieved comfortably by hand.

Fixed Grip: Mounting screw torque 10 N·m (88 in·lbf)

Keys and Accessories

See pages 118-121

FIXED GRIP

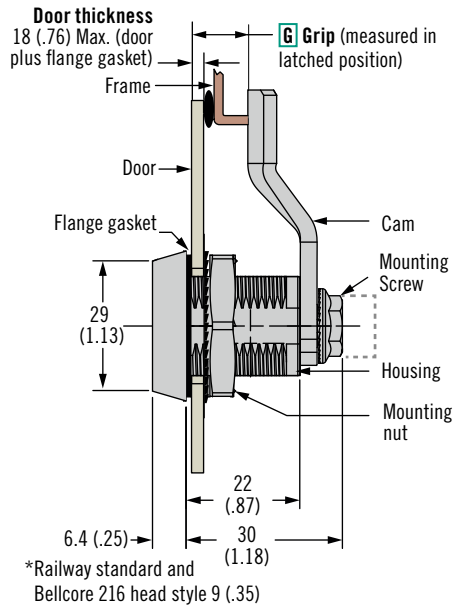

ADJUSTABLE GRIP

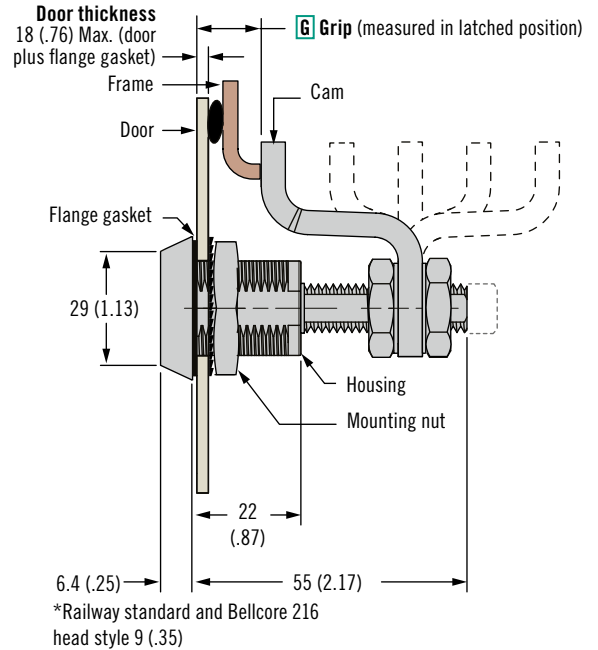

Latch open

Type "A" clockwise to latch

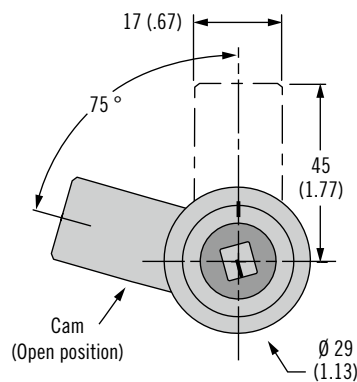

Latch closed

Type "A" clockwise to latch

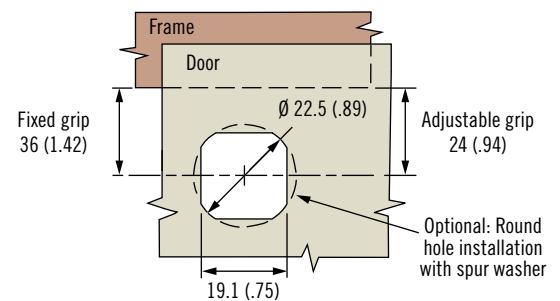
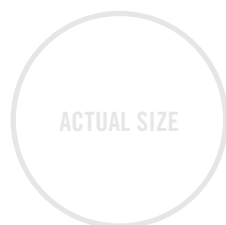
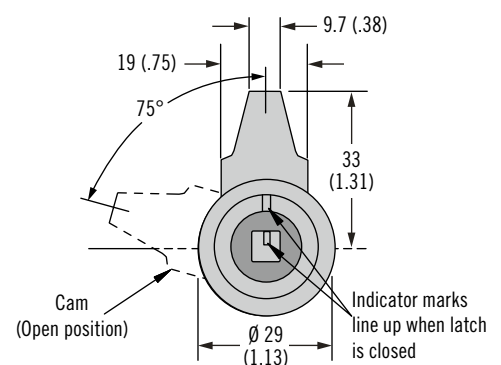

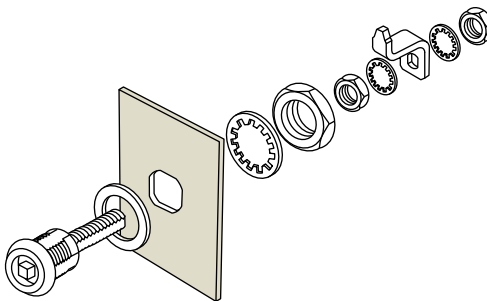
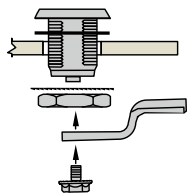

FIXED GRIP

E3 - C R H - UU F

ADJUSTABLE GRIP

E3 - C R H - O F

- F** Finish
 1 Chrome plated
 5 Black powder coated
 7 Silver powder coated

H Head Styles

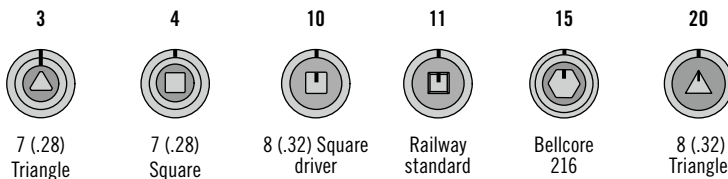

R Rotation

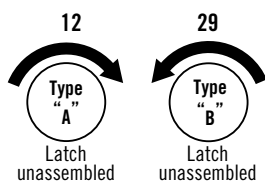

R Rotation

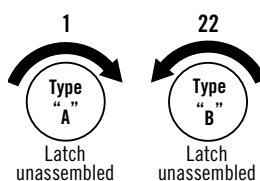

Part Number Selection

Rotation Option

Type A: Turn clockwise to latch
 Type B: Turn counter-clockwise to latch

Cam Part Number (order separately from latch)			
Grip	Part Number	Grip	Part Number
4 (.16)	E5-2500	24 (.94)	E5-2510
6 (.24)	E5-2501	26 (1.02)	E5-2511
8 (.31)	E5-2502	28 (1.10)	E5-2512
10 (.39)	E5-2503	30 (1.18)	E5-2513
12 (.47)	E5-2504	32 (1.26)	E5-2514
14 (.55)	E5-2505	34 (1.34)	E5-2515
16 (.63)	E5-2506	36 (1.42)	E5-2516
18 (.71)	E5-2507	38 (1.50)	E5-2517
20 (.79)	E5-2508	40 (1.57)	E5-2518
22 (.87)	E5-2509	42 (1.65)	E5-2519

Minimum Grip	Maximum Grip	Cam Type	Part Number
3.3 (.13)	14.7 (.58)	Deep offset cam, forward	E3-28-201-12
56.6 (2.23)	66.6 (2.62)	Deep offset cam, reversed	
14.6 (.57)	30.3 (1.19)	Offset cam, forward	E3-28-202-12
42 (1.65)	57.7 (2.27)	Offset cam, reversed	
28.2 (1.13)	44.5 (1.75)	Straight cam	E3-28-203-12

See table
 Order latch and cam separately.
 Select grip from Cam table if your grip is between two options choose the smaller grip





E3 VISE ACTION® Compression Latch

Zinc housing · Tool or hand operated

Adjustable grip · 13.5mm size

- Reduced dimensions
- Consistent pre-set compression
- Easy grip adjustment
- Tool operated for security
- EN 45545-3 E10 Compliant

Material and Finish

Zinc alloy, powder coated or chrome plated and steel, zinc plated

Performance Details

Compression: 4.3 mm (.17 in)

Maximum static load: 330 N (75 lbf)

Sealing Notes

NEMA 4 and IP65 enabled by using optional flange gasket (part number E3-0-30268-02)

Installation Notes

Recommended tightening torque for the mounting nut is 20 N·m (176 in-lbf)

Position cam so latching function can be achieved comfortably by hand.

Keys & Accessories

See pages 118-121

Part Number Selection

See table

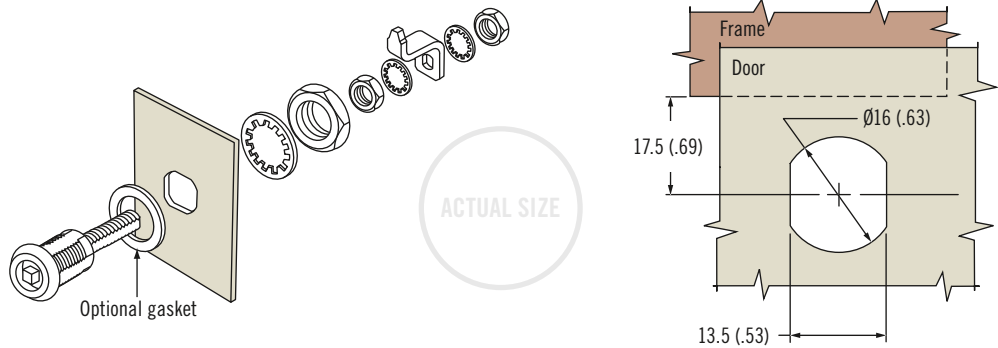
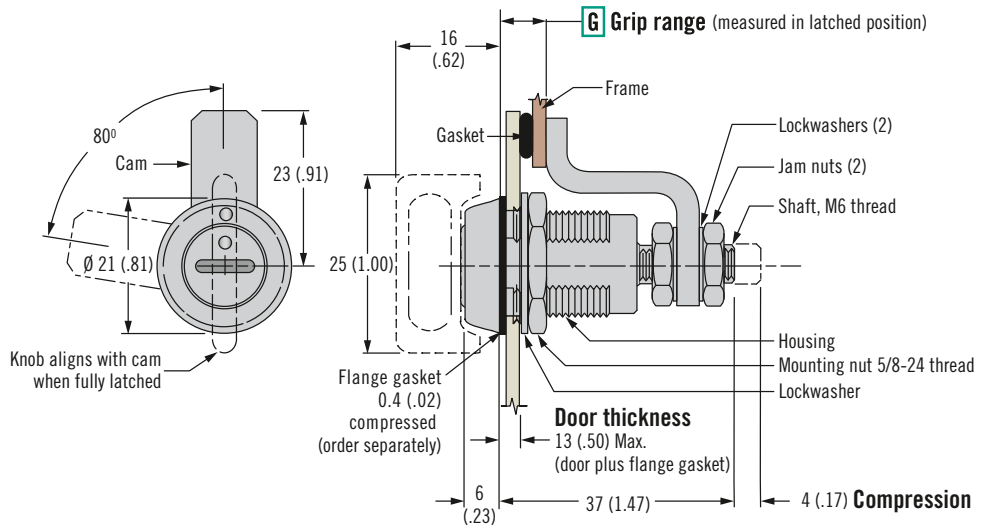

E3 - R H - G F

H Head Styles

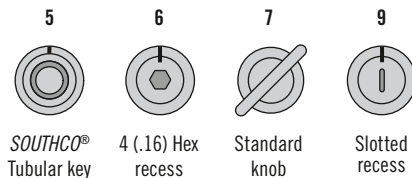

F Finish

- 1 Chrome plated
- 5 Black powder coated
- 7 Silver powder coated

R Rotation

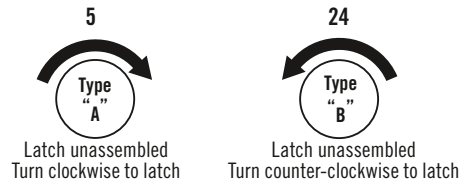

G Grip	Minimum	Maximum
1	3.2 (.13)	6.4 (.25)
2	6.4 (.25)	9.5 (.37)
3	9.5 (.37)	12.7 (.50)
4	12.7 (.50)	15.9 (.63)
5	15.9 (.63)	19 (.75)
6	19 (.75)	22.2 (.87)
7	22.2 (.87)	25.4 (1)
8	25.4 (1)	28.6 (1.13)

E3 VISE ACTION® Compression Latch

Zinc housing · Tool or hand operated
Three hole mount · Adjustable grip · 19.1mm size

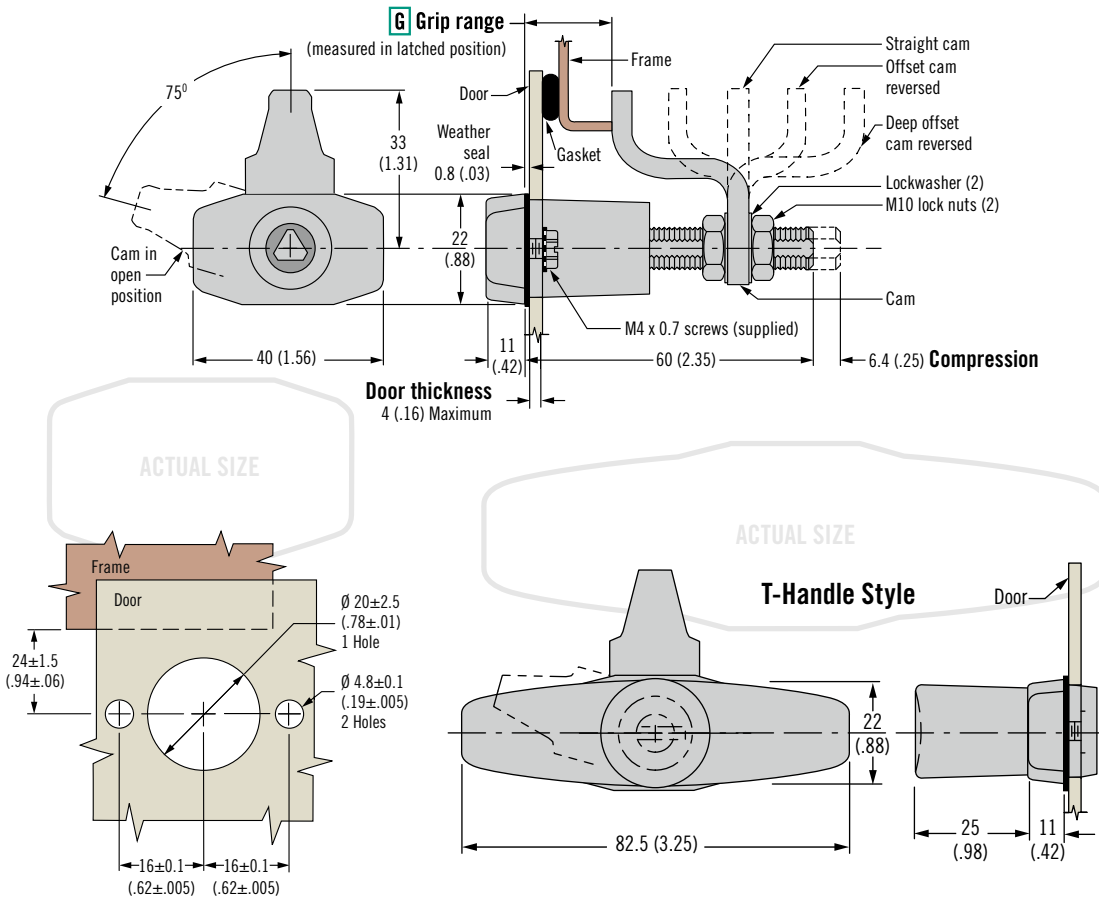

- For thick panel or soft material
- Consistent pre-set compression
- Easy grip adjustment
- Simplified round hole prep
- Tool operated for security

Material and Finish

Zinc alloy, powder coated or chrome plated and steel, zinc plated

Performance Details

Compression: 6.4 mm (.25 in)
Maximum static load: 450 N (100 lbf)

Installation Notes

For door thickness greater than 4 (.16) calculate screw length using the following formula:
Door thickness + 6 (.24)

Keys and Accessories

See pages 118-121

Part Number Selection

E3 - R H - G F

H Head Styles

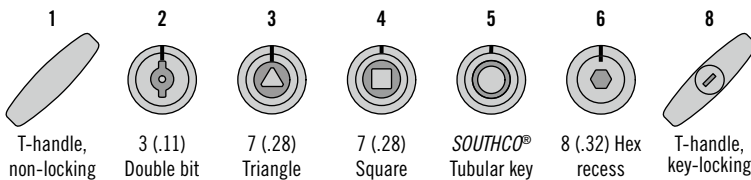

R Rotation

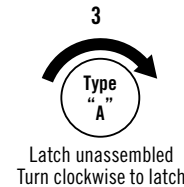

G Grip	Minimum	Maximum	Cam Type
1	7.9 (.31)	23.6 (.93)	Deep offset cam, forward
	62.7 (2.47)	76.2 (3.00)	Deep offset cam, reversed
2	21.8 (.86)	37.3 (1.47)	Offset cam, forward
	49 (1.93)	64.8 (2.55)	Offset cam, reversed
3	35.3 (1.39)	50.8 (2.00)	Straight cam

F Finish

- 1 Chrome plated
- 5 Black powder coated
- 7 Silver powder coated



E3 VISE ACTION® Compression Latch

Zinc housing · Tool operated

Flush · Fixed grip · 22.0mm size

- Completely flush outer surface
- Consistent pre-set compression
- Designed for thicker panels such as wood
- Tool operated for security

Material and Finish

Zinc alloy, powder coated or chrome plated and steel, zinc plated

Performance Details

Compression: 6.4 mm (.25 in)

Maximum static load: 300 N (67 lbf)

Installation Notes

1. Insert the latch through the rear of the door. Place the mounting washer then the mounting nut onto the latch.
2. Adjust mounting nut so that the head of the latch is flush with the outside of the door. The holes in the washer and the nut must be aligned. The latch must be aligned to the latching position. Southco recommends using a minimum of three mounting screws in a pattern shown. Recommended tightening torque for pawl mounting screw is 10 N-m (88.5 in-lbf).

Keys & Accessories

See pages 118-121

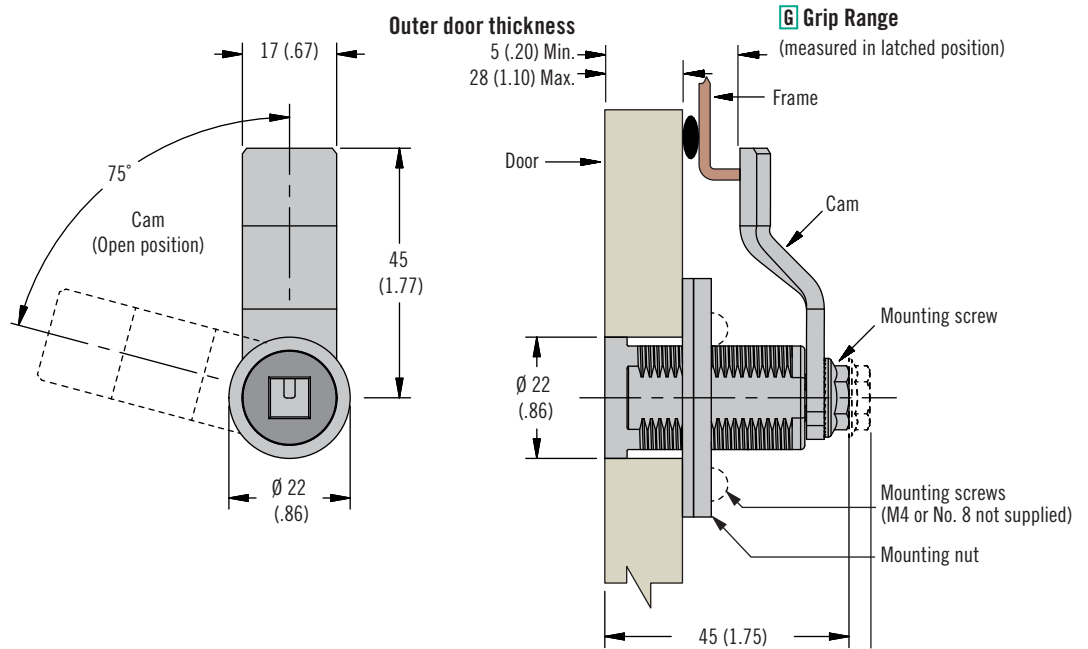

Cam Detail

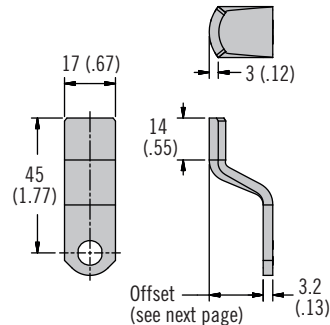

Mounting Washer

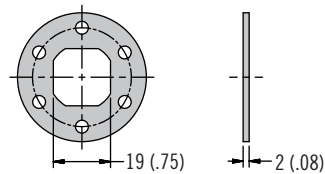

Mounting Nut

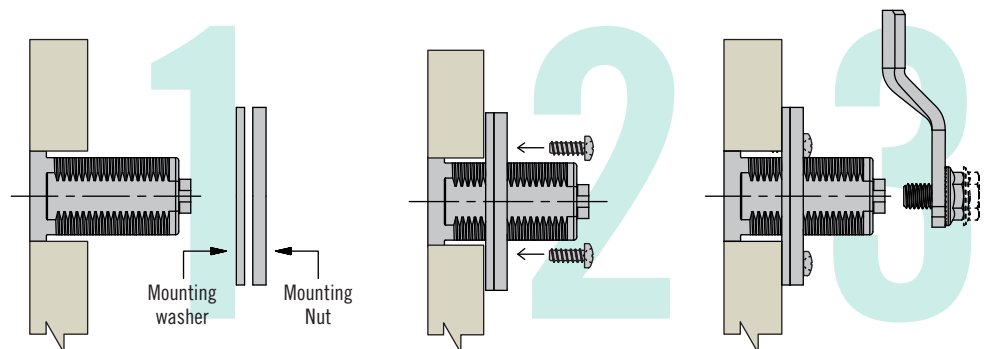
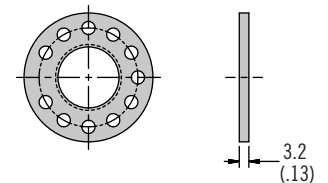

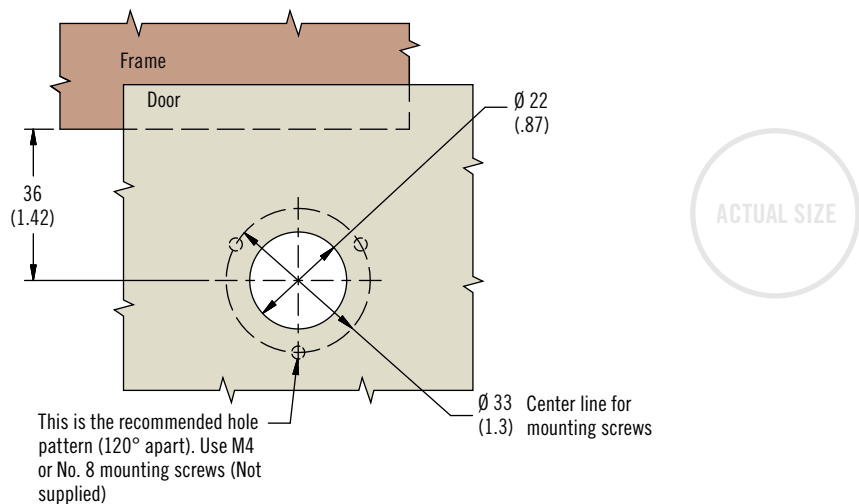

Part Number Selection

See table
 Select grip from table. If your grip is between two options choose the smaller grip
 Latches are individually packaged.
 For layer packaged latches (50 pieces minimum, sold in multiples of 50) add -13 to the part number.
 Example: E3-1410-XX1-13
 *10 (.375) Hex key not available from Southco

H Head Styles

- 3**



7 (.28)
Triangle
- 4**



7 (.28)
Square
- 6**



8 (.32) Hex
recess
- 10**



8 (.32) Square
driver
- 11**



Railway
standard
- 18**



10 (.37)
Hex
- 20**



8 (.32)
Triangle

E3 - 14 H - G F

F Finish

- 1 Chrome plated
- 5 Black powder coated
- 7 Silver powder coated

G Grip			
Total Grip	G	Total Grip	G
19 (.75)	00	39 (1.53)	10
21 (.83)	01	41 (1.61)	11
23 (.91)	02	43 (1.69)	12
25 (.98)	03	45 (1.77)	13
27 (1.06)	04	47 (1.85)	14
29 (1.14)	05	49 (1.93)	15
31 (1.30)	06	51 (2.01)	16
33 (1.30)	07	53 (2.09)	17
35 (1.38)	08	55 (2.17)	18
37 (1.46)	09	57 (2.24)	19



E3 VISE ACTION® Compression Latch

Zinc housing · Tool operated

Visual Indicator of latch status · Fixed or Adjustable grip · 19.1mm size



- Feature indicates when latch is open
- Consistent pre-set compression
- EN 45545-3 E10 Compliant

Material and Finish

Zinc alloy, powder coated or chrome plated and steel, zinc plated

Performance Details

Adjustable Grip: Maximum static load: 450 N (100lbf)

Fixed Grip: Maximum static load: 450 N (100lbf)

Sealing Notes

NEMA 4 / IP65 enabled by using supplied flange gasket

Installation Notes

Recommended tightening torque for the mounting nut is 20 N·m (176 in·lbf).

Adjustable Grip: Position cam so latching function can be achieved comfortably by hand.

Fixed Grip: Mounting screw torque 10 N·m (88 in·lbf)

Keys and Accessories

See pages 118-121

FIXED GRIP

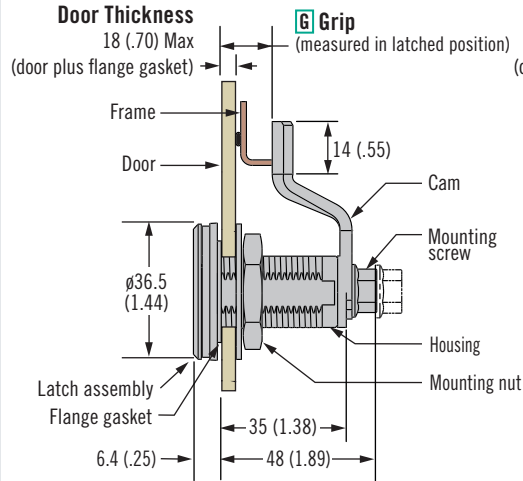

ADJUSTABLE GRIP

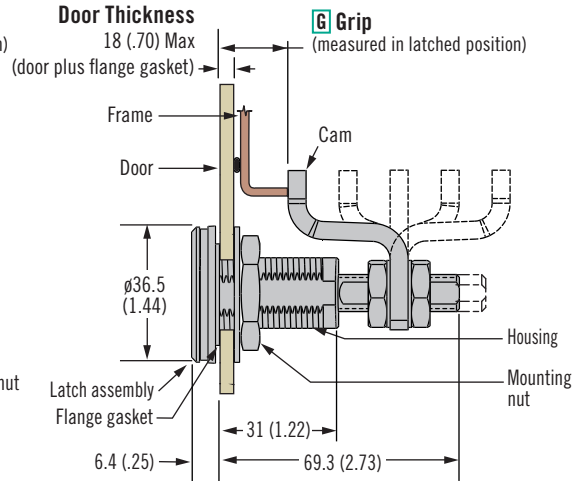

Latch Open

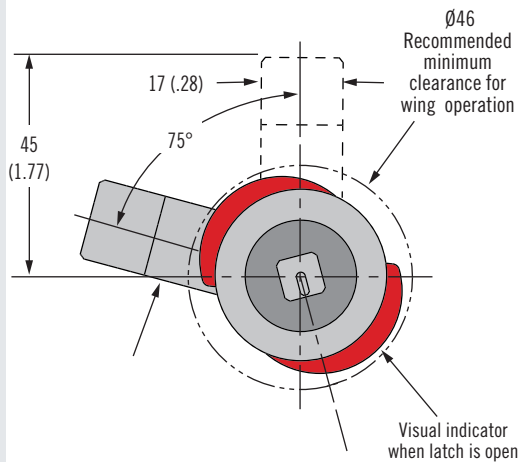

Latch Closed

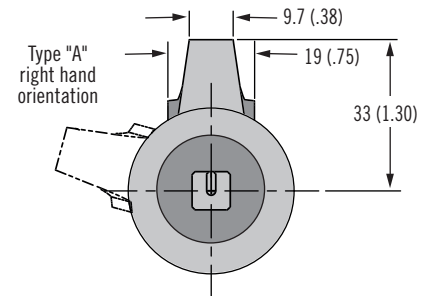

Make Safety Visible™
by Southco

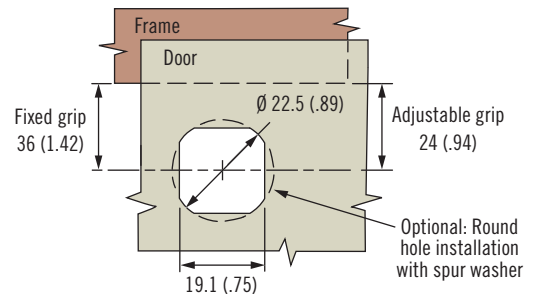
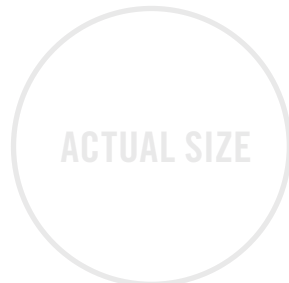

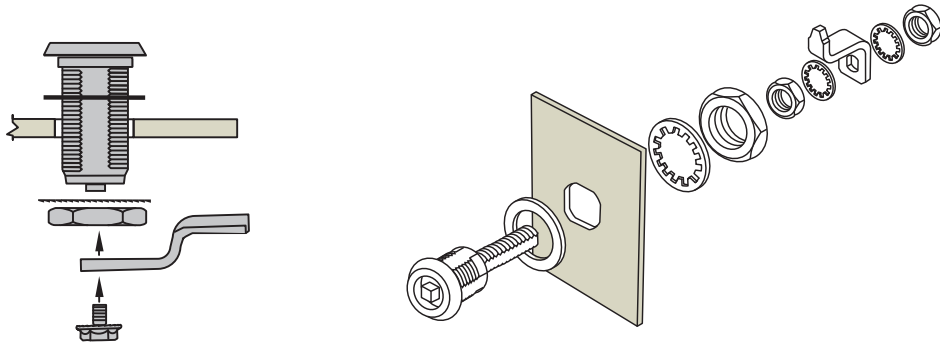

H Head Styles

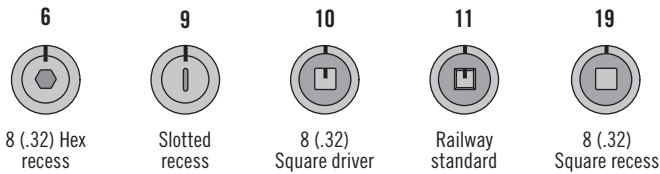

F Finish

- 1 Chrome plated
- 5 Black powder coated
- 7 Silver powder coated

FIXED GRIP

R Rotation

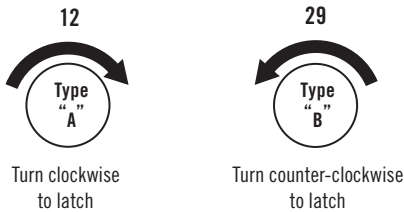

ADJUSTABLE GRIP

R Rotation

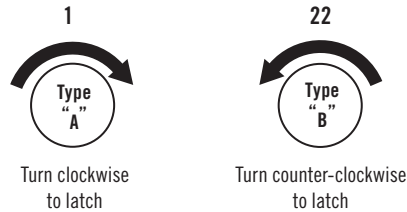

E3 - A R H - UU F

E3 - A R H - O F

Part Number Selection

See table
 Order Latch and Cam separately
 Select grip from Cam table.
 For Fixed Grip, if your grip is
 between two options choose the
 smaller grip

Cam Part Number (order separately from latch)			
Grip	Part Number	Grip	Part Number
15 (.59)	E5-2500	35 (1.38)	E5-2510
17 (.67)	E5-2501	37 (1.46)	E5-2511
19 (.75)	E5-2502	39 (1.53)	E5-2512
21 (.83)	E5-2503	41 (1.61)	E5-2513
23 (.91)	E5-2504	43 (1.69)	E5-2514
25 (.98)	E5-2505	45 (1.77)	E5-2515
27 (1.06)	E5-2506	47 (1.85)	E5-2516
29 (1.14)	E5-2507	49 (1.93)	E5-2517
31 (1.22)	E5-2508	51 (2.01)	E5-2518
33 (1.30)	E5-2509	53 (2.09)	E5-2519

Cam Part Number (order separately from latch)			
Minimum Grip	Maximum Grip	Cam Type	Part Number
11.4 (.45)	27.2 (1.07)	Deep offset cam, forward	E3-28-201-12
66.3 (2.61)	76.2 (3.00)	Deep offset cam, reversed	
25.4 (1.00)	41.1 (1.62)	Offset cam, forward	E3-28-202-12
52.6 (2.07)	68.3 (2.69)	Offset cam, reversed	
38.9 (1.53)	54.6 (2.15)	Straight cam	E3-28-203-12





E3 VISE ACTION® Compression Latch

Stainless steel housing · Tool operated
Fixed or adjustable grip · 19.1mm size



- Consistent pre-set compression
- Premium finish
- Corrosion resistance
- Tool operated for security
- EN 45545-3 E60 Compliant

Material and Finish

Stainless steel 304 and 316

Performance Details

Compression: 6.4 mm (.25 in)

Maximum static load:

Adjustable Grip: 600 N (136 lbf)

Fixed Grip: 450 N (100 lbf)

Sealing Notes

NEMA 4 and IP66/IP67 enabled by using supplied flange gasket

Installation Notes

Recommended tightening torque for the mounting nut is

20 N·m (176 in-lbf)

Adjustable Grip: Position cam so latching function can be achieved comfortably by hand.

Fixed Grip: Mounting screw torque 10 N·m (88 in-lbf)

Keys and Accessories

See pages 118-121

FIXED GRIP

Door thickness

18 (.71), latch unassembled.
(door plus flange gasket)

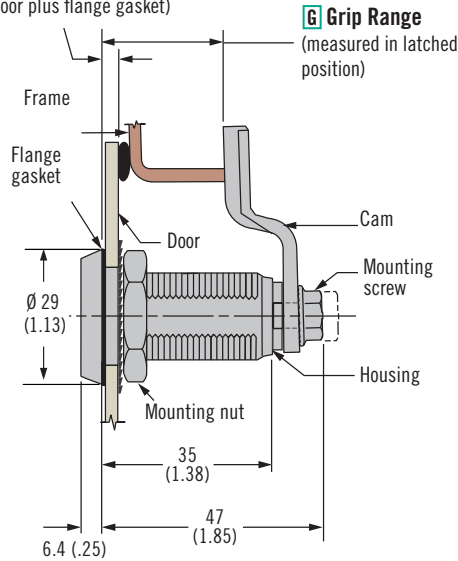

ADJUSTABLE GRIP

Door thickness

18 (.71), latch unassembled.
(door plus flange gasket)

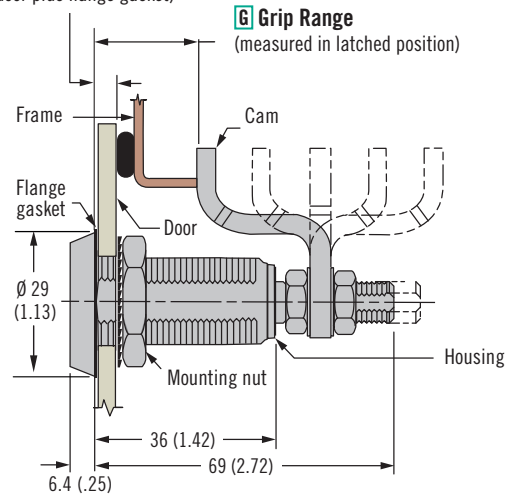

Latch open

Type "A" clockwise to latch

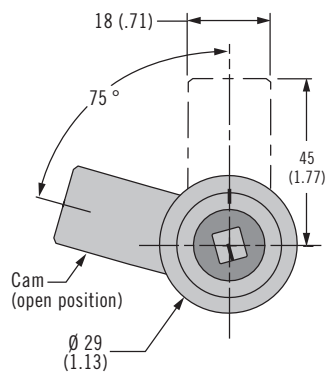

Latch closed

Type "A" clockwise to latch

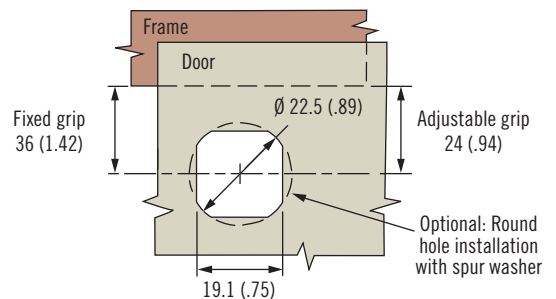
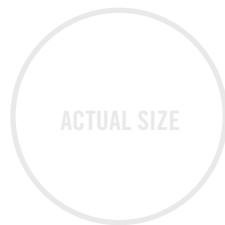
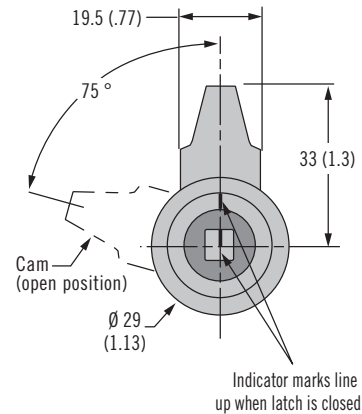

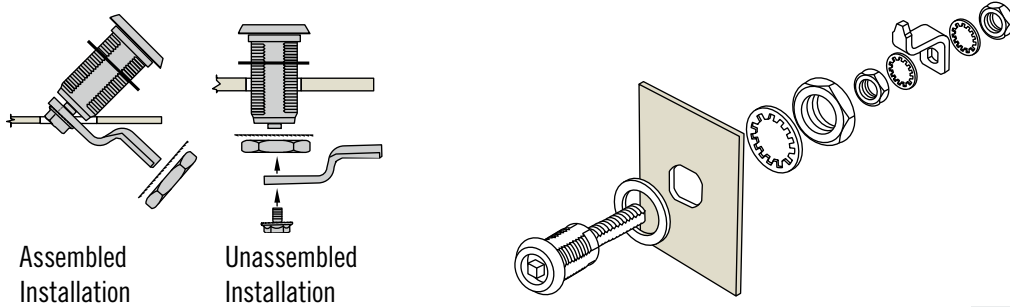

Part Number Selection

E3 - R H - G O

H Head Styles

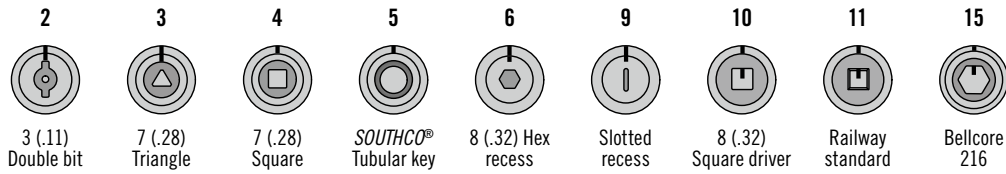

FIXED GRIP

R Rotation

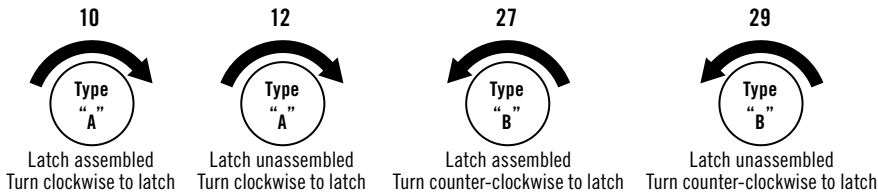

ADJUSTABLE GRIP

R Rotation

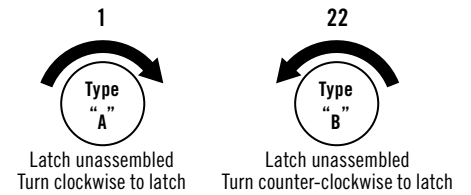

G Grip Table					
Total Grip	G	Max. Door Thickness for Assembled Latch	Total Grip	G	Max. Door Thickness for Assembled Latch
20 (.79)	00	1 (.04)	40 (1.57)	10	7 (.28)
22 (.87)	01	2 (.08)	42 (1.65)	11	
24 (.94)	02	4 (.16)	44 (1.73)	12	
26 (1.02)	03	5 (.20)	46 (1.81)	13	
28 (1.10)	04	6 (.24)	48 (1.89)	14	
30 (1.18)	05	7 (.28)	50 (1.97)	15	
32 (1.26)	06		52 (2.05)	16	
34 (1.34)	07		54 (2.13)	17	
36 (1.42)	08		56 (2.20)	18	
38 (1.50)	09		58 (2.28)	19	

For Fixed Grip, if your grip is between two options choose the smaller grip

G Grip	Minimum	Maximum	Cam Type
1	16.4 (.64)	32.2 (1.26)	Deep offset cam, forward
	71.3 (2.80)	81.2 (3.19)	Deep offset cam, reversed
2	30.4 (1.19)	46.1 (1.81)	Offset cam, forward
	57.6 (2.26)	73.3 (2.88)	Offset cam, reversed
3	43.9 (1.72)	59.6 (2.34)	Straight cam



E3 VISE ACTION® Compression Latch

Stainless steel housing · Tool operated

Compact · Fixed or adjustable grip · 19.1mm size

- Minimal panel intrusion
- Consistent pre-set compression
- Premium finish
- Corrosion resistance
- Tool operated for security
- EN 45545-3 E60 Compliant

Material and Finish

Stainless steel 304 and 316

Performance Details

Compression: 6.4 mm (.25 in)

Maximum static load:

Adjustable Grip: 600 N (136 lbf)

Fixed Grip: 450 N (100 lbf)

Sealing Notes

NEMA 4 and IP65 enabled by using supplied flange gasket

Installation Notes

Recommended tightening torque for the mounting nut is 20 N·m (176 in-lbf)

Adjustable Grip: Position cam so latching function can be achieved comfortably by hand.

Fixed Grip: Mounting screw torque 10 N·m (88 in-lbf)

Keys and Accessories

See pages 118-121

FIXED GRIP

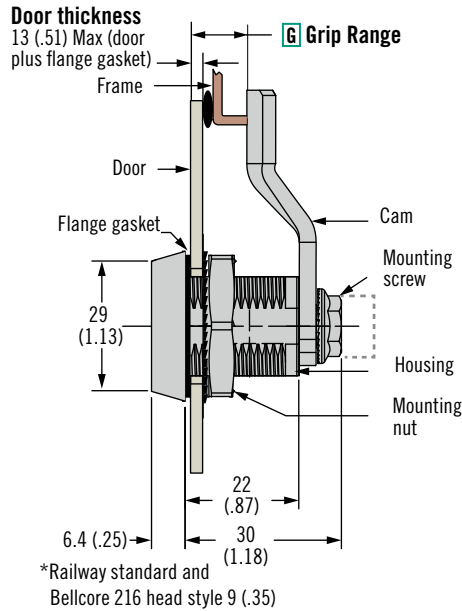

ADJUSTABLE GRIP

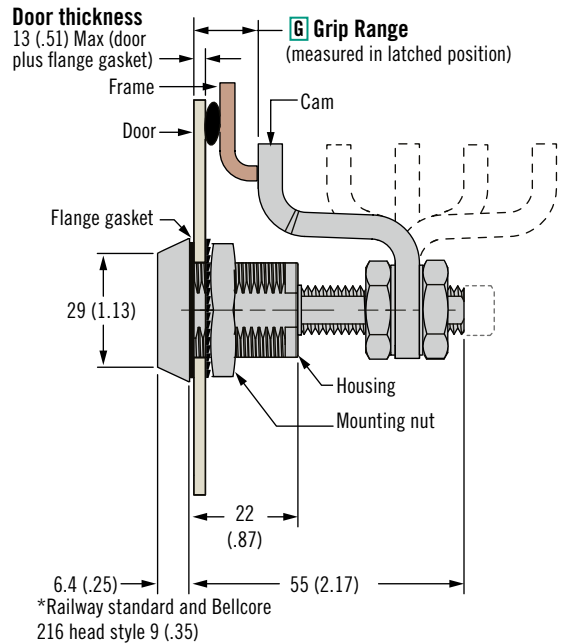

Latch open

Type "A" clockwise to latch

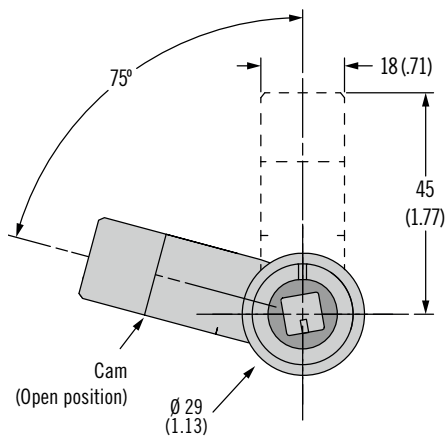

Latch closed

Type "A" clockwise to latch

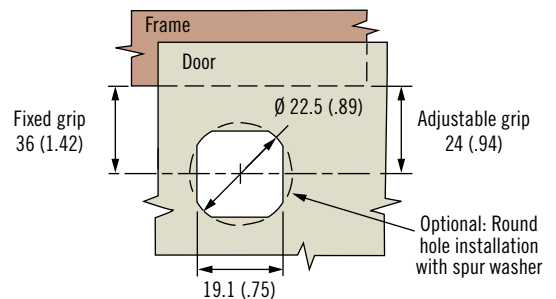
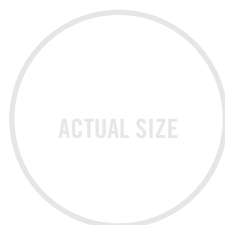
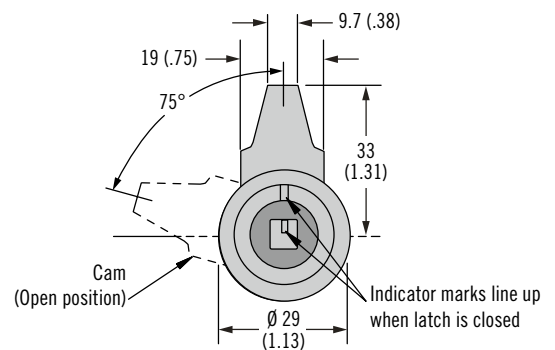

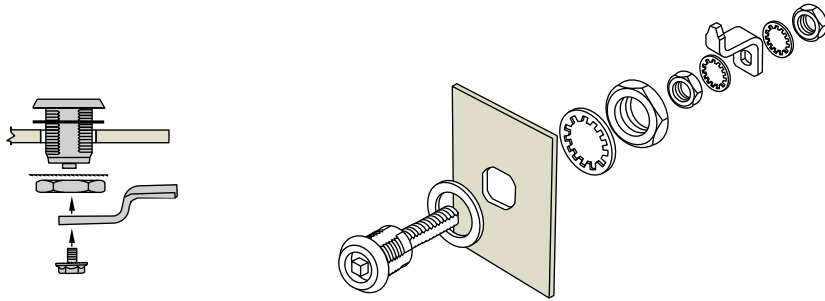

FIXED GRIP

E3 - C R H - UUO

ADJUSTABLE GRIP

E3 - C R H - 00

Part Number Selection

See table
Order latch and cam separately.

H Head Styles

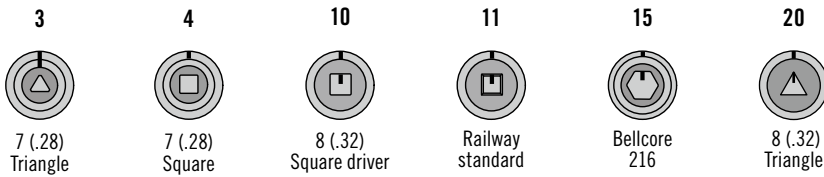

R Rotation

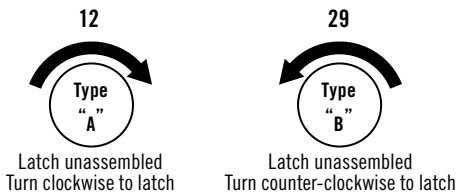

R Rotation

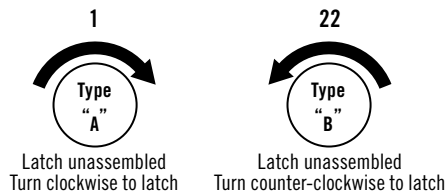

Cam Part Number (order separately from latch)			
Grip	Part Number	Grip	Part Number
4 (.16)	E3-28-700-24	24 (.94)	E3-28-710-24
6 (.24)	E3-28-701-24	26 (1.02)	E3-28-711-24
8 (.31)	E3-28-702-24	28 (1.10)	E3-28-712-24
10 (.39)	E3-28-703-24	30 (1.18)	E3-28-713-24
12 (.47)	E3-28-704-24	32 (1.26)	E3-28-714-24
14 (.55)	E3-28-705-24	34 (1.34)	E3-28-715-24
16 (.63)	E3-28-706-24	36 (1.42)	E3-28-716-24
18 (.71)	E3-28-707-24	38 (1.50)	E3-28-717-24
20 (.79)	E3-28-708-24	40 (1.57)	E3-28-718-24
22 (.87)	E3-28-709-24	42 (1.65)	E3-28-719-24

Cam Part Number Table (order separately from latch)			
Minimum Grip	Maximum Grip	Cam Type	Part Number
3.3 (.13)	14.7 (.58)	Deep offset cam, forward	E3-28-201-24
56.6 (2.23)	66.5 (2.62)	Deep offset cam, reversed	
14.6 (.57)	30.3 (1.19)	Offset cam, forward	E3-28-202-24
42 (1.65)	57.7 (2.27)	Offset cam, reversed	
28.2 (1.13)	44.5 (1.75)	Straight cam	E3-28-203-24

Select grip from Cam table if your grip is between two options choose the smaller grip





E3 VISE ACTION[®] Compression Latch

Stainless steel housing · Tool operated

High-pressure sealed · Fixed or adjustable grip · 19.1mm size

- Consistent pre-set compression
- Premium finish
- Corrosion resistance
- IP69K Compliant
- Easy clean
- Conform to DIN EN 1672-2
- Tool operated for security
- EN 45545-3 E60 Compliant

Material and Finish

Stainless Steel 316

Performance Details

Compression: 6.4 mm (.25 in)

Maximum static load:

Adjustable Grip: 600 N (136 lbf)

Fixed Grip: 450 N (100 lbf)

Keys

Use Southco key E3-17-1 only

Installation Notes

Recommended tightening torque for the mounting nut is

20 N·m (176 in·lbf)

Accessories

Replacement flange gasket:

Part number: E5-17-101

FIXED GRIP

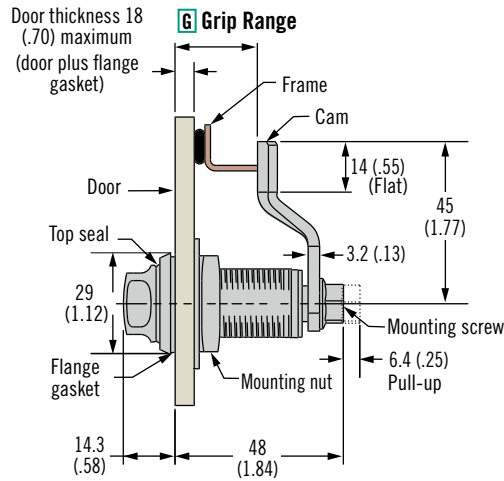

ADJUSTABLE GRIP

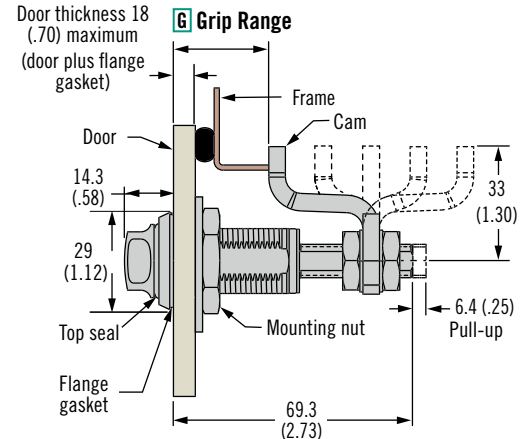

Latch Open

Type "A" clockwise to latch

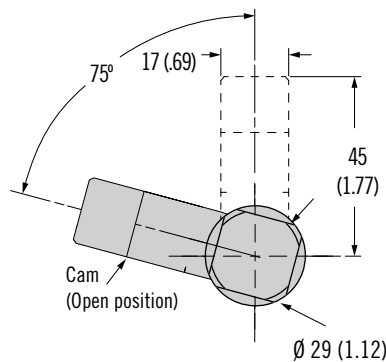

Latch Closed

Type "A" clockwise to latch

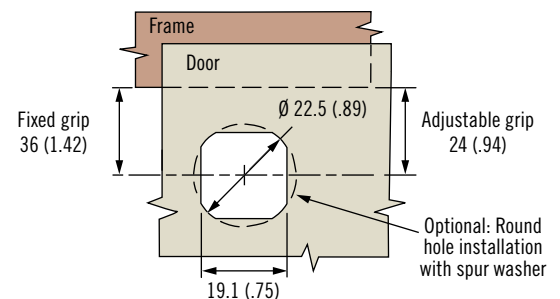
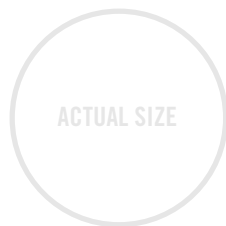
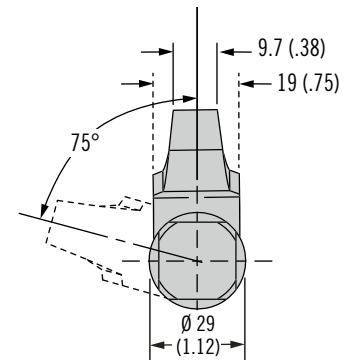

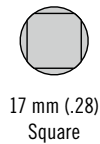
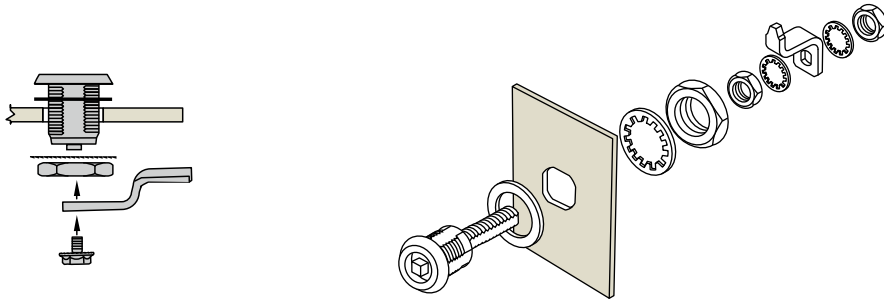

Part Number Selection

FIXED GRIP

E3 - H R 38 - UUO

R Rotation

12

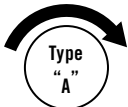

Latch unassembled
Turn clockwise to latch

29

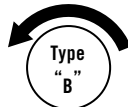

Latch unassembled
Turn counter-clockwise to latch

ADJUSTABLE GRIP

E3 - H R 38 - 00

R Rotation

1



Latch unassembled
Turn clockwise to latch

22

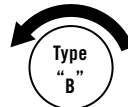

Latch unassembled
Turn counter-clockwise to latch

Fixed Grip Cam part number

Grip	Part Number	Grip	Part Number
20 (.79)	E5-1200-24	40 (1.57)	E5-1210-24
22 (.87)	E5-1201-24	42 (1.65)	E5-1211-24
24 (.94)	E5-1202-24	44 (1.73)	E5-1212-24
26 (1.02)	E5-1203-24	46 (1.81)	E5-1213-24
28 (1.10)	E5-1204-24	48 (1.89)	E5-1214-24
30 (1.18)	E5-1205-24	50 (1.97)	E5-1215-24
32 (1.26)	E5-1206-24	52 (2.05)	E5-1216-24
34 (1.34)	E5-1207-24	54 (2.13)	E5-1217-24
36 (1.42)	E5-1208-24	56 (2.20)	E5-1218-24
38 (1.50)	E5-1209-24	58 (2.28)	E5-1219-24

Adjustable Grip Cam part number

Minimum Grip	Maximum Grip	Cam Type	Part Number
16.4 (.64)	32.2 (1.26)	Deep offset cam, forward	E3-28-201-24
71.3 (2.80)	81.2 (3.19)	Deep offset cam, reversed	
30.4 (1.19)	46.1 (1.81)	Offset cam, forward	E3-28-202-24
57.6 (2.26)	73.3 (2.88)	Offset cam, reversed	
43.9 (1.72)	59.6 (2.34)	Straight cam	E3-28-203-24

See table
Order latch and cam separately.
Select grip from Cam table if your grip is between two options choose the smaller grip



E3 VISE ACTION® Compression Latch

Stainless steel housing · Tool operated

Bi-Stable cover series · Fixed or adjustable grip · 19.1mm size

- Consistent pre-set compression
- Premium finish
- Corrosion resistance
- Designed to work with separate bi-stable cover with fin
- Cover pops open when latch is not secure, providing visual indication of latch status
- Tool operated for security
- EN 45545-3 E60 Compliant

Material and Finish

Latch: Stainless steel 304 and 316

Cover: Stainless steel 316

Performance Details

Compression: 6.4 mm (.25 in)

Maximum static load:

Adjustable Grip: 600 N (136 lbf)

Fixed Grip: 450 N (100 lbf)

Sealing Notes

Latch: NEMA 4 and IP65 enabled by using the supplied flange gasket

Latch with Bi-Stable Cover: NEMA 4 and IP66 enabled by using the supplied flange gasket

Installation Notes

Recommended tightening torque for the mounting nut is 20 N·m (176 in-lbf).

Adjustable Grip: Position cam so latching function can be achieved comfortably by hand.

Fixed Grip: Mounting screw torque 10 N·m (88 in-lbf)

Keys and Accessories

See pages 118-121 (modified head styles work with standard keys)

Make Safety Visible™
by Southco

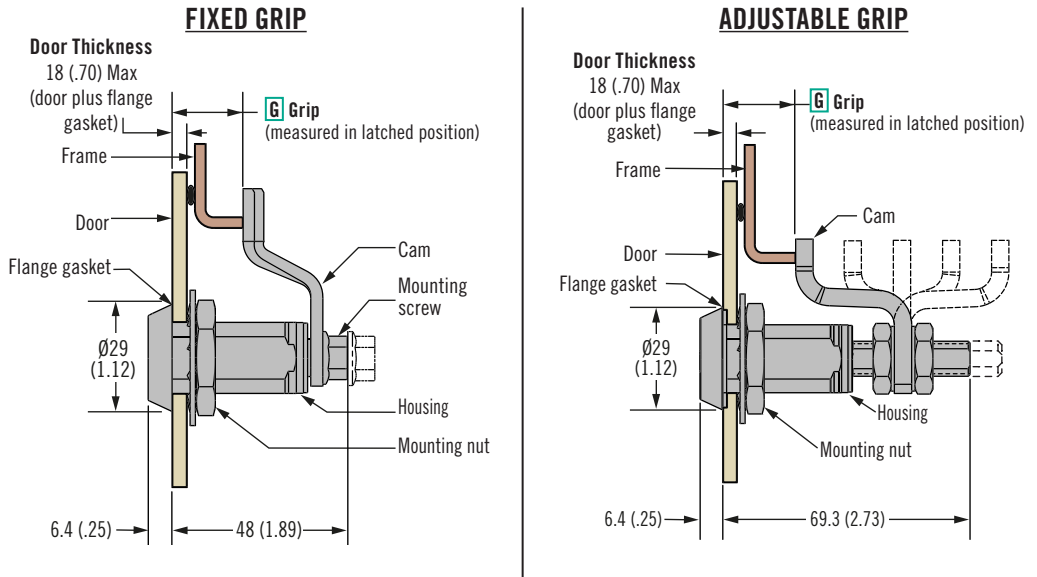

Bi-Stable Cover with fin
Part number E3-80-251-40 (ordered separately)

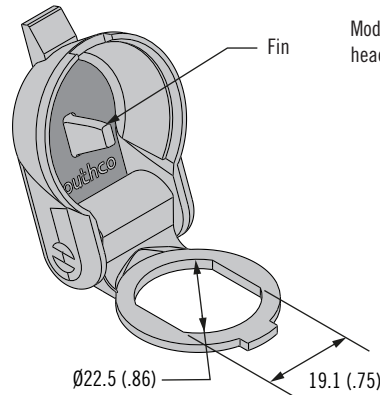

Bi-Stable Cover Latch

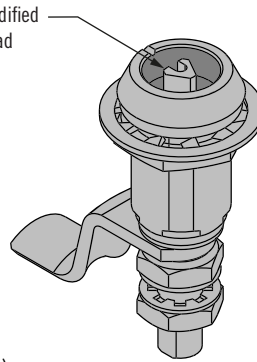

Bi-Stable Cover with fin installed on Bi-Stable Cover Latch

The Bi-Stable Cover can be completely closed only when the latch is fully secured and the fin fits into the notch in the modified head.

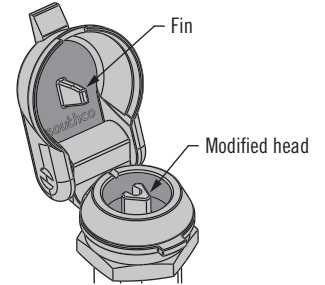

Cover in open position

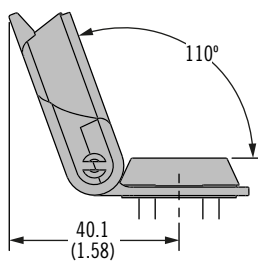

Cover returns to open position

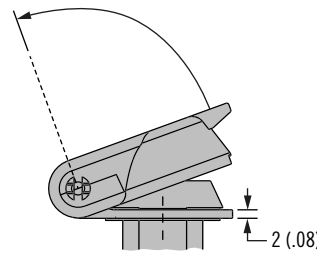

Cover in closed position

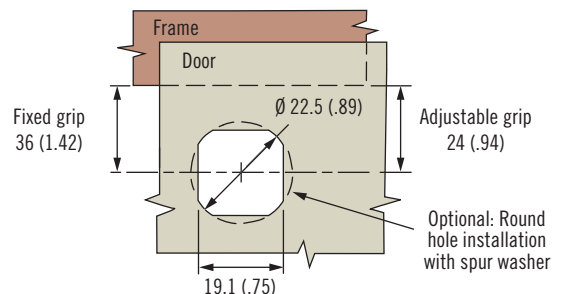
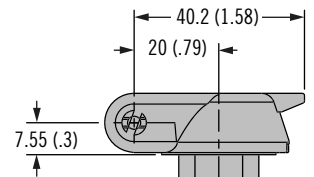

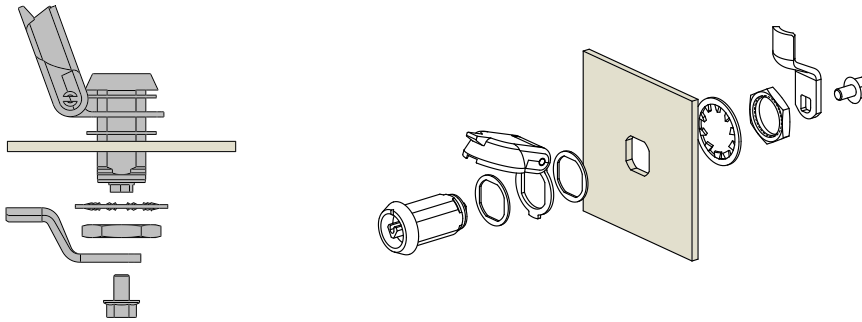

H Head Styles

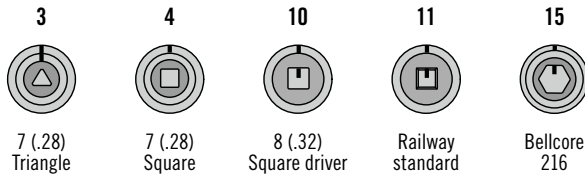

FIXED GRIP

R Rotation

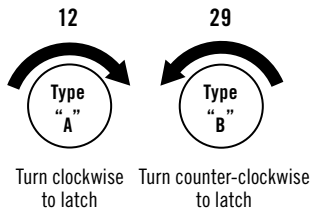

ADJUSTABLE GRIP

R Rotation

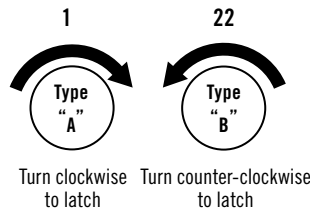

E3 - R H B - UUO

Cam Part Number (order separately from latch)			
Grip	Part Number	Grip	Part Number
20 (.79)	E5-1200-24	40 (1.57)	E5-1210-24
22 (.87)	E5-1201-24	42 (1.65)	E5-1211-24
24 (.94)	E5-1202-24	44 (1.73)	E5-1212-24
26 (1.02)	E5-1203-24	46 (1.81)	E5-1213-24
28 (1.10)	E5-1204-24	48 (1.89)	E5-1214-24
30 (1.18)	E5-1205-24	50 (1.97)	E5-1215-24
32 (1.26)	E5-1206-24	52 (2.05)	E5-1216-24
34 (1.34)	E5-1207-24	54 (2.13)	E5-1217-24
36 (1.42)	E5-1208-24	56 (2.20)	E5-1218-24
38 (1.50)	E5-1209-24	58 (2.28)	E5-1219-24

E3 - R H B - 00

Cam Part Number (order separately from latch)			
Minimum Grip	Maximum Grip	Cam Type	Part Number
16.4 (.64)	32.2 (1.26)	Deep offset cam, forward	E3-28-201-24
71.3 (2.80)	81.2 (3.19)	Deep offset cam, reversed	
30.4 (1.19)	46.1 (1.81)	Offset cam, forward	E3-28-202-24
57.6 (2.26)	73.3 (2.88)	Offset cam, reversed	
43.9 (1.72)	59.6 (2.34)	Straight cam	E3-28-203-24

Part Number Selection

See table
 Order Latch and Cam separately
 Bi-Stable Cover with fin:
 E3-80-251-40
 Select grip from Cam table.
 For Fixed Grip, if your grip is
 between two options choose the
 smaller grip





E3 VISE ACTION® Compression Latch

Stainless steel housing · Hand operated

T-Handle · Fixed or adjustable grip · 19.1mm size

- Consistent pre-set compression
- Premium finish
- Corrosion resistance
- EN 45545-3 E60 Compliant

Material and Finish

Stainless steel

Performance Details

Compression: 6.4 mm (.25 in)

Maximum static load:

Adjustable Grip: 600 N (136 lbf)

Fixed Grip: 450 N (100 lbf)

Sealing Notes

NEMA 4 and IP65 enabled by using supplied flange gasket

Installation Notes

Recommended tightening torque for the mounting nut is 20 N-m (176 in-lbf).

Adjustable Grip: Position cam so latching function can be achieved comfortably by hand.

Fixed Grip: Mounting screw torque 10 N-m (88 in-lbf)

FIXED GRIP

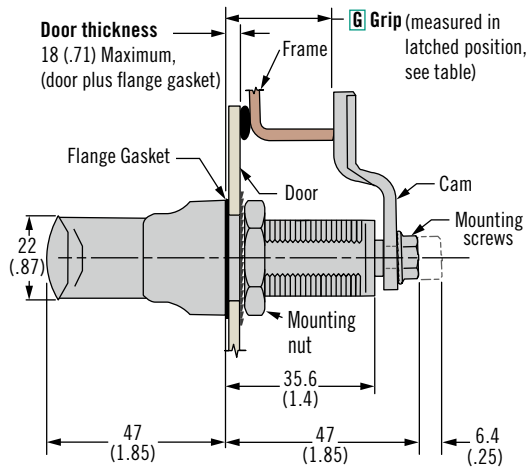

ADJUSTABLE GRIP

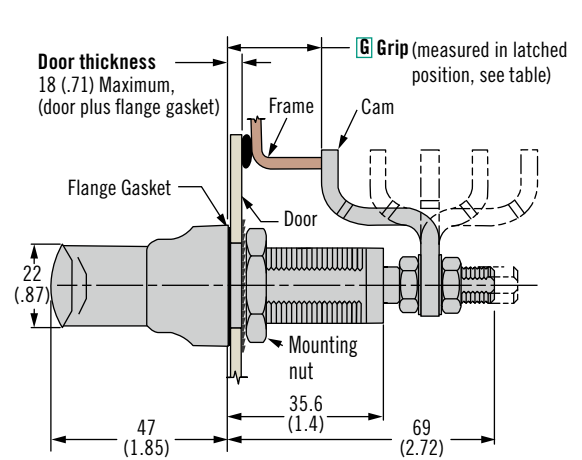

Latch open

Type "A" clockwise to latch

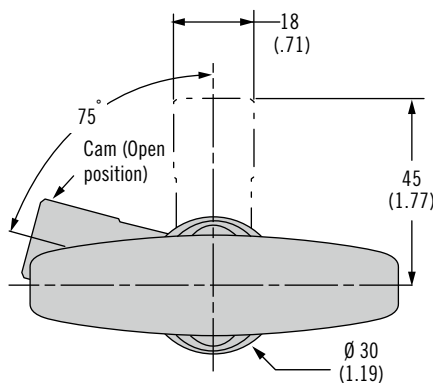

Latch closed

Type "A" clockwise to latch

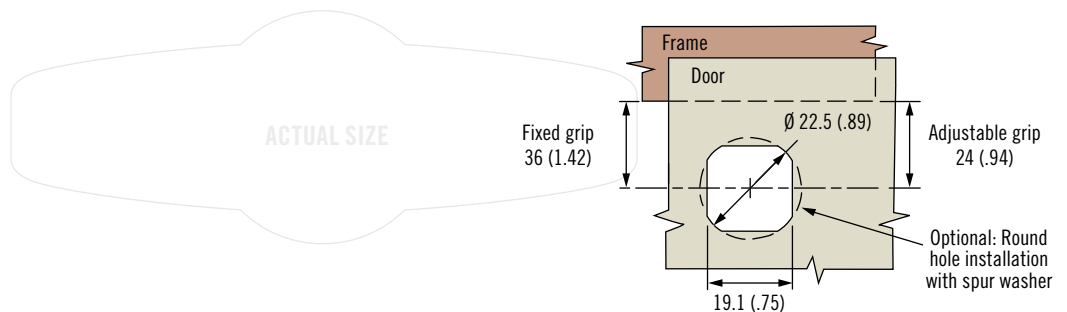
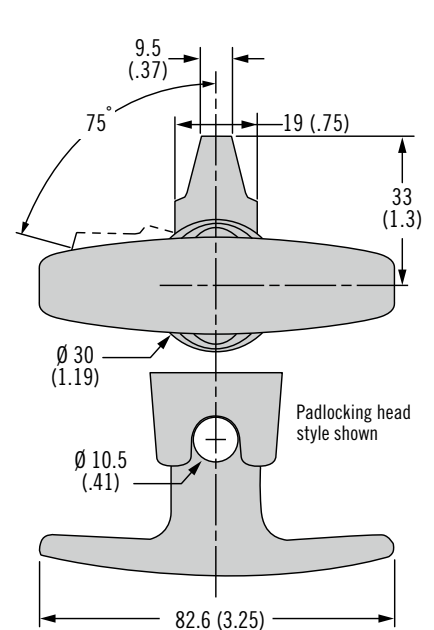

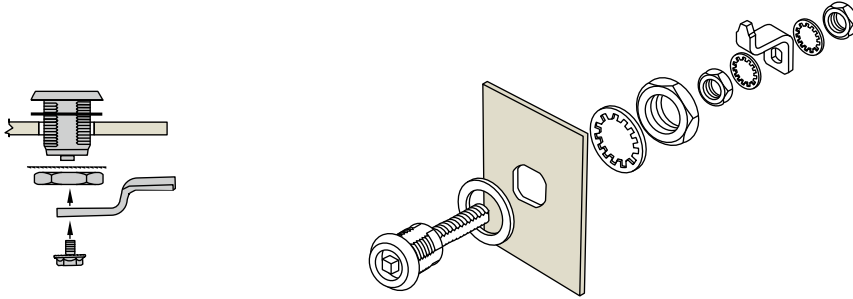

H Head Styles

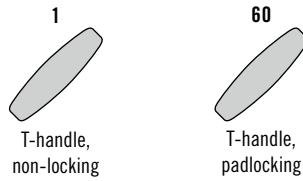

Fixed Grip

E3 - R H - UU12

R Rotation

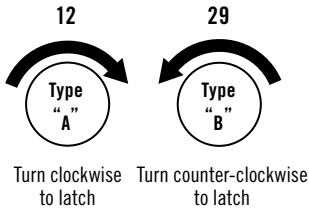

Adjustable Grip

E3 - R H - 012

R Rotation

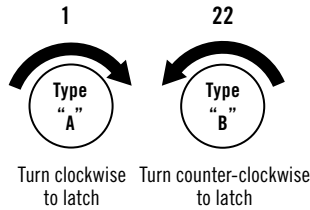

Cam Part Number Table (order separately from latch)

Grip	Part Number	Grip	Part Number
20 (.79)	E5-1200-24	40 (1.57)	E5-1210-24
22 (.87)	E5-1201-24	42 (1.65)	E5-1211-24
24 (.94)	E5-1202-24	44 (1.73)	E5-1212-24
26 (1.02)	E5-1203-24	46 (1.81)	E5-1213-24
28 (1.10)	E5-1204-24	48 (1.89)	E5-1214-24
30 (1.18)	E5-1205-24	50 (1.97)	E5-1215-24
32 (1.26)	E5-1206-24	52 (2.05)	E5-1216-24
34 (1.34)	E5-1207-24	54 (2.13)	E5-1217-24
36 (1.42)	E5-1208-24	56 (2.20)	E5-1218-24
38 (1.50)	E5-1209-24	58 (2.28)	E5-1219-24

Cam Part Number Table (order separately from latch)

Minimum Grip	Maximum Grip	Cam Type	Part Number
16.4 (.64)	32.2 (1.26)	Deep offset cam, forward	E3-28-201-24
71.3 (2.80)	81.2 (3.19)	Deep offset cam, reversed	
30.4 (1.19)	46.1 (1.81)	Offset cam, forward	E3-28-202-24
57.6 (2.26)	73.3 (2.88)	Offset cam, reversed	
43.9 (1.72)	59.6 (2.34)	Straight cam	E3-28-203-24

Part Number Selection



See table
Order latch and cam separately

Select grip from table, if your grip is between two options choose smaller.



E3 VISE ACTION® Compression Latch

Stainless steel housing · Tool or hand operated

Fixed or adjustable grip · 19.1mm size

- Consistent pre-set compression
- Available premium finish
- Corrosion resistance
- Tool operated for security
- EN 45545-3 E60 Compliant

Material and Finish

Stainless steel 304 and 316 (MIM)

Performance Details

Compression: 6.4 mm (.25 in)

Maximum static load:

Adjustable Grip: 556 N (125 lbf)

Fixed Grip: 450 N (100 lbf)

Sealing Notes

NEMA 4 and IP65 enabled by using supplied flange gasket

Installation Notes

Recommended tightening torque for the mounting nut is 20 N·m (176 in·lbf).

Adjustable Grip: Position cam so latching function can be achieved comfortably by hand.

Fixed Grip: Mounting screw torque 10 N·m (88 in·lbf)

Keys and Accessories

See pages 118-121

FIXED GRIP

Door thickness

18 (.70) Max., latch unassembled (door plus flange gasket)

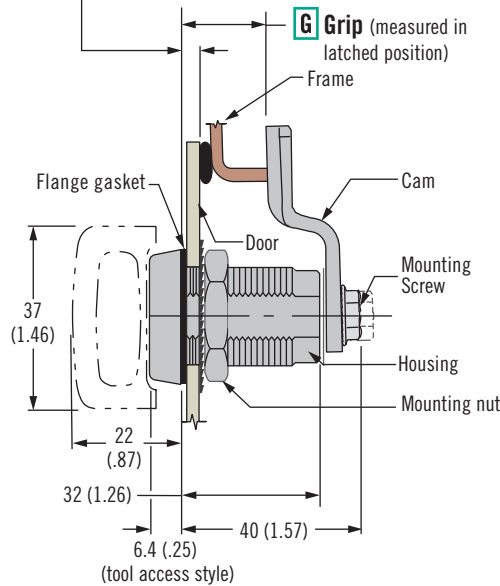

Latch open

Type "A" clockwise to latch

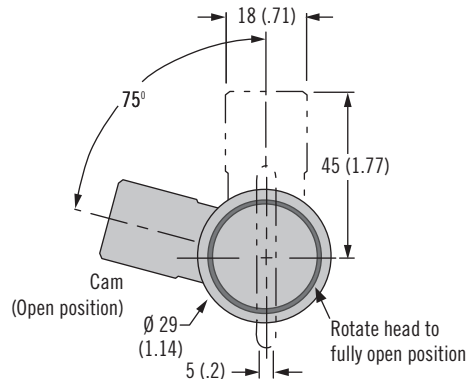

ADJUSTABLE GRIP

Door thickness

18 (.70) Maximum (door plus flange gasket)

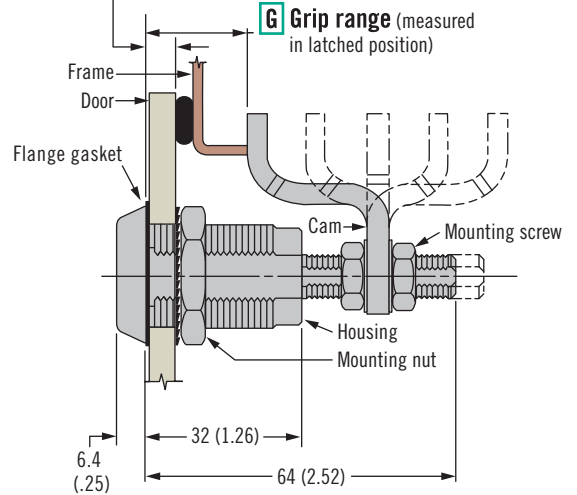

Latch closed

Type "A" clockwise to latch

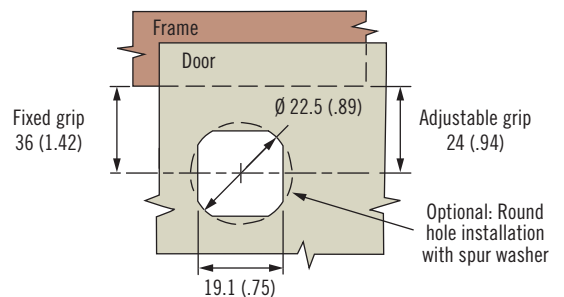
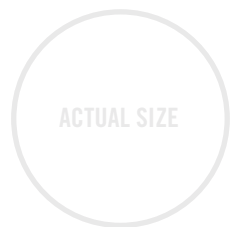
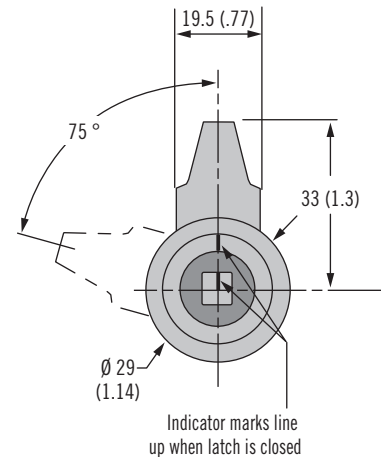

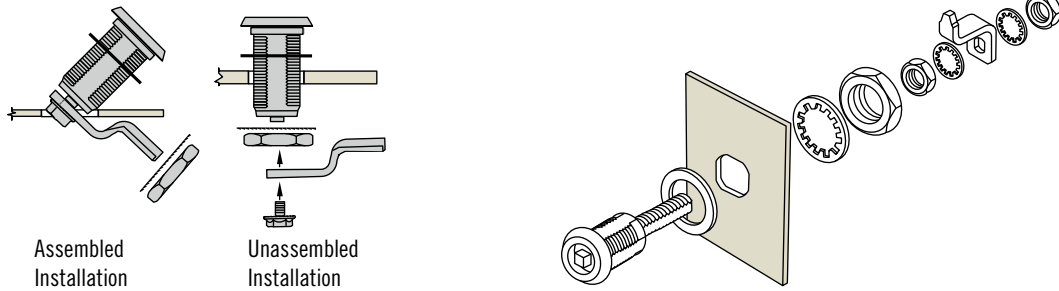

Part Number Selection

E3 - R H - G F

F Finish
 2 Electropolished
 12 Electropolished and hand buffed (bright)

H Head Styles

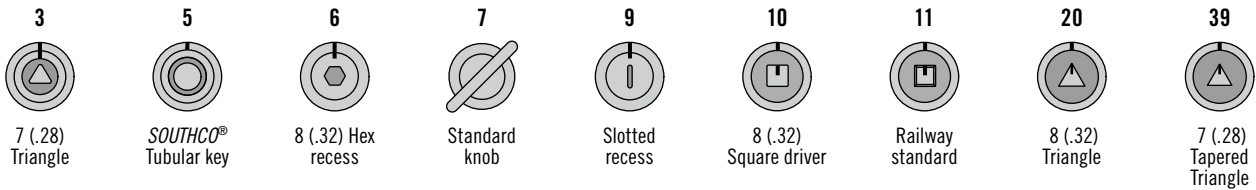

FIXED GRIP

R Rotation

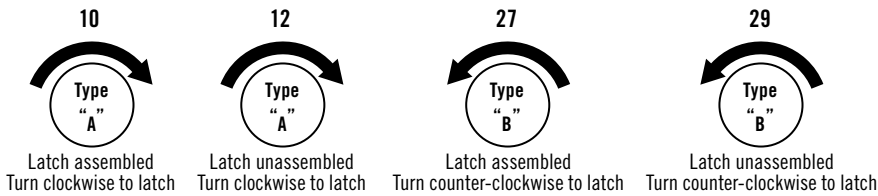

ADJUSTABLE GRIP

R Rotation

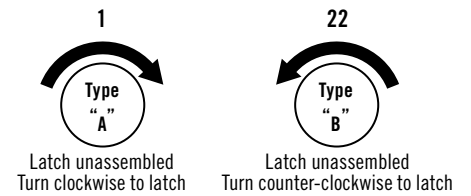

G Grip Table					
Total Grip	G	Max. Door Thickness for Assembled Latch	Total Grip	G	Max. Door Thickness for Assembled Latch
15 (.59)	00	Use unassembled	35 (1.38)	10	7 (.28)
17 (.67)	01	Use unassembled	37 (1.46)	11	
19 (.75)	02	1 (.04)	39 (1.53)	12	
21 (.83)	03	2 (.08)	41 (1.61)	13	
23 (.91)	04	4 (.16)	43 (1.69)	14	
25 (.98)	05	5 (.20)	45 (1.77)	15	
27 (1.06)	06	6 (.24)	47 (1.85)	16	
29 (1.14)	07	7 (.28)	49 (1.93)	17	
31 (1.22)	08		51 (2.01)	18	
33 (1.30)	09		53 (2.09)	19	

For Fixed Grip, if your grip is between two options choose the smaller grip

G Grip	Minimum	Maximum	Cam Type
1	11.4 (.45)	27.2 (1.07)	Deep offset cam, forward
	66.3 (2.61)	76.2 (3.00)	Deep offset cam, reversed
2	25.4 (1.00)	41.1 (1.62)	Offset cam, forward
	52.6 (2.07)	68.3 (2.69)	Offset cam, reversed
3	38.9 (1.53)	54.6 (2.15)	Straight cam



E3 VISE ACTION® Compression Latch

Stainless steel housing · Tool operated
 Compact · Fixed grip · 20.1mm size

- Minimal panel intrusion
- Consistent pre-set compression
- Corrosion resistance
- Tool operated for security
- EN 45545-3 E60 Compliant



Material and Finish

Stainless steel 316 (MIM)

Performance Details

Compression: 6.4 mm (.25 in)
 Maximum static load: 300 N (67 lbf)

Sealing Notes

NEMA 4 and IP65 enabled by using supplied flange gasket

Installation Notes

Recommended tightening torque for the mounting nut is 20 N·m (176 in-lbf)
 Fixed Grip: Mounting screw torque 10 N·m (88 in-lbf)

Keys and Accessories

See pages 118-121

FIXED GRIP

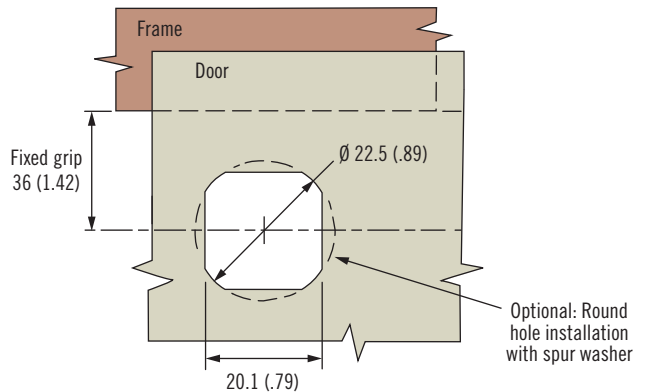
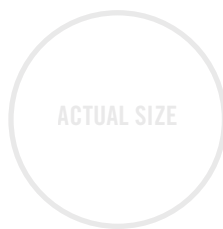
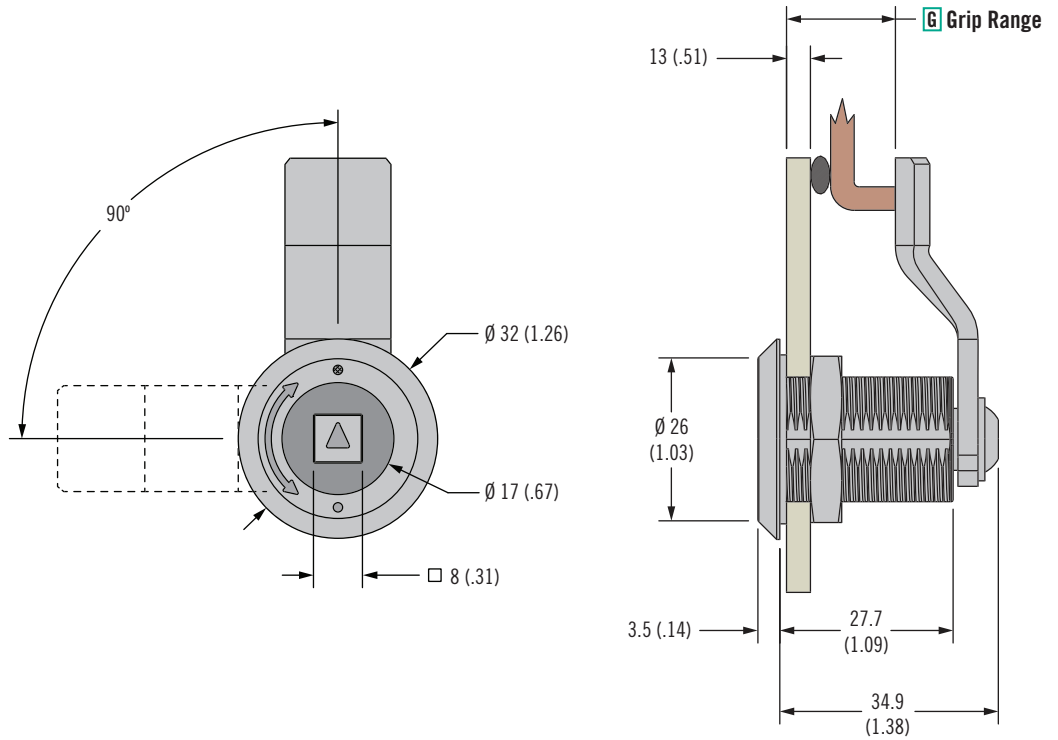

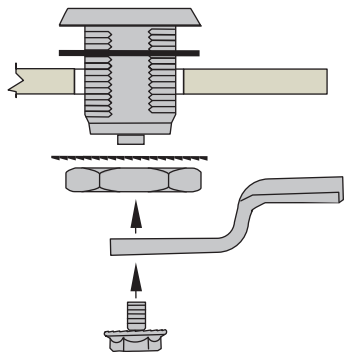

Part Number Selection

See table

Order latch and cam separately.

FIXED GRIP

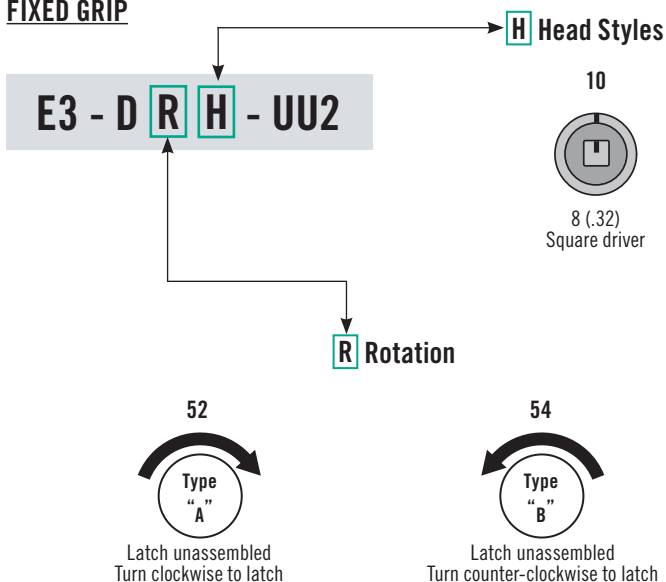

Cam Part Number (order separately from latch)			
Grip	Part Number	Grip	Part Number
10 (.39)	E3-28-700-24	30 (1.18)	E3-28-710-24
12 (.47)	E3-28-701-24	32 (1.26)	E3-28-711-24
14 (.55)	E3-28-702-24	34 (1.34)	E3-28-712-24
16 (.63)	E3-28-703-24	36 (1.42)	E3-28-713-24
18 (.71)	E3-28-704-24	38 (1.50)	E3-28-714-24
20 (.79)	E3-28-705-24	40 (1.57)	E3-28-715-24
22 (.87)	E3-28-706-24	42 (1.65)	E3-28-716-24
24 (.94)	E3-28-707-24	44 (1.73)	E3-28-717-24
26 (1.02)	E3-28-708-24	46 (1.81)	E3-28-718-24
28 (1.10)	E3-28-709-24	48 (1.89)	E3-28-719-24

Select grip from Cam table.

If your grip is between two options choose the smaller grip.



E3 VISE ACTION® Compression Latch

Stainless steel housing · Tool operated

Visual indicator of latch status · Fixed or adjustable grip · 19.1mm size



- Feature indicates when latch is open
- Consistent pre-set compression
- Premium finish
- Corrosion resistance
- Tool operated for security
- EN 45545-3 E60 Compliant

Material and Finish

Stainless steel 304 and 316 (MIM)

Performance Details

Compression: 6.4 mm (.25 in)

Adjustable Grip: Maximum static load: 450 N (100 lbf)

Fixed Grip: Maximum static load: 450 N (100 lbf)

Fixed Grip: Maximum static load: 450 N (100 lbf)

Sealing Notes

NEMA 4 and IP66/IP67 enabled by using supplied flange gasket

Installation Notes

Recommended tightening torque for the mounting nut is 20 N·m (176 in·lbf).

Adjustable Grip: Position cam so latching function can be achieved comfortably by hand.

Fixed Grip: Mounting screw torque 10 Nm (88 in lbf)

Keys and Accessories

See pages 118-121

FIXED GRIP

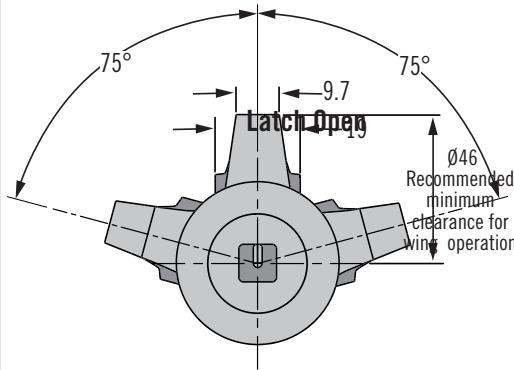
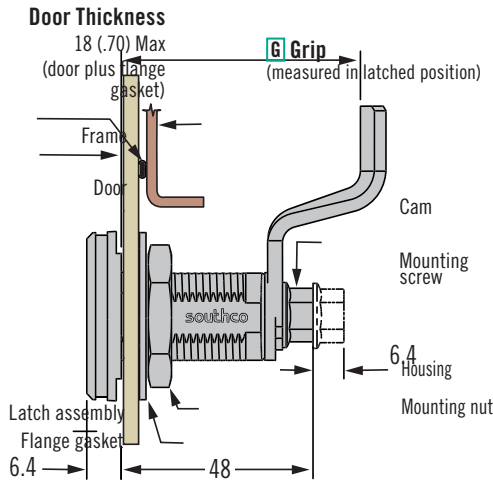

Cam (Open position)

Visual indicator when latch is open

ADJUSTABLE GRIP

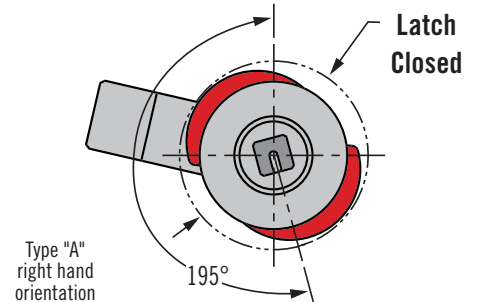
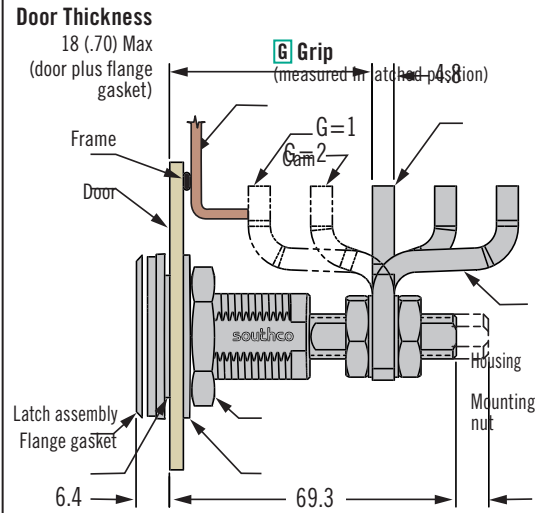

Make Safety Visible™
by Southco

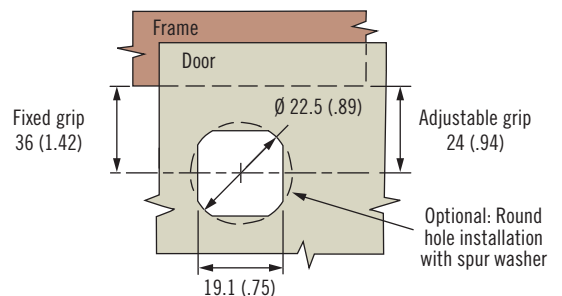

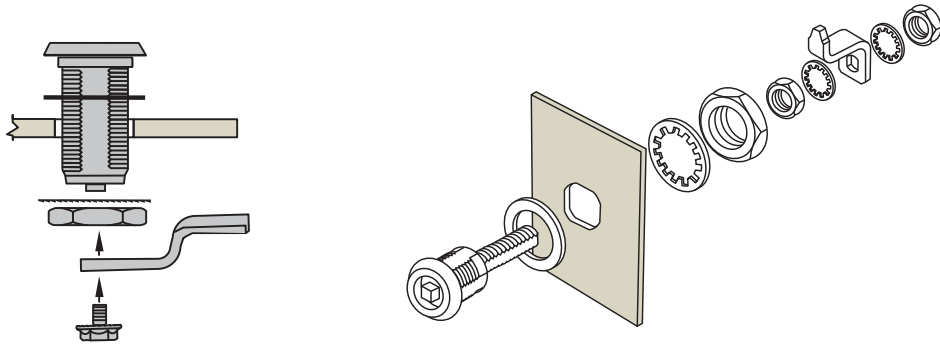

H Head Styles

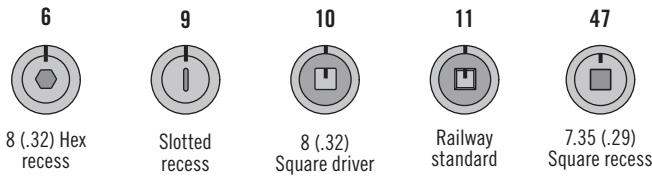

FIXED GRIP

R Rotation

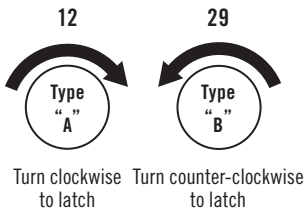

ADJUSTABLE GRIP

R Rotation

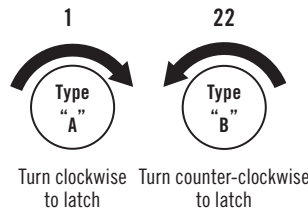

E3 - A R H - UU2

E3 - A R H - 02

Cam Part Number (order separately from latch)			
Grip	Part Number	Grip	Part Number
15 (.59)	E3-28-700-24	35 (1.38)	E3-28-710-24
17 (.67)	E3-28-701-24	37 (1.46)	E3-28-711-24
19 (.75)	E3-28-702-24	39 (1.53)	E3-28-712-24
21 (.83)	E3-28-703-24	41 (1.61)	E3-28-713-24
23 (.91)	E3-28-704-24	43 (1.69)	E3-28-714-24
25 (.98)	E3-28-705-24	45 (1.77)	E3-28-715-24
27 (1.06)	E3-28-706-24	47 (1.85)	E3-28-716-24
29 (1.14)	E3-28-707-24	49 (1.93)	E3-28-717-24
31 (1.22)	E3-28-708-24	51 (2.01)	E3-28-718-24
33 (1.30)	E3-28-709-24	53 (2.09)	E3-28-719-24

Cam Part Number (order separately from latch)			
Minimum Grip	Maximum Grip	Cam Type	Part Number
11.4 (.45)	27.2 (1.07)	Deep offset cam, forward	E3-28-201-24
66.3 (2.61)	76.2 (3.00)	Deep offset cam, reversed	
25.4 (1.00)	41.1 (1.62)	Offset cam, forward	E3-28-202-24
52.6 (2.07)	68.3 (2.69)	Offset cam, reversed	
38.9 (1.53)	54.6 (2.15)	Straight cam	E3-28-203-24

Part Number Selection

See table
 Order Latch and Cam separately
 Select grip from Cam table.
 For Fixed Grip, if your grip is between two options choose the smaller grip





E3 VISE ACTION® Compression Latch

Aluminum housing · Tool operated
Fixed or adjustable grip · 19.1mm size

- Light weight
- Consistent pre-set compression
- Premium finish
- Corrosion resistance
- Tool operated for security
- EN 45545-3 E30 Compliant

Material and Finish

Aluminum, anodized or powder coated
Black hard anodized assembly -
Stainless Steel cam and hardware
All other finishes - Steel cam and hardware

Performance Details

Compression: 6.4 mm (.25 in)
Maximum static load: 530 N (120 lbf)
Complies with DIN EN 61373
vibration standard

Sealing Notes

NEMA 4 and IP65 enabled by using
supplied flange gasket

Installation Notes

Recommended tightening torque for
the mounting nut is
20 N m (176 in lbf).
Position cam so latching function
can be achieved comfortably by
hand.

Keys and Accessories

See pages 118-121

Part Number Selection

See table.

FIXED GRIP

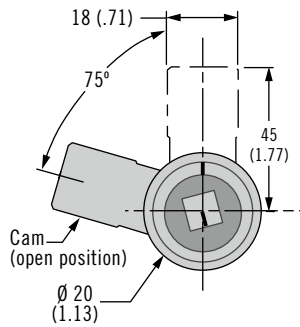
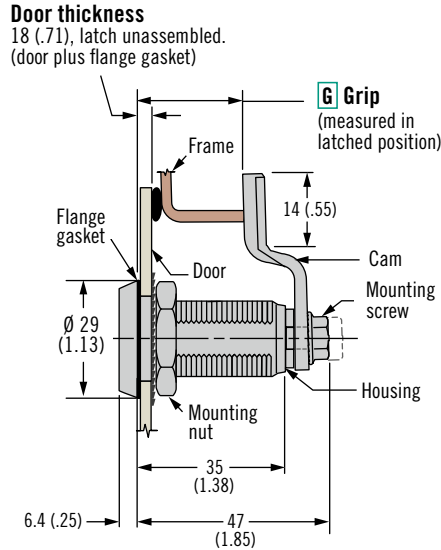

ADJUSTABLE GRIP

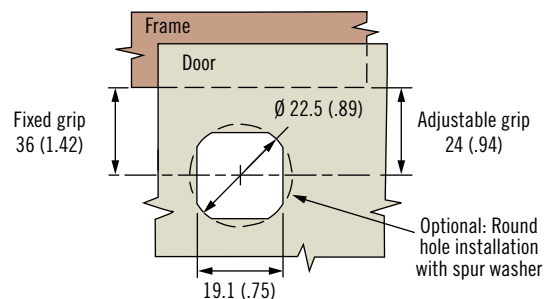
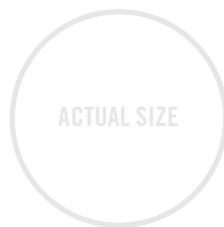
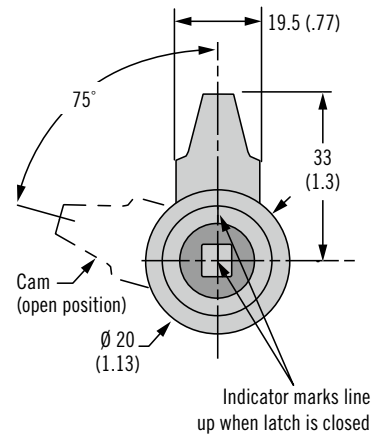
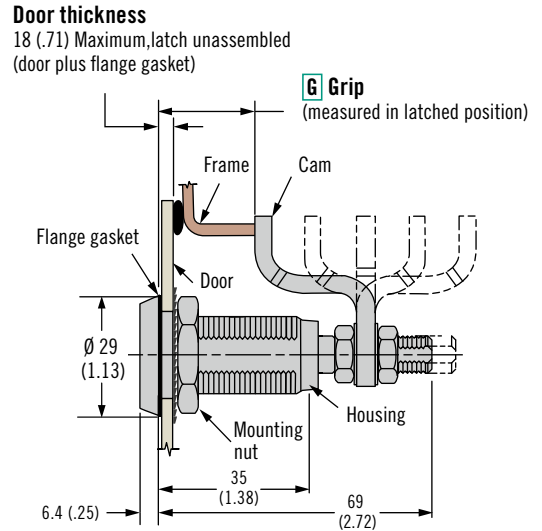

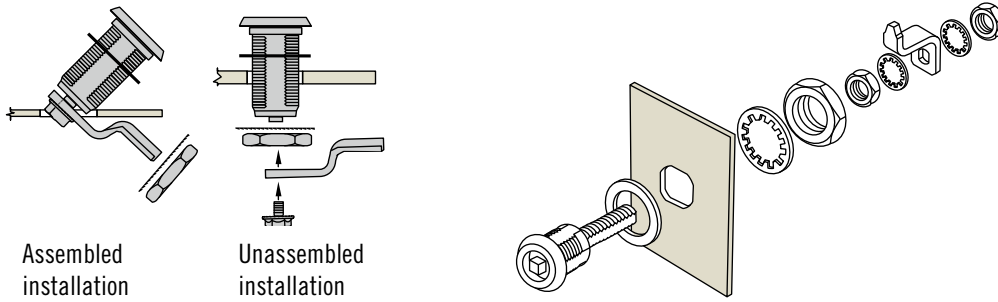

Part Number Selection

E3 - R H - G F

- F Finish**
 59 Black Hard Anodized
 06 Clear Powder Coat
 56 Black Powder Coat
 76 Silver Powder Coat

H Head Styles

- 3**



7 (.28)
Triangle
- 4**



7 (.28)
Square
- 6**



8 (.32) Hex
recess
- 9**



Slotted
recess
- 10**



8 (.32)
Square driver
- 11**



Railway
standard
- 15**



Bellcore
216

FIXED GRIP

ADJUSTABLE GRIP

R Rotation

R Rotation

- 10**



Type "A"
Latch assembled
Turn clockwise to latch
- 12**



Type "A"
Latch unassembled
Turn clockwise to latch
- 27**

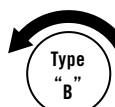

Type "B"
Latch assembled
Turn counter-clockwise to latch
- 29**

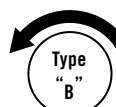

Type "B"
Latch unassembled
Turn counter-clockwise to latch

- 1**



Type "A"
Latch unassembled
Turn clockwise to latch
- 22**

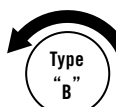

Type "B"
Latch unassembled
Turn counter-clockwise to latch

G Grip Table					
Total Grip	G	Max. Door Thickness for Assembled Latch	Total Grip	G	Max. Door Thickness for Assembled Latch
20 (.79)	00	1 (.04)	40 (1.57)	10	7 (.28)
22 (.87)	01	2 (.08)	42 (1.65)	11	
24 (.94)	02	4 (.16)	44 (1.73)	12	
26 (1.02)	03	5 (.20)	46 (1.81)	13	
28 (1.10)	04	6 (.24)	48 (1.89)	14	
30 (1.18)	05	7 (.28)	50 (1.97)	15	
32 (1.25)	06		52 (2.05)	16	
34 (1.34)	07		54 (2.13)	17	
36 (1.42)	08		56 (2.20)	18	
38 (1.50)	09		58 (2.28)	19	

For Fixed Grip, if your grip is between two options choose the smaller grip

G Grip	Minimum	Maximum	Cam Type
1	16.4 (.64)	32.2 (1.26)	Deep offset cam, forward
	71.3 (2.80)	81.2 (3.19)	Deep offset cam, reversed
2	30.4 (1.19)	46.1 (1.81)	Offset cam, forward
	57.6 (2.26)	73.3 (2.88)	Offset cam, reversed
3	43.9 (1.72)	59.6 (2.34)	Straight cam



E3 VISE ACTION® Compression Latch

Stainless steel housing · Tool or hand operated

Adjustable grip · 13.5mm size

- Reduced dimensions
- Consistent pre-set compression
- Easy grip
- Corrosion resistance
- Tool operated for security
- EN 45545-3 E60 Compliant

Material and Finish

Stainless steel 304 and 316 (MIM)

Performance Details

Compression: 4.3 mm (.17 in)

Maximum static load: 356 N (80 lbf)

Sealing Notes

NEMA 4 and IP65 enabled by using supplied flange gasket

Installation Notes

Recommended tightening torque for the mounting nut is 20 N·m (176 in-lbf).

Position cam so latching function can be achieved comfortably by hand.

Keys & Accessories

See pages 118-121

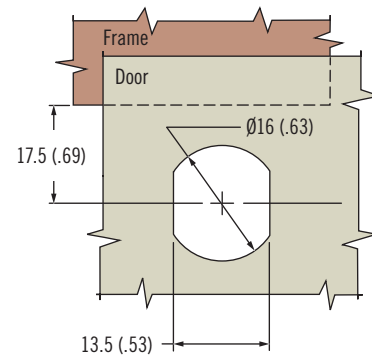
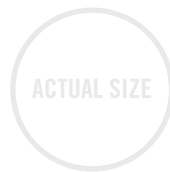
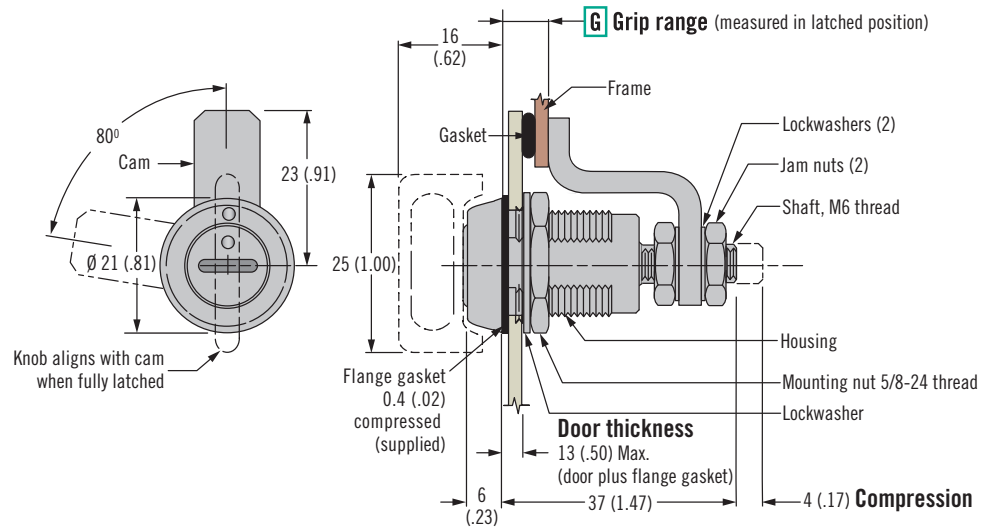

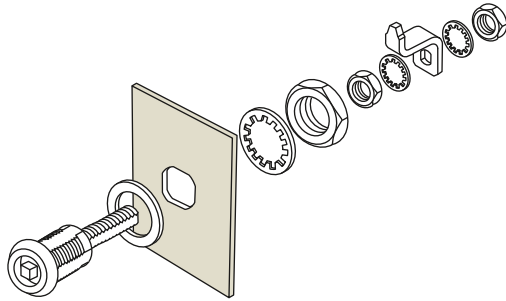

E3 - R H - G F

F Finish
2 Electropolished

H Head Styles

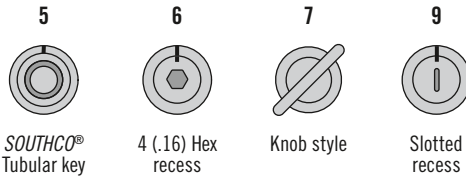

R Rotation

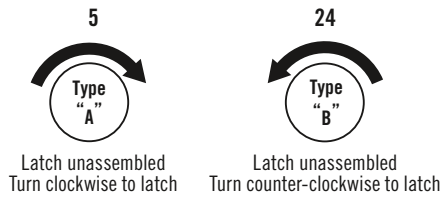

G Grip	Minimum	Maximum
1	3.2 (.13)	6.4 (.25)
2	6.4 (.25)	9.5 (.37)
3	9.5 (.37)	12.7 (.50)
4	12.7 (.50)	15.9 (.63)
5	15.9 (.63)	19 (.75)
6	19 (.75)	22.2 (.87)
7	22.2 (.87)	25.4 (1)
8	25.4 (1)	28.6 (1.13)

Part Number Selection
See table





E3 VISE ACTION® Compression Latch Accessories

Fixed mounting bracket · Flush cup

Material and Finish

Stainless steel or galvanized steel with rubber o-ring

Sealing Notes

Environmental sealing is achieved by using latch with flange gasket and sealing the mounting screw threads.

Notes

For use with 19.1mm size single hole mount tool operated E3 VISE ACTION® compression latches

Flush Mounting Bracket

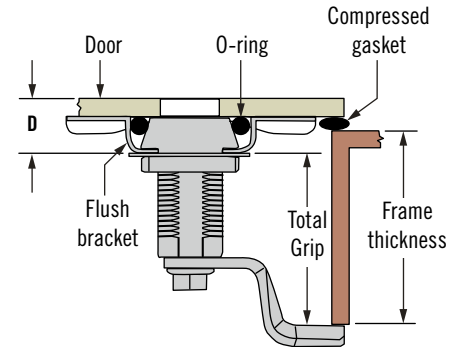
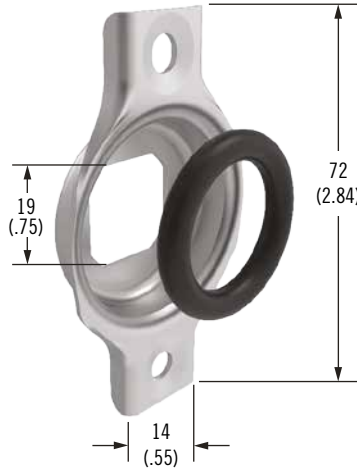

To calculate the **Total Grip**, subtract cup depth (**D**) from **frame thickness + compressed gasket**

E3 - 77 - 25 D - M

D Depth

- 1 6.6 mm (for tool head style)
- 2 9.3 mm (for Railway standard or Bellcore 216 head style only)

M Material

- 12 Galvanized steel
- 24 Stainless steel 304

Material and Finish

Carbon steel, black powder coated

Flush Cup

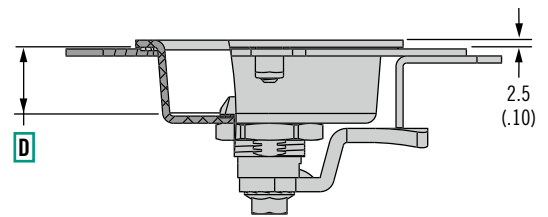
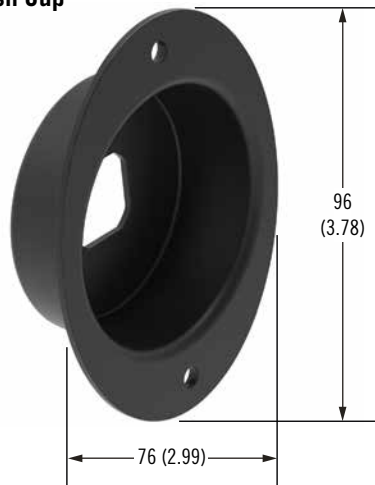

To calculate total grip, add cup depth (**D**) to latch grip

E5 - 2 M - 61 D - 5

M Mounting Style

- 0 M5 studs
- 1 Through hole

D Depth

- 1 19 mm (for wingknob head style)
- 2 4 mm (for tool head style)

E3 VISE ACTION® Compression Latch Accessories

Flange gaskets · Spur washers · Sealing covers



Flange gasket

13.5mm size

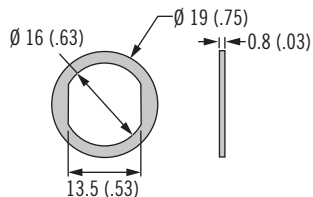

19.1mm size

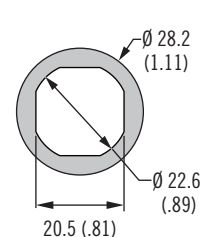

Spur Washer

19.1mm size

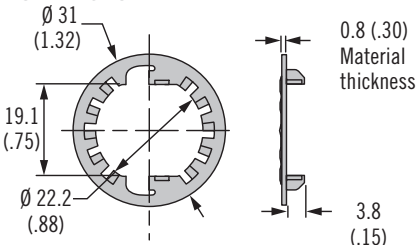

Type	Part Number
Flange gasket 13.5mm size	E3-0-30268-02
Flange gasket 19.1mm size	E5-17
Flange gasket 19.1mm size	E5-17-101

Type	Part Number
Spur washer 19.1mm size	90-6-875

Material and Finish

Flange gasket: Neoprene, natural
Spur washer: Steel, zinc plated

Notes

Spur washer provides for round hole installation in wood and similar materials of low density

Adjustment Formula

Flange gasket : add 0.4 (.02) to door thickness

Spur washer : add 0.8 (.03) to door thickness

Sealing Cover

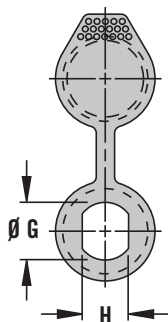
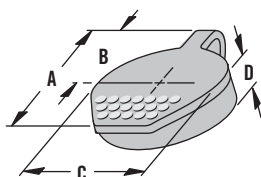

Latch Installation Hole Size		Dimensions			
Ø G	F	A	B	Ø C	D
16 (.63)	13.5 (.53)	40 (1.58)	20 (.85)	29 (1.13)	10.5 (.42)
22.5 (.88)	19.6 (.77)	47 (1.84)	28 (1.09)	35 (1.38)	11.7 (.46)

Type	Part Number
Sealing cover 13.5mm size	90-1
Sealing cover 19.1mm size	90-3

Material and Finish

Sealing cover: Thermoplastic elastomer, black

Notes

Thermoplastic sealing cover cannot be used with Railway standard or Bellcore 216 styles

Adjustment Formula

Sealing cover : add 2.3 (.09) to door thickness

Bi-Stable Sealing Cover – Stainless Steel



Cover in open position

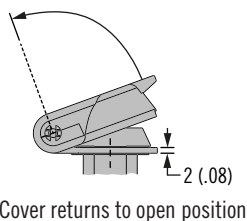
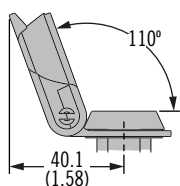

Cover in closed position

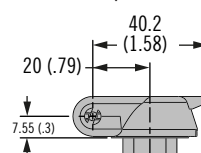

Type	Part Number
Bi-Stable sealing cover 19.1mm size	E3-80-252-40

Material and Finish

Sealing cover: Stainless steel (MIM), electropolished

Notes

Bi-Stable sealing cover can only be used with tool head styles

Adjustment Formula

Sealing cover : add 2.0 (.08) to door thickness



E3 VISE ACTION® Compression Latch Accessories

Padlock brackets · Pull tabs · Sleeve nuts

Material and Finish

Stainless steel, black powder coated

Sealing Notes

To provide sealing use two flange gaskets and add compressed thickness of each flange gasket and bracket thickness to your door thickness.

Notes

Padlock bracket: For 19.1mm size single hole mount tool operated only
Only unassembled styles can be used with round padlock bracket.
Not for use with Southco Tubular Key

Notes

Add 2.0 (.08) to door thickness

Material and Finish

Nylon, black

Adjustment Formula

Add 2.0 (.08) to door thickness

Padlock Bracket (Square)

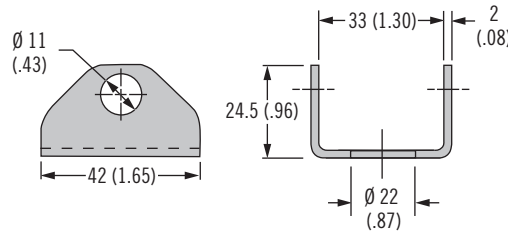

Padlock Bracket (Round)

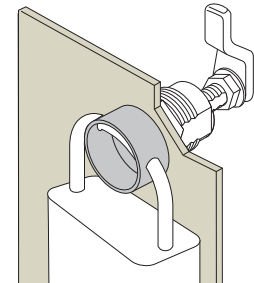
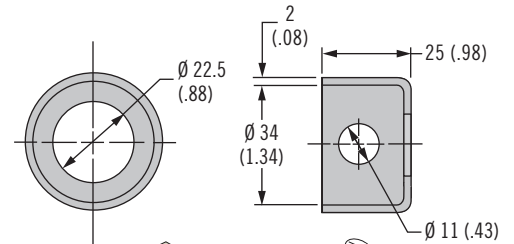

Type	Part Number
Padlock bracket square	E3-77-101-31
Padlock bracket round	E3-77-102-31

Pull Tab (13.5mm size)

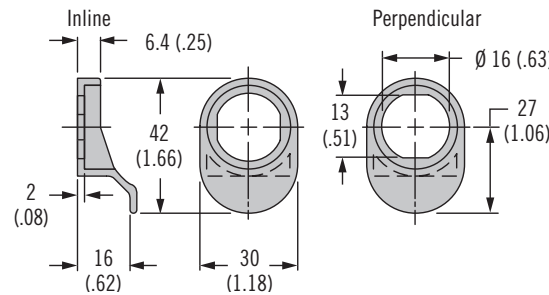

Pull Tab (19.1mm size)

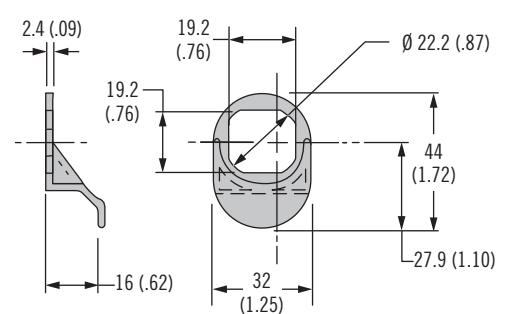

Type	Part Number
Pull tab 13.5 mm size – In-line	E3-27-61
Pull tab 13.5 mm size – Perpendicular	E3-27-62
Pull tab 19.1 mm size	E3-27-1

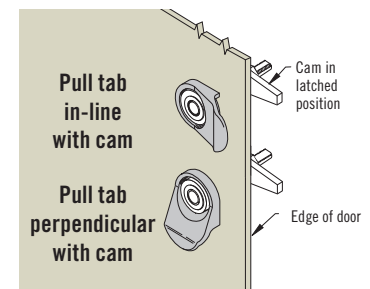

Material and Finish

Zinc alloy

Installation Notes

For use in double skin doors.
Product standard panel cutout in outer door and for the inner door produce 25 (.98) hole for sleeve nut

Sleeve Nut M22 Thread (for 19.1mm size E3 only)

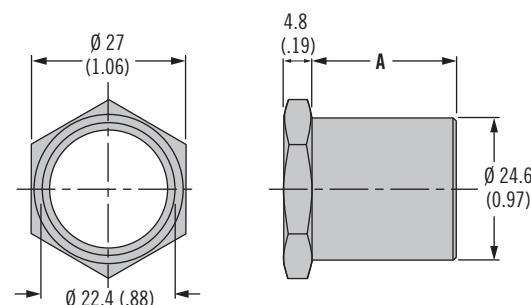

Type	A	Part Number
Sleeve Nut – short	12.7 (.50)	E3-34-263-36
Sleeve Nut - long	25 (.98)	E3-34-264-36

Dimensions in millimeters (inch) unless otherwise stated



Tool Operated Key



- F** Finish
- 1 Plated zinc
 - 2 Natural zinc
 - 3 Nylon black

E3 - H - F

H Head style

Southco® Tubular Key

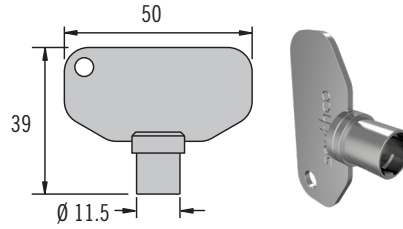

Material and Finish

Tool Operated: Zinc, bright nickel plate or natural and nylon, black
 Tubular: Steel, bright nickel plate

2	3	4	7	8
3 (.11) Double bit	7 (.28) Triangle	7 (.28) Square	8 (.32) Triangle	8 (.32) Square recess
9	10	11	12	14
5 (.19) Double bit	8 (.32) Square male	Bellcore electronics	Bellcore 216	Railway Standard
15	16	17	25	E3-5-15
Railway male	7 (.28) Tapered triangle	17 (.67) square	6 (.24) Square male	Southco® Tubular 19.1 (.75)

E3-26-819-15

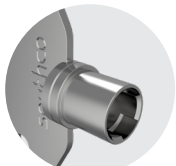

Southco® Tubular
13.5 (.65)

Overmolded Keys

Key CH751
PK-10-10-05



Key R001
PK-10-10-05-KR001



Flat Keys

Key CH751
PK-10-10



Part Number

Overmolded key CH751:

Single: PK-10-10-05

Pair: PK-10-01-05

Overmolded key R001:

Single: PK-10-10-05-KR001

Pair: PK-10-01-05-KR001

Flat keys

Single: PK-10-10

Pair: PK-10-01