



# E5 Cam Latches

## Overview

### Modularity and simplicity in action

The *SOUTHCO*® E5 cam latch is a highly modular and easy to configure solution, suitable for a wide range of applications. By changing any of the three basic components (access style driver, latch body or cam) in either geometry or material, the E5 can be easily adjusted to suit most applications.

#### Product features

- Cost effective, easy to design and install
- Multiple material and access options to suit multiple needs
- Suitable to meet NEMA 4 / IP65 sealing standards
- Corrosion-resistant materials available
- Highly modular and configurable

#### ➤ Match material and finish options for style and functionality requirements

A variety of materials and finishes to complement your application.

Die-cast zinc latch bodies standard finishes:



Chrome plated



Black powder coated

Corrosion resistant materials available



316  
Stainless steel



Glass-filled  
nylon, black



304  
Stainless steel

#### ➤ Select one of these four styles to fit your access requirements

There are four basic E5 styles to meet specific door configuration and mounting requirements in terms of design, depth, surface protrusion and operation style.

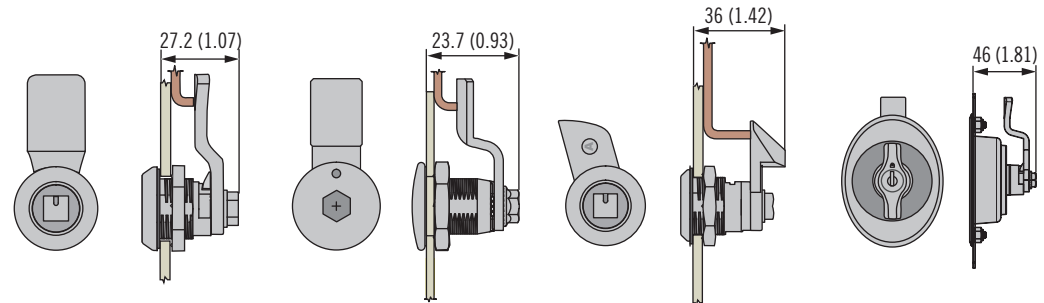

#### E5 Standard

Industry standard, highly modular and configurable options in a wide choice of materials, finishes and access styles. (See page 152)

#### E5 Low Profile

Stylish, low profile design. Tool and hand operated access styles in zinc alloy chrome plated or black powder coated. (See page 156)

#### E5 Push-to-Close

Standard E5 with the added functionality of a spring-loaded cam or actuator for single or multi-point operation. Provides quicker turn-to-open, push-to-close action. (See page 166)

#### E5 Flush Cup Wing Knob

Stylish oval cup design. Provides a clean, flush outer surface. Ideal for multi-point actuation of large doors in aesthetically pleasing applications. (See page 164)

➤ Choose from a wide range of operating styles to fit application and industry requirements.

- Convenient hand-operated wing knob, T and L-handle styles for easy hand access
- Tool operated for restricted access, flush-mount or low-profile clearances, and industry-specific standards
- Key operated for added security

**Hand operable**

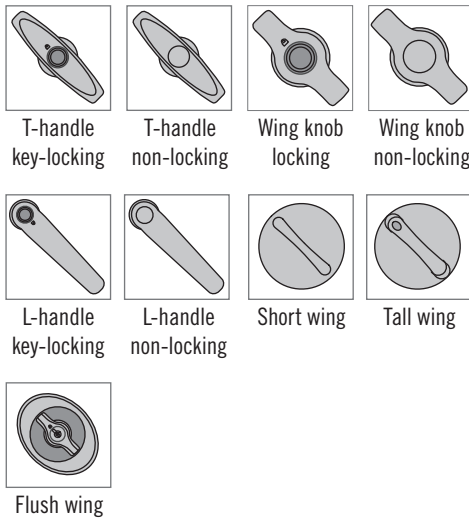

**Tool / key operable**

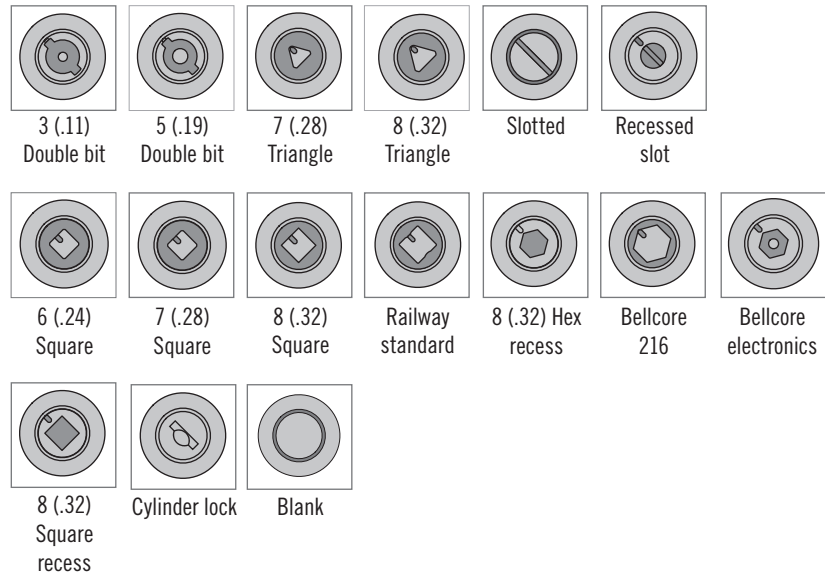

➤ Determine your grip options for a perfect fit

Total grip includes the dimensions of all elements in-between the mounting surface of the latch and the latch's contact surface on the frame - including door thickness, compressed seals and gaskets, accessories, frame offset, etc.

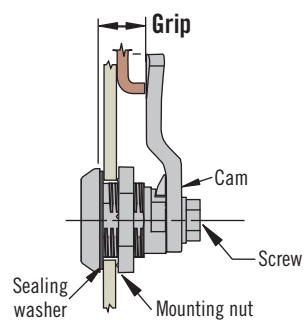

Selecting the right cam for the E5 is easy once the total grip is known. Southco provides a wide selection of standard cams in many grip increments, and special ones like hook and push-to-close cams. Standard cams provide vibration resistance and grip variation tolerance.

**Installation**

Some *SOUTHCO*® E5 latches are shipped latch and cam separately and some completely pre-assembled. See product pages for details.

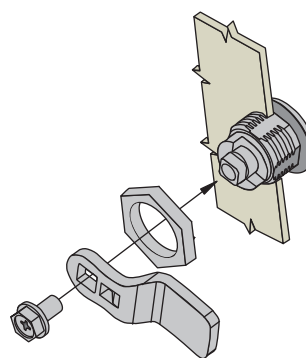

**E5 Standard**  
Latch and cam shipped separately.

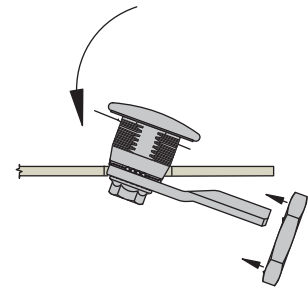

**E5 Low Profile**  
Latch and cam shipped pre-assembled.



# E5 Cam Latch

Stainless steel · Tool operated · Fixed grip

- Single hole install
- Latched / unlatched indicator
- EN 45545-3 E60 Compliant

### Material and Finish

Stainless steel, 304 or 316 grade

### Performance Details

Maximum static load:

304 Stainless steel 550 N (124 lbf)

316 Stainless steel 670 N (150 lbf)

### Sealing Notes

NEMA 4 / IP65 achieved using gasket supplied

### Installation Notes

Mounting nut:

Maximum tightening torque:

20 N·m (177 in·lbf)

Screw Maximum tightening torque

10 N·m (90 in·lbf)

### Keys and Accessories

See page 121 and 169-175

### Part Number Selection

See table

Order latch and cam separately

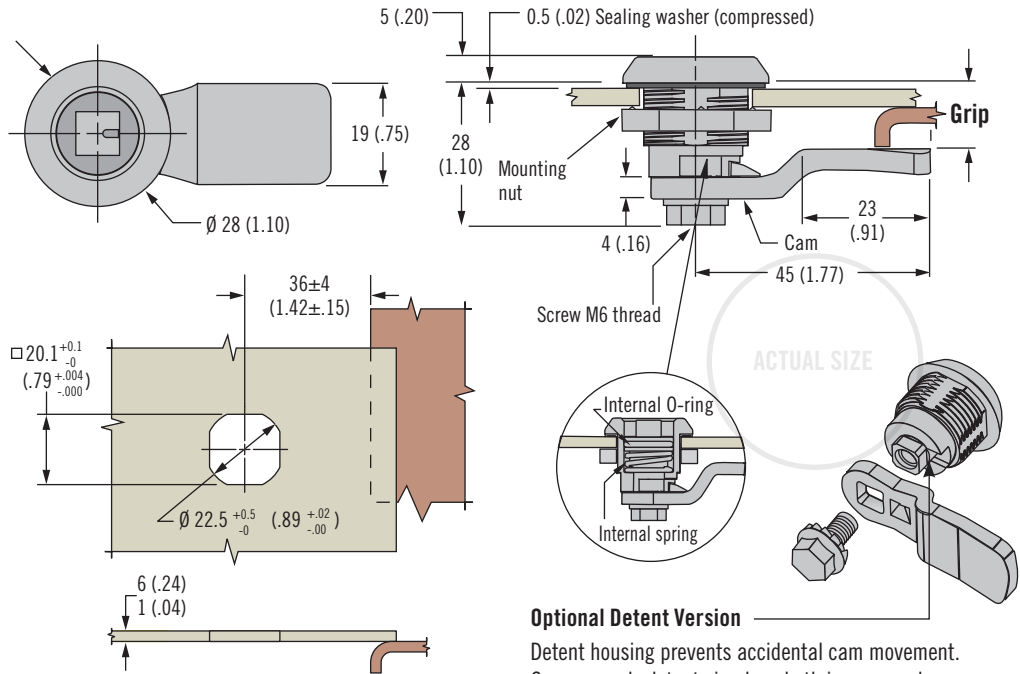

### H Head Styles

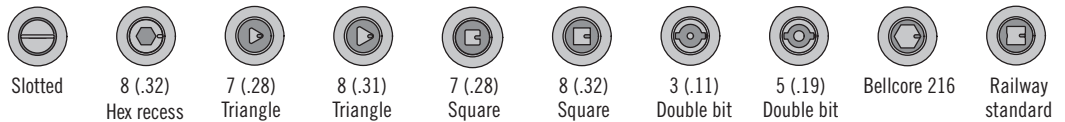

### Optional Detent Version

Detent housing prevents accidental cam movement. Cam securely detents in place both in open and closed positions.

**Latch Part Number (no cam)**

**E5 - B - H M - UU1**

**B Body**

- 6 Normal housing
- 32 Detented housing

**H Head style**

- 00 Slotted
- 01 8 (.32) Hex recess
- 02 7 (.28) Triangle
- 03 8 (.32) Triangle
- 04 7 (.28) Square
- 05 8 (.32) Square
- 06 3 (.11) Double bit
- 07 5 (.19) Double bit
- 13 Bellcore 216
- 22 Railway standard

**M Material**

- 24 304 Stainless steel
- 27 316 Stainless steel

Cam Part Number Table (order separately from latch)

Grip +2(.08) - 0 (.00)	Part Number		Grip +2(.08) - 0 (.00)	Part Number		Grip +2(.08) - 0 (.00)	Part Number		Grip +2(.08) - 0 (.00)	Part Number	
	304 Stainless steel	316 Stainless steel		304 Stainless steel	316 Stainless steel		304 Stainless steel	316 Stainless steel		304 Stainless steel	316 Stainless steel
4 (.16)	E5-8003	E5-9003	14 (.55)	E5-8008	E5-9008	24 (.94)	E5-8013	E5-9013	34 (1.34)	E5-8018	E5-9018
6 (.24)	E5-8004	E5-9004	16 (.63)	E5-8009	E5-9009	26 (1.02)	E5-8014	E5-9014	36 (1.42)	E5-8019	E5-9019
8 (.31)	E5-8005	E5-9005	18 (.71)	E5-8010	E5-9010	28 (1.10)	E5-8015	E5-9015	38 (1.50)	E5-8020	E5-9020
10 (.39)	E5-8006	E5-9006	20 (.79)	E5-8011	E5-9011	30 (1.18)	E5-8016	E5-9016	40 (1.57)	E5-8021	E5-9021
12 (.47)	E5-8007	E5-9007	22 (.87)	E5-8012	E5-9012	32 (1.25)	E5-8017	E5-9017	42 (1.65)	E5-8022	E5-9022



# E5 Cam Latch

Zinc · Tool operated · Adjustable grip

- Single hole install
- Latched / unlatched indicator
- Easy grip adjustment
- Tool operated for security
- Sensor Cam Option - for monitoring door and latch status

### Material and Finish

Zinc alloy, powder coated or chrome plated and steel, zinc plated

### Performance Details

Maximum static load: 330 N (74 lbf)

### Installation Notes

Position cam so latching function can be achieved comfortably by hand. Recommended tightening torque for mounting nut is 10 N·m (88 in·lbf) max, and jam nut is 7 N·m (62 in·lbf)

### Sealing Notes

NEMA 4 / IP65 achieved using gasket supplied

### Keys and Accessories

See page 121 and 169-175

### Part Number Selection

See table

Order latch and cam separately

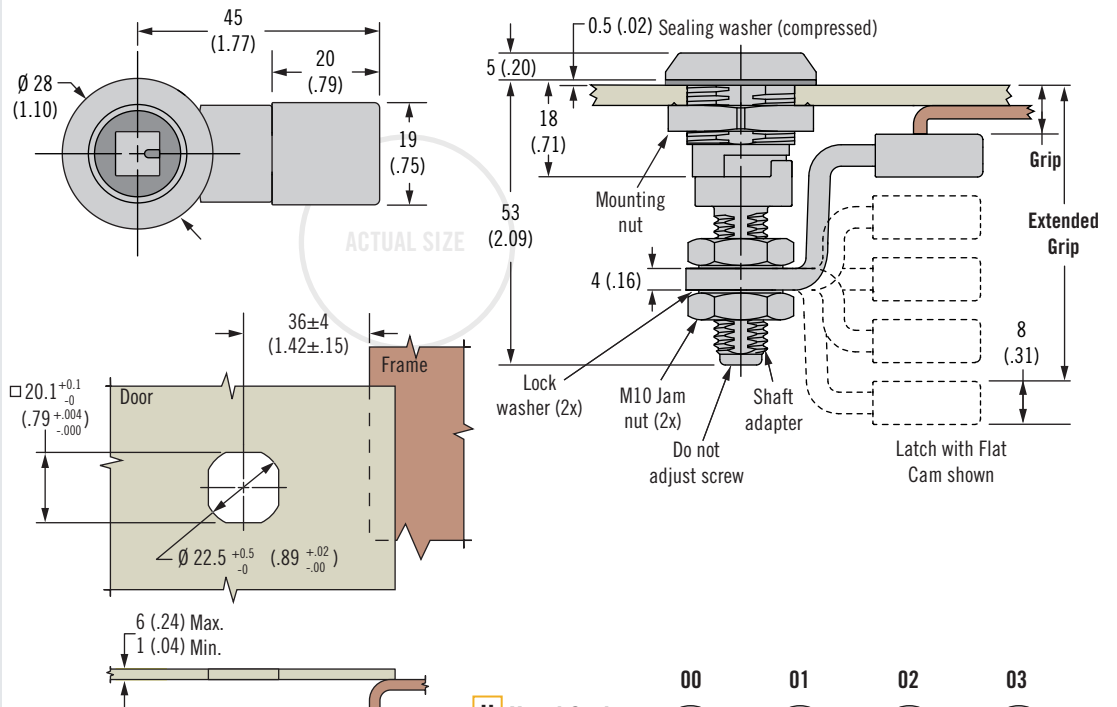

### H Head Styles

<b>00</b>  Slotted	<b>01</b>  8 (.32) Hex recess	<b>02</b>  7 (.28) Triangle	<b>03</b>  8 (.32) Triangle
<b>04</b>  7 (.28) Square	<b>05</b>  8 (.32) Square	<b>06</b>  3 (.11) Double bit	<b>07</b>  5 (.19) Double bit
<b>13</b>  Bellcore 216	<b>19</b>  Bellcore electronics	<b>21</b>  Recessed slot (tamper resistant)	<b>22</b>  Railway standard
<b>24</b>  6 (.24) Square recess	<b>08</b>  8 (.32) Square recess		

Latch Part Number (no cam)

**E5 - 6 - H F - 01**

### F Finish

- 2 Bright chrome
- 5 Black powder coated

### Latch Can Be Used With ES-01 Universal Latch Sensor for Monitoring Latch and Door Status

(see page 47A)

Requires: E5-6 Latch, E5-400X-XXX Sensor Cam and Universal Latch Sensor.

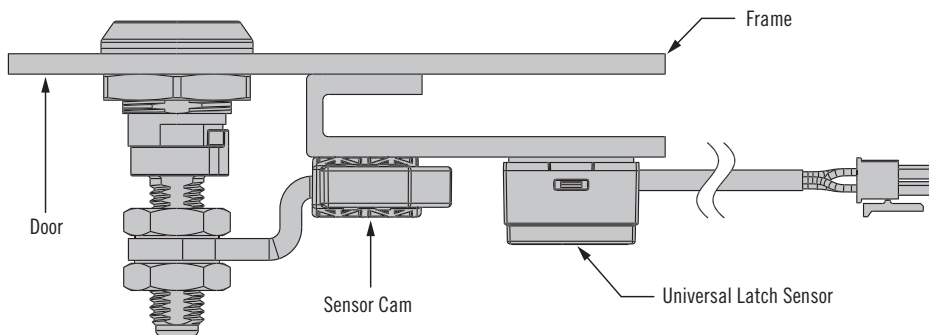

Dimensions in millimeters (inch) unless otherwise stated

# E5 Cam Latch

## Adjustable grip cam options



Protected Cam Part Number Table (order separately from latch)				
Minimum Grip +2(.08) - 0	Maximum Grip +2(.08) - 0	Offset	Cam Type	Part Number
5 (.20)	16.5 (.65)	Deep Cam	Forward	E5-4001
51 (2.01)	62.5 (2.46)	Deep Cam	Reversed	
16.5 (.65)	28 (1.10)	Cam	Forward	E5-4002
39.5 (1.56)	51 (2.01)	Cam	Reversed	
28 (1.10)	39.5 (1.56)	-	Straight Cam	E5-4003

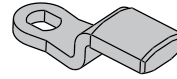

- Protected Cam**
- Stable frame engagement
  - Improved surface contact
  - Minimal frame surface prep

Roller Cam Part Number Table (order separately from latch)				
Minimum Grip +2(.08) - 0	Maximum Grip +2(.08) - 0	Offset	Cam Type	Part Number
0 (0)	5 (.20)	Extra Deep Cam	Forward	E5-4505
54 (2.13)	62.5 (2.46)	Extra Deep Cam	Reversed	
0 (0)	8 (.31)	Deep Cam	Forward	E5-4506
45 (1.89)	58 (2.28)	Deep Cam	Reversed	
8 (.31)	18 (.71)	Medium Cam	Forward	E5-4507
38 (1.50)	48 (1.89)	Medium Cam	Reversed	
18 (.17)	28 (1.10)	Low Cam	Forward	E5-4508
28 (1.10)	38 (1.50)	Low Cam	Reversed	

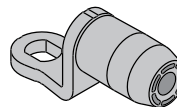

- Roller Cam**
- Reduce operating effort
  - Minimize scratching frame finish
  - Detented feel (with optional Keeper)

Sensor Cam Part Number Table (order separately from latch)					
Minimum Grip +2(.08) / - 0	Maximum Grip +2(.08) / - 0	Offset	Cam Type	Magnet Position	Part Number
3.5 (.14)	15 (.59)	Deep Cam	Forward	Position 1	E5-4001-M01
49.5 (1.95)	61 (2.40)		Reversed	Position 2	E5-4001-M02
				Position 3	E5-4001-M03
15 (.59)	26.5 (1.04)	Cam	Forward	Position 1	E5-4002-M01
38 (1.50)	49.5 (1.95)		Reversed	Position 2	E5-4002-M02
				Position 3	E5-4002-M03
26.5 (1.04)	38 (1.50)	Straight Cam	-	Position 1	E5-4003-M01
				Position 2	E5-4003-M02
				Position 3	E5-4003-M03

- Sensor Cam**
- Stable frame engagement
  - Improved surface contact
  - Works with Southco ES-01 Universal Latch Sensor (page 47A)

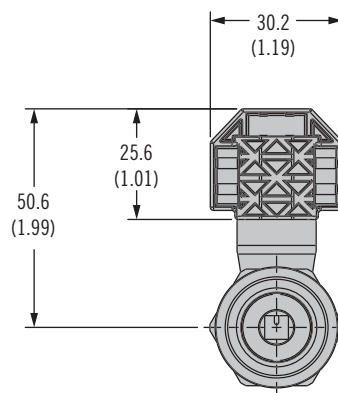
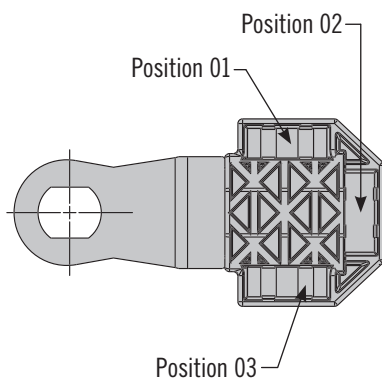

- Single hole install
- Latched / unlatched indicator
- Easy grip adjustment
- Tool operated for security
- Sensor Cam Option - for monitoring door and latch status

### Material and Finish

Zinc alloy, powder coated or chrome plated and steel, zinc plated

### Performance Details

Maximum static load: 330 N (74 lbf)

### Installation Notes

Position cam so latching function can be achieved comfortably by hand. Recommended tightening torque for mounting nut is 10 N·m (88 in·lbf) max, and jam nut is 7 N·m (62 in·lbf)

### Sealing Notes

NEMA 4 / IP65 achieved using gasket supplied

### Keys and Accessories

See page 121 and 169-175

### Part Number Selection

See table  
Order latch and cam separately



# E5 Cam Latch

Zinc · Tool operated · Short Housing · Fixed grip

- Single hole install
- Latched / unlatched indicator
- EN 45545-3 E10 Compliant

### Material and Finish

Zinc alloy, powder coated or chrome plated and steel, zinc plated

### Performance Details

Maximum static load: 330 N (74 lbf)

### Installation Notes

Mounting nut:  
Maximum tightening torque:  
10 N·m (88 in·lbf)

Screw Maximum tightening torque:  
5 N·m (45 in·lbf)

### Sealing Notes

NEMA 4 / IP65 achieved using gasket supplied

### Keys and Accessories

See page 121 and 169-175

### Notes

Suitable for push-to-close action see page 166

### Part Number Selection

See table  
Order latch and cam separately

### Optional Keeper for Roller Cam

Part number E5-74-601-33

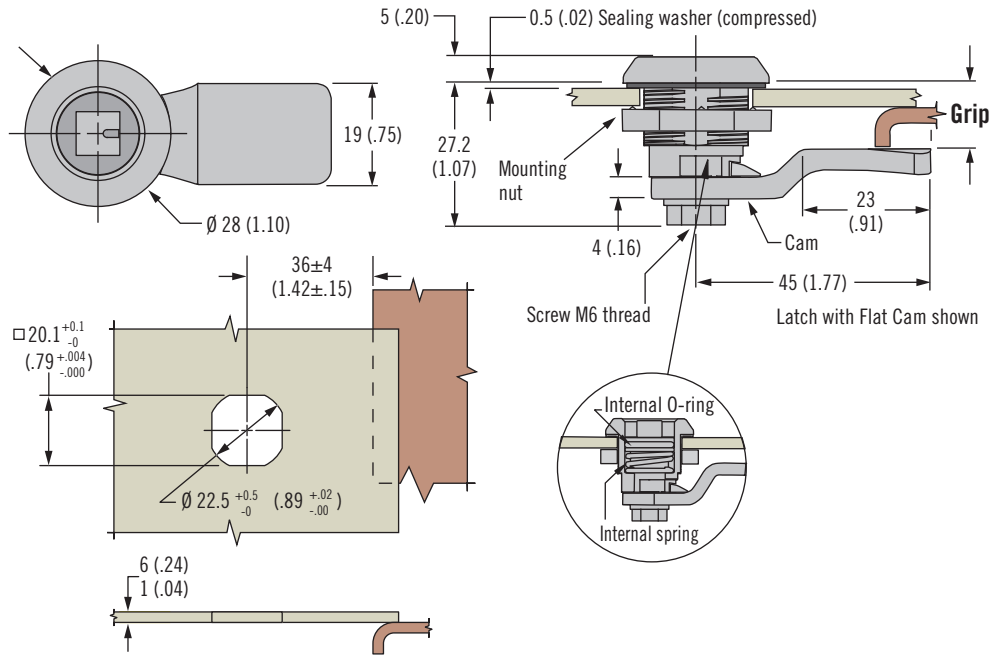

**Latch Part Number (no cam)**

**E5 - 6 - H F - UU1**

**H Head Styles**

00 Slotted	01 Hex recess	02 Triangle	03 Triangle
04 Square	05 Square	06 Double bit	07 Double bit
08 Square recess	13 Bellcore 216	19 Bellcore electronics	21 Recessed slot (tamper resistant)
22 Railway standard	23 Blank	24 Square recess	

**F Finish**

- 2 Bright chrome
- 5 Black powder coated

### Cam Options - See Page 170 Short Housing Table

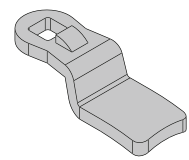

- Standard Cam**
- Stable frame engagement
  - Improved surface contact
  - Minimal frame surface prep

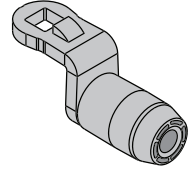

- Roller Cam**
- Reduce operating effort
  - Minimize scratching frame finish
  - Detented feel (with optional Keeper)

# E5 Cam Latch

Zinc · Tool operated · Long Housing · Fixed grip

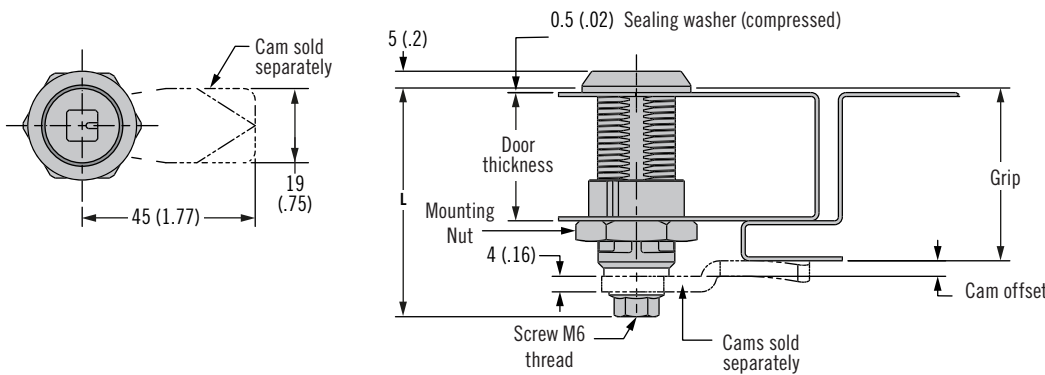

- Single hole install
- Latched / unlatched indicator
- Suitable for thick doors

### Material and Finish

Zinc alloy, powder coated or chrome plated and steel, zinc plated

### Performance Details

Maximum static load: 330 N (74 lbf)

### Installation Notes

Mounting nut:  
Maximum tightening torque:  
10 N·m (88 in·lbf)  
Screw Maximum tightening torque:  
5 N·m (45 in·lbf)

### Sealing Notes

NEMA 4 / IP65 achieved using gasket supplied

### Keys and Accessories

See page 121 and 169-175

### Part Number Selection

See table  
Order latch and cam separately

Compatible with flat and roller cams - See page 171, Long Housing Table for cam part numbers

### Door Preparation

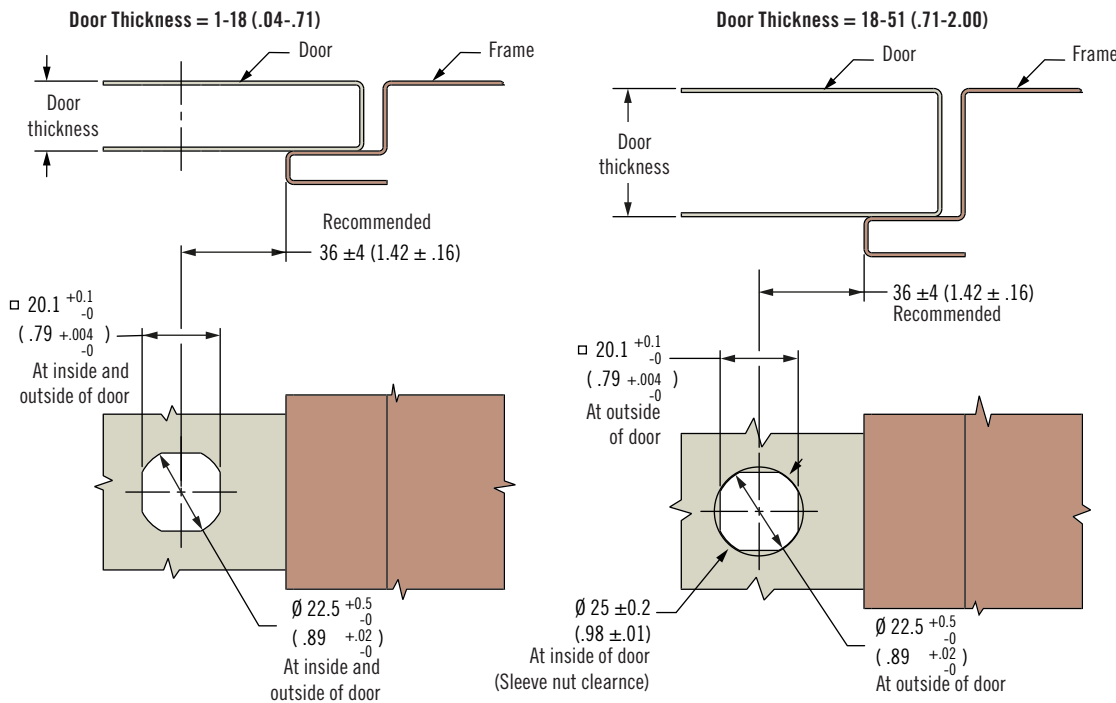

**E5 - 6 A - H F - UU D**

- F Finish**
- 2 Bright chrome
  - 5 Black powder coated

**H Head style** (See for details)

- |                              |  |
|------------------------------|--|
| <b>00</b> Slotted            | <b>08</b> 8 (.32) Square recess            |
| <b>01</b> 8 (.32) Hex recess | <b>13</b> Bellcore 216                     |
| <b>02</b> 7 (.28) Triangle   | <b>19</b> Bellcore Electronics             |
| <b>03</b> 8 (.32) Triangle   | <b>21</b> Recessed slot (tamper resistant) |
| <b>04</b> 7 (.28) Square     | <b>22</b> Railway standard                 |
| <b>05</b> 8 (.32) Square     | <b>23</b> Blank                            |
| <b>06</b> 3 (.11) Double bit | <b>24</b> 6(.24) Square recess             |
| <b>07</b> 5 (.19) Double bit |  |

D	Door Thickness	Grip Range	L
1	1-18 (.04-.71)	5-53 (.20-2.09)	45.5 (1.79)
2	1-18 (.04-.71)	54-82 (2.13-3.23)	68.2 (2.69)
3	18-33 (.71-1.30)	18-66 (.71-2.60)	58.2 (2.29)
4	18-33 (.71-1.30)	68-82 (2.60-3.23)	68.2 (2.69)
5	33-51 (1.30-2.00)	34-82 (1.34-3.23)	68.2 (2.69)

### Optional Keeper for Roller Cam

Part number E5-74-601-33





# E5 Cam Latch Low Profile

Zinc · Tool or hand operated · Fixed grip

- Single hole install
- Latched / unlatched indicator
- Shipped fully assembled
- EN 45545-3 E10 Compliant

### Material and Finish

Zinc alloy, powder coated or chrome plated and steel, zinc plated

### Performance Details

Maximum static load: 330 N (74 lbf)

### Installation Notes

Mounting nut  
Maximum tightening torque:  
10 N·m (88 in·lbf)

### Keys and Accessories

See page 121 and 169-175

### Part Number Selection

See table

Latch is shipped fully assembled

For door thicknesses  
1 - 6 (.039 - .236) grip must  
exceed door thickness by 4 (.157)  
for assembled installation

When sealing option is selected,  
add 0.4 (.02) to grip calculation  
to accommodate sealing washer

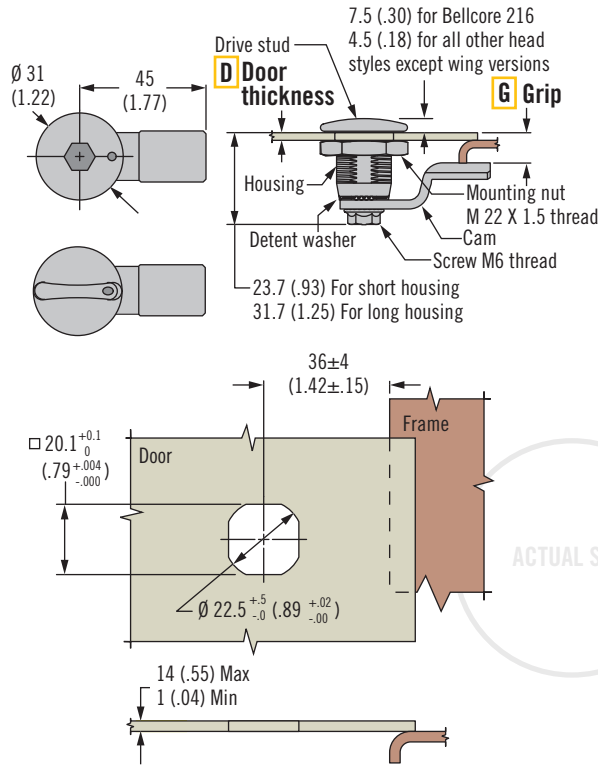

### H Head Styles

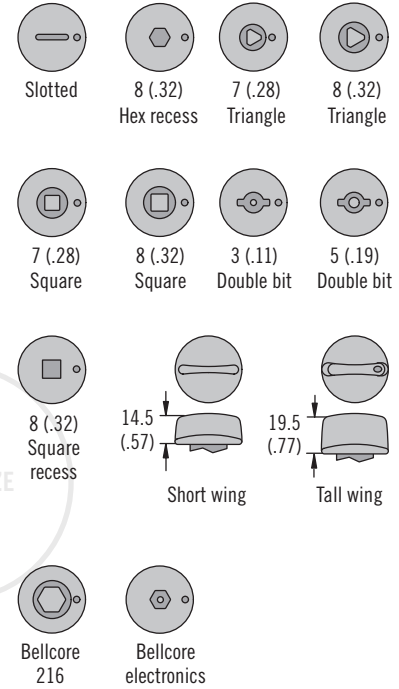

**H Head style**

- 00 Slotted
- 01 8 (.32) Hex recess
- 02 7 (.28) Triangle
- 03 8 (.32) Triangle
- 04 7 (.28) Square
- 05 8 (.32) Square
- 06 3 (.11) Double bit
- 07 5 (.19) Double bit
- 08 8 (.32) Square recess
- 11 Short wing
- 12 Tall wing
- 13 Bellcore 216
- 19 Bellcore Electronics

**F Finish**

- 1 Textured chrome
- 5 Black powder coated

**S Sealing option**

- 0 No o-ring or external seal
- 1 O-ring and external seal to meet NEMA 4/IP65 standards

**E5 - D - H F - G S**

**D Door thickness range**

- 1 1 - 6 (.039 - .236) (short housing supplied)
- 2 1 - 14 (.039 - (.551) (long housing supplied)

G Grip table											
G	Grip		G	Grip		G	Grip		G	Grip	
	Short housing	Long housing		Short housing	Long housing		Short housing	Long housing		Short housing	Long housing
00	Do not use	6 (.24)	05	8 (.31)	16 (.63)	10	18 (.71)	26 (1.02)	15	28 (1.10)	36 (1.42)
01	Do not use	8 (.31)	06	10 (.39)	18 (.71)	11	20 (.79)	28 (1.10)	16	30 (1.18)	38 (1.50)
02	2 (.08)	10 (.39)	07	12 (.47)	20 (.79)	12	22 (.87)	30 (1.18)	17	32 (1.25)	40 (1.57)
03	4 (.16)	12 (.47)	08	14 (.55)	22 (.87)	13	24 (.94)	32 (1.25)	18	34 (1.34)	42 (1.65)
04	6 (.24)	14 (.55)	09	16 (.63)	24 (.94)	14	26 (1.02)	34 (1.34)	19	36 (1.42)	44 (1.73)

If grip falls between two choices, use the smaller option

Dimensions in millimeters (inch) unless otherwise stated

# E5 Cam Latch

Zinc · Shutter · Tool operated · Fixed grip

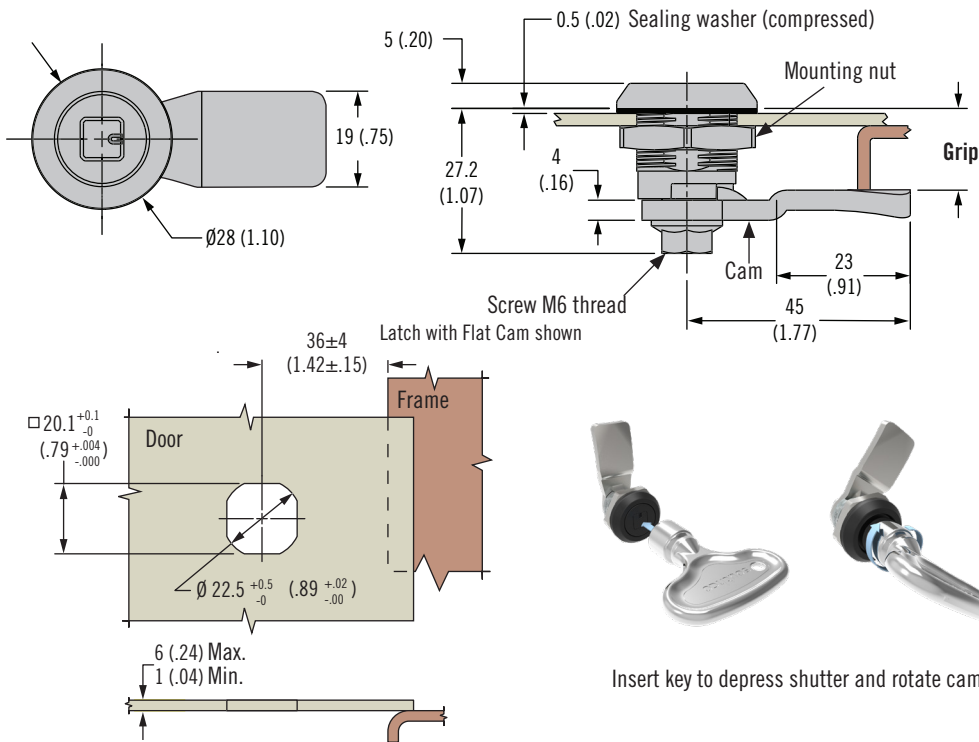

- Single hole install
- Latched / unlatched detent
- Vibration resistant
- EN 61373 Compliant

**Material and Finish**  
Zinc alloy, powder coated or chrome plated and steel, zinc plated

**Performance Details**  
Maximum static load: 330 N (74 lbf)

**Installation Notes**  
Mounting nut maximum tightening torque: 10 N·m (88 in·lbf)  
Screw Maximum tightening torque: 5 N·m (45 in·lbf)

**Sealing Notes**  
NEMA 4 / IP65 achieved using gasket supplied

**Keys and Accessories**  
See page 121 and 169-175

**H Head Styles**

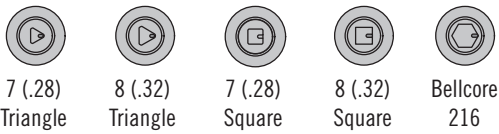

**Latch Part Number (no cam)**

**E5 - 8 - H F - UU1**

- H Head style**
- 02 7 (.28) Triangle
  - 03 8 (.32) Triangle
  - 04 7 (.28) Square
  - 05 8 (.32) Square
  - 13 Bellcore 216

- F Finish**
- 2 Bright chrome
  - 5 Black powder coated

**Part Number Selection**

See table  
Order latch and cam separately

**Cam Part Number Table (order separately from latch)**

Grip	Part Number	Grip	Part Number	Grip	Part Number	Grip	Part Number
4 (.16)	E5-6003	14 (.55)	E5-6008	24 (.94)	E5-6013	34 (1.34)	E5-6018
6 (.24)	E5-6004	16 (.63)	E5-6009	26 (1.02)	E5-6014	36 (1.42)	E5-6019
8 (.31)	E5-6005	18 (.71)	E5-6010	28 (1.10)	E5-6015	38 (1.50)	E5-6020
10 (.39)	E5-6006	20 (.79)	E5-6011	30 (1.18)	E5-6016	40 (1.57)	E5-6021
12 (.47)	E5-6007	22 (.87)	E5-6012	32 (1.25)	E5-6017	42 (1.65)	E5-6022



# E5 Cam Latch

Zinc · Tool or hand operated · Fixed grip · Mini size

- Single hole install
- Compact size
- Minimal panel intrusion

### Material and Finish

Zinc alloy, black powder coated and steel, zinc plated

### Performance Details

Maximum static load: 130 N (29 lbf)

### Sealing Notes

NEMA 4 / IP65 achieved using gasket supplied

### Installation Notes

Mounting nut maximum tightening torque: 5 N·m (45 in-lbf)

Screw Maximum tightening torque: 1 N·m (9 in-lbf)

### Key part numbers

- 6mm (.24) Triangle
- E3-19-3
- 6mm (.24) Square
- E3-20-3

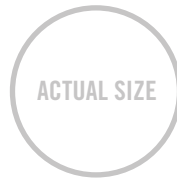
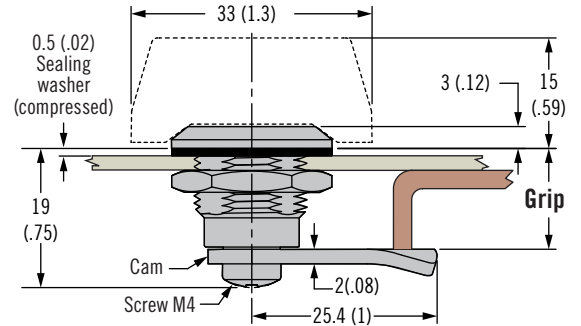
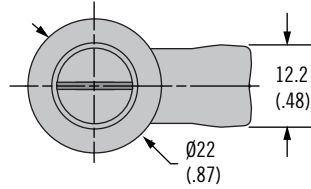

### H Head style

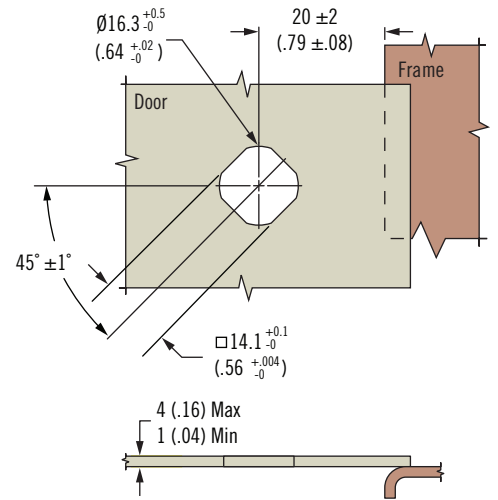
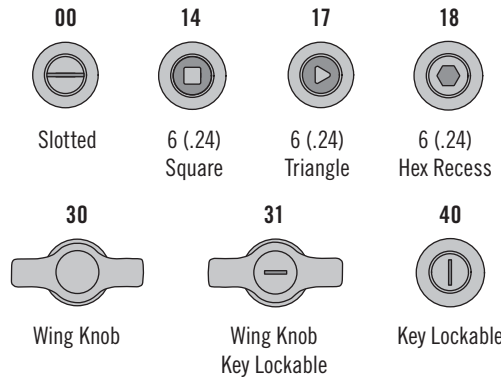

### Part Number Selection

Order latch and cam separately

Latch Part Number (no cam)

**E5 - M - H F - UU1 - 1 K**

### H Head style

- 00** Slotted (Omit last two digits of part number)
- 14** Square 6mm (Omit last two digits of part number)
- 17** Triangle 6mm (Omit last two digits of part number)
- 18** Hex Recess 6mm (Omit last two digits of part number)
- 30** Wing Knob (Omit last two digits of part number)
- 31** Wing Knob, Key Lockable, Keyed CH751
- 40** Key Lockable, Keyed CH751

### F Finish

- 2** Bright chrome
- 5** Black powder coated

### K Key Options

- 0** No Keys Included, Order Separately
- 1** 1 Key Supplied

### Cam Part Number Table (order separately from latch)

Grip	Part Number	Grip	Part Number
4 (.16)	E5-3005	16 (.63)	E5-3011
6 (.24)	E5-3006	18 (.71)	E5-3012
8 (.31)	E5-3007	20 (.79)	E5-3013
10 (.39)	E5-3008	22 (.87)	E5-3014
12 (.47)	E5-3009	24 (.94)	E5-3015
14 (.55)	E5-3010	26 (1.02)	E5-3016

# E5 Cam Latch

Glass-filled nylon · Tool or hand operated · Fixed grip

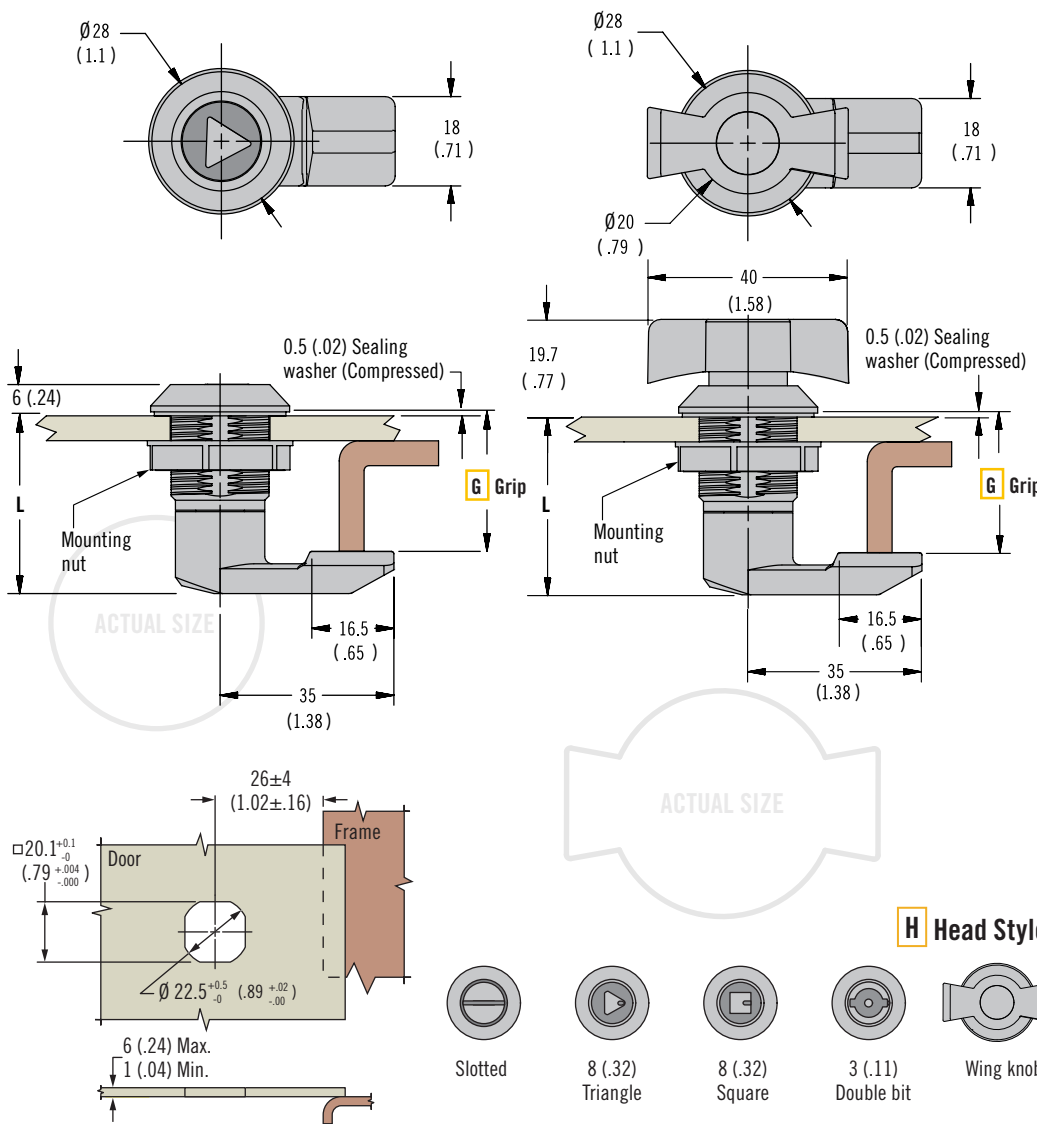

- Single hole install
- Corrosion-resistant materials

### Material and Finish

Glass-filled nylon and Stainless steel

### Performance Details

Average ultimate load:  
300 N (68 lbf)

### Installation Notes

Mounting nut  
Maximum tightening torque:  
4.25 N-m (38 in-lbf)

### Sealing Notes

NEMA 4 / IP65 achieved using gasket supplied

### Keys and Accessories

See page 121 and 169-175

### Latch Part Number

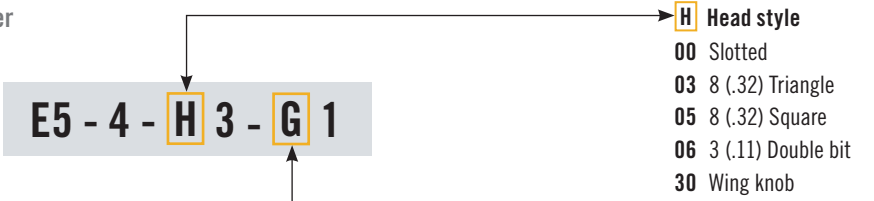

### Part Number Selection

See table

Grip table				Grip table				Grip table			
Total Grip	G	L	Max. Door Thickness for Assembled Latch	Total Grip	G	L	Max. Door Thickness for Assembled Latch	Total Grip	G	L	Max. Door Thickness for Assembled Latch
16 (.63)	16	28.1 (1.1)	5 (.20)	24 (.94)	24	34.6 (1.36)	6 (.24)	30 (1.18)	30	40.6 (1.6)	6 (.24)
18 (.71)	18	28.1 (1.1)	5 (.20)	25 (.98)	25	35.6 (1.4)	6 (.24)	32 (1.26)	32	42.6 (1.68)	6 (.24)
20 (.79)	20	28.1 (1.1)	6 (.24)	26 (1.02)	26	36.6 (1.44)	6 (.24)	34 (1.34)	34	44.6 (1.76)	6 (.24)
22 (.87)	22	32 (1.26)	6 (.24)	28 (1.10)	28	38.6 (1.52)	6 (.24)	36 (1.42)	36	46.6 (1.83)	6 (.24)



# E5 Cam Latch

Zinc · L-handle · Hand operated · Fixed grip · Short Housing

- Single hole install
- Multiple key codes
- Padlockable option

### Material and Finish

Zinc alloy, powder coated or chrome plated and steel, zinc plated

### Performance Details

Maximum static load: 330 N (74 lbf)

### Sealing Notes

NEMA 4 / IP65 achieved using gasket supplied

### Installation Notes

Mounting nut: Maximum tightening torque:

10 N·m (88 in·lbf)

Screw maximum tightening torque:

5 N·m (45 in·lbf)

### Keys

See page 121

### Notes

Suitable for push-to-close action see page 166

For lock core selection and a complete overview of the *SOUTHCO*® Key-Choice System see page 190

For adjustable grip versions see page 176

### Part Number Selection

Order latch, cam, and padlock hasp separately.

Compatible with standard and roller cams. See page 170, Short Housing Table for cam part numbers

Padlock hasp part number:

CW actuation: E5-75-601-86

CCW actuation: E5-75-602-86

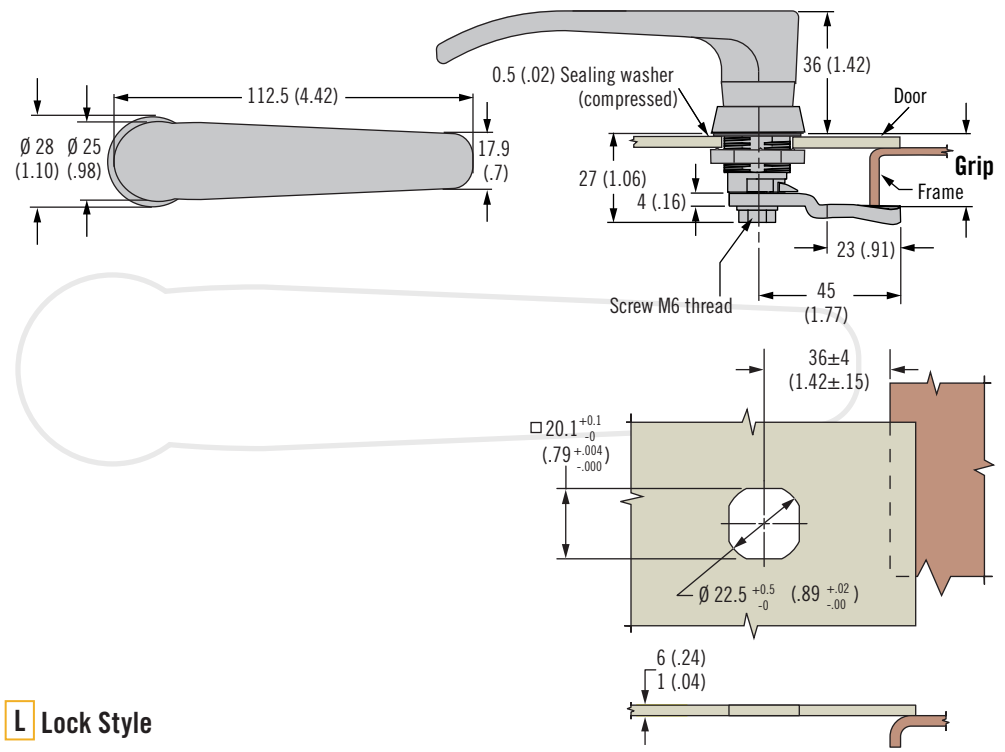

### L Lock Style

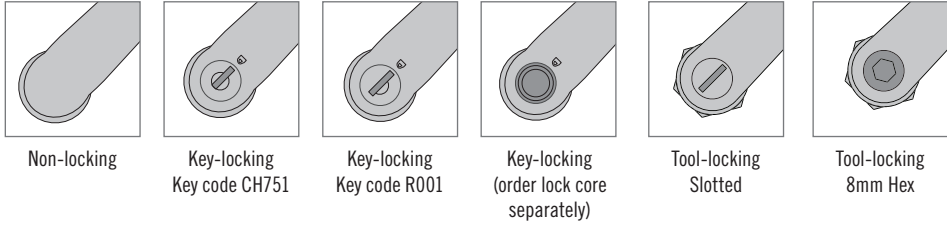

### Latch Part Number (no cam)

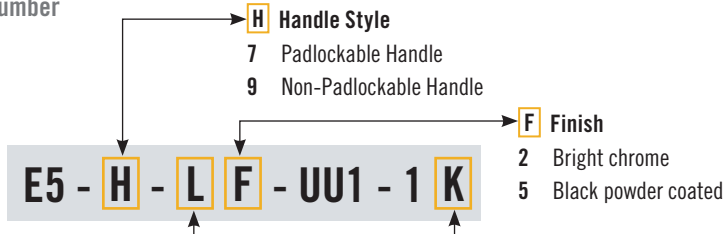

### L Lock style

- 70 Non-locking (omit last two digits of part number)
- 71 Keyed CH751 (lock core finish matches handle finish)
- 72 Keyed R001 (stainless steel scalp shuttered)
- 73 Without lock core (omit last two digits of part number)  
Order lock core separately, see page 190
- 100 Tool Locking, Slotted (omit last two digits of part number)
- 101 Tool Locking, 8mm Hex (omit last two digits of part number)

### K Key options

- 0 No keys supplied (order separately, see page 121)
- 3 1 Overmolded key supplied



# E5 Cam Latch

Zinc · L-handle · Hand operated · Fixed grip · Long Housing

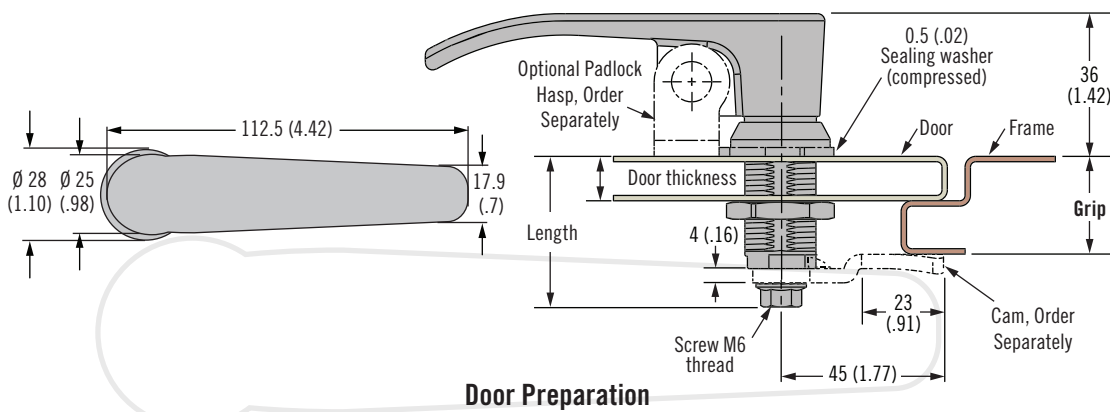

- Suitable for thick doors
- Single hole install
- Multiple key codes
- Padlockable option

### Material and Finish

Zinc alloy, powder coated or chrome plated and steel, zinc plated

### Performance Details

Maximum static load: 330 N (74 lbf)

### Sealing Notes

NEMA 4 / IP65 achieved using gasket supplied

### Installation Notes

Mounting nut: Maximum tightening torque:

10 N·m (88 in·lbf)

Screw maximum tightening torque:

5 N·m (45 in·lbf)

### Keys

See page 121

For lock core selection and a complete overview of the *SOUTHCO*® Key-Choice System see page 190

### Part Number Selection

Order latch, cam, and padlock hasp separately.

Compatible with standard and roller cams. See page 171, Long Housing Table for cam part numbers

Padlock hasp part number:

CW actuation: E5-75-601-86

CCW actuation: E5-75-602-86

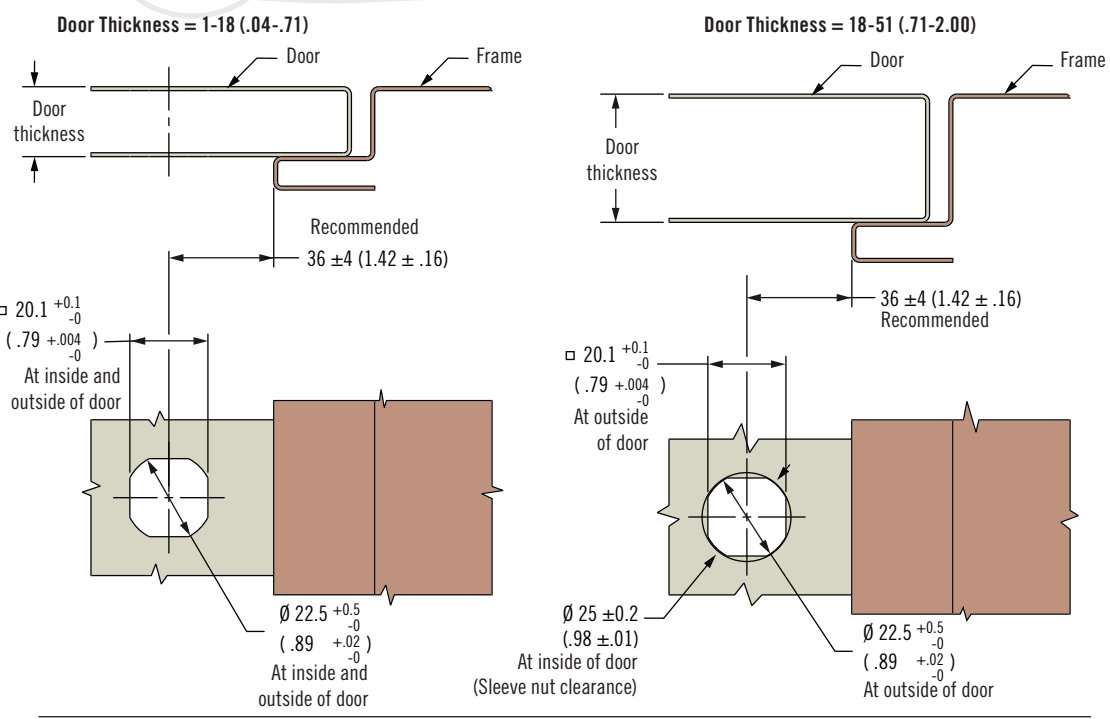

### Latch Part Number

(no cam)

#### H Handle Style

- 7 Padlockable Handle
- 9 Non-Padlockable Handle

#### F Finish

- 2 Bright chrome
- 5 Black powder coated

**E5 - HA - L F - UUD - 1 K**

#### K Key options

- 0 No keys supplied (order separately, see page 121)
- 3 1 Overmolded key supplied

#### L Lock style (See page 160)

- 70 Non-locking (omit last two digits of part number)
- 71 Keyed CH751 (lock core finish matches handle finish)
- 72 Keyed R001 (stainless steel scalp shuttered)
- 73 Without lock core (omit last two digits of part number)  
Order lock core separately, see page 190
- 100 Tool Locking, Slotted (omit last two digits of part number)
- 101 Tool Locking, 8mm Hex (omit last two digits of part number)

D	Door thickness	Grip range	Length
1	1-18 (.04-.71)	5-53 (.20-2.09)	45.5 (1.79)
2	1-18 (.04-.71)	54-82 (2.13-3.23)	68.2 (2.69)
3	18-33 (.71-1.30)	18-66 (.71-2.60)	58.2 (2.29)
4	18-33 (.71-1.30)	68-82 (2.60-3.23)	68.2 (2.69)
5	33-51 (1.30-2.00)	34-82 (1.34-3.23)	68.2 (2.69)



Dimensions in millimeters (inch) unless otherwise stated

[www.southco.com/E5](http://www.southco.com/E5)



# E5 Cam Latch

Zinc · T-handle · Hand operated · Fixed grip

- Single hole install
- Multiple key codes

### Material and Finish

Zinc alloy, powder coated or chrome plated and steel, zinc plated

### Performance Details

Maximum static load: 330 N (74 lbf)

### Sealing Notes

NEMA 4 / IP65 achieved using gasket supplied

### Installation Notes

Mounting nut:  
Maximum tightening torque:  
10 N·m (88 in·lbf)

Screw:  
Maximum tightening torque:  
5 N·m (45 in·lb)

### Keys

See page 121

### Notes

Suitable for push-to-close action see page 166

For adjustable grip versions see page 208

For lock core selection and a complete overview of the *SOUTHCO*® Key-Choice System see page 190

### Part Number Selection

Order latch and cam separately

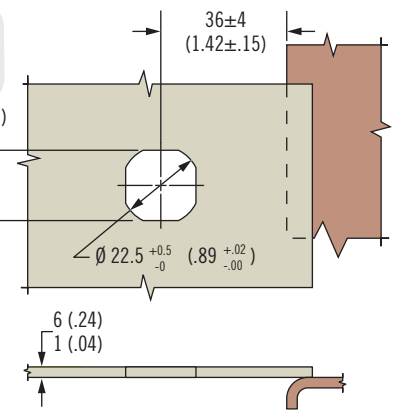
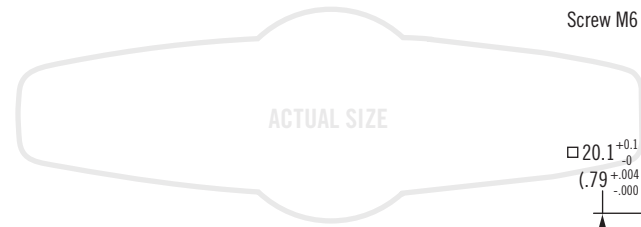
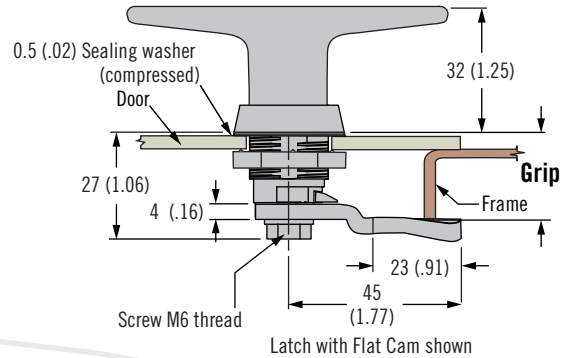
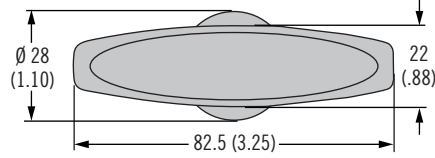

### L Lock Style

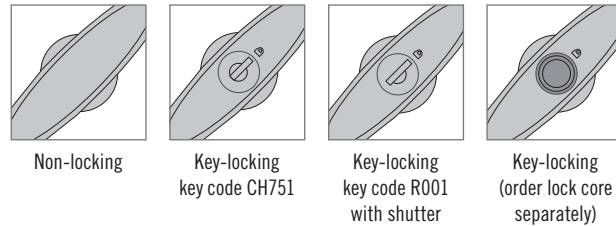

Latch Part Number (no cam)

**E5 - 9 - L F - UU1 - 1 K**

- F Finish**
- 2 Bright chrome
  - 5 Black powder coated

- L Lock style**
- 60 Non-locking (omit last two digits of part number)
  - 61 Keyed CH751 (lock core finish matches handle finish)
  - 62 Keyed R001 (stainless steel scalp shuttered)
  - 63 Without lock core (omit last two digits of part number)  
Order lock core separately, see page 190
- K Key options**
- 0 No keys supplied (order separately, See page 121)
  - 3 1 Overmolded key supplied

Cam Part Number Table (order separately from latch)

Grip	Part Number	Grip	Part Number	Grip	Part Number	Grip	Part Number
4 (.16)	E5-6003	14 (.55)	E5-6008	24 (.94)	E5-6013	34 (1.34)	E5-6018
6 (.24)	E5-6004	16 (.63)	E5-6009	26 (1.02)	E5-6014	36 (1.42)	E5-6019
8 (.31)	E5-6005	18 (.71)	E5-6010	28 (1.10)	E5-6015	38 (1.50)	E5-6020
10 (.39)	E5-6006	20 (.79)	E5-6011	30 (1.18)	E5-6016	40 (1.57)	E5-6021
12 (.47)	E5-6007	22 (.87)	E5-6012	32 (1.25)	E5-6017	42 (1.65)	E5-6022

If grip falls between two choices, use the smaller option

# E5 Cam Latch

## Zinc · Wing style · Fixed grip



Wing (Latch with Flat Cam shown)

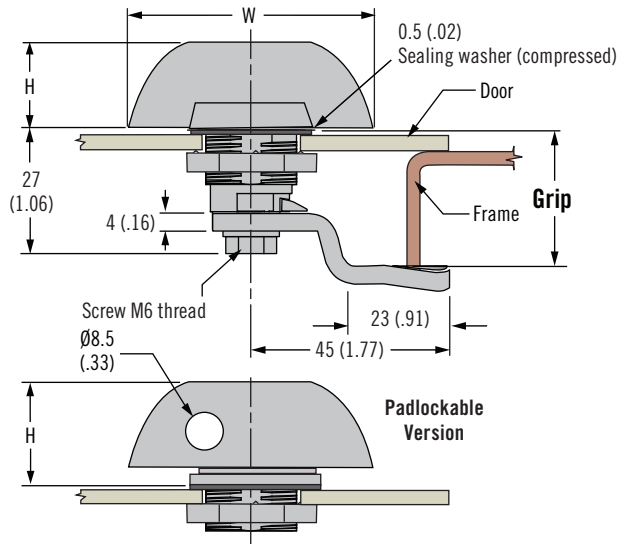
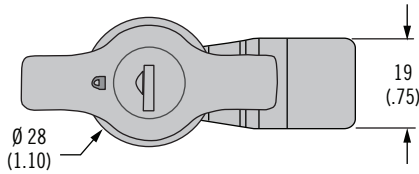

### L Lock Styles

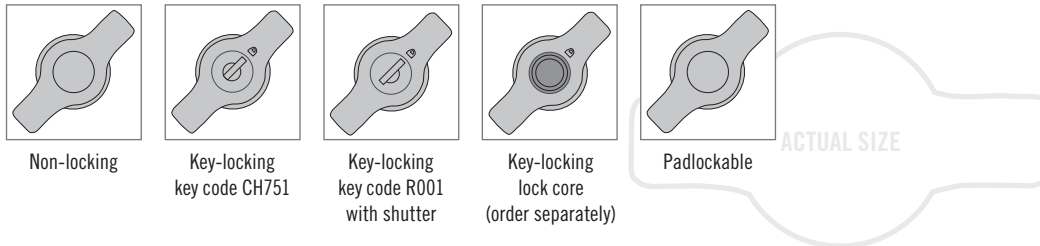

### Latch Part Number (no cam)

Latch Part Number	Lock Style	H	W
E5-9-305-UU1	Non-locking	21 (.83)	56 (2.2)
E5-9-315-UU1-1 <b>K</b>	Key-locking black lock core keyed alike CH751	21 (.83)	56 (2.2)
E5-9-335-UU1	Without lock core, order lock core separately, see page 190	21 (.83)	56 (2.2)
E5-9-355-UU1-1 <b>K</b>	Key-locking stainless steel scalp and shuttered lock core keyed alike R001	23 (.91)	56 (2.2)
E5-9-375-UU1	Non-locking	16.3 (.64)	50 (1.97)
E5-9-515-UU1	Padlockable, Type A clockwise to latch	24 (.94)	56 (2.2)
E5-9-525-UU1	Padlockable, Type B counter-clockwise to latch	24 (.94)	56 (2.2)

### Cam Part Number

**E5 - 6 L G**

**L Lock style**  
 0 Non-locking or Key-locking  
 1 Padlockable

### **K** Key options

- 0 No keys supplied (order separately, see page 120)
- 3 1 Overmolded key supplied

### **G** Grip

Grip	<b>G</b>	Grip	<b>G</b>	Grip	<b>G</b>	Grip	<b>G</b>
4 (.16)	03	14 (.55)	08	24 (.94)	13	34 (1.34)	18
6 (.24)	04	16 (.63)	09	26 (1.02)	14	36 (1.42)	19
8 (.31)	05	18 (.71)	10	28 (1.10)	15	38 (1.50)	20
10 (.39)	06	20 (.79)	11	30 (1.18)	16	40 (1.57)	21
12 (.47)	07	22 (.87)	12	32 (1.25)	17	42 (1.65)	22

- Single hole install
- Multiple key codes
- Easy finger grip

### Material and Finish

Zinc alloy, black powder coated and steel, zinc plated

### Performance Details

Maximum static load: 330 N (74 lbf)

### Sealing Notes

NEMA 4 / IP65 achieved using gasket supplied

### Installation Notes

Mounting nut maximum tightening torque: 10 N·m (88 in·lbf)

Screw Maximum tightening torque: 5 N·m (45 in·lb)

### Keys

See page 120

### Notes

Wing style suitable for push-to-close action see page 166

For lock core selection and a complete overview of the *SOUTHCO*® Key-Choice System see page 190

### Part Number Selection

Order latch and cam separately



# E5 Cam Latch

Zinc · Flush cup wing style · Hand operated · Fixed grip

- Low profile
- Multiple key code options

## Material and Finish

Zinc alloy, powder coated and steel, zinc plated

## Performance Details

Maximum static load: 330 N (74 lbf)

## Installation Notes

Mounting nuts 10-24 UNC (supplied)

Maximum tightening torque: 3 N·m (25 in·lbf)

Screw maximum tightening torque: 5 N·m (45 in·lb)

## Keys

See page 121

## Notes

Two point push-to-close action: Internal spring causes return of wing knob and actuator to original latched position when wing knob is released after opening. Ideal for use with cables and rotary latches.

For lock core selection and a complete overview of the *SOUTHCO*® Key-Choice System see page 190

## Single Point

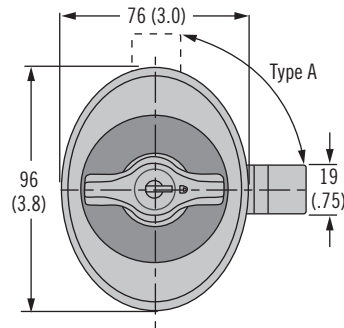

## Maximum door thickness

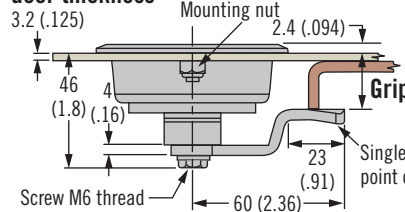

## Two Point (for use with rods)

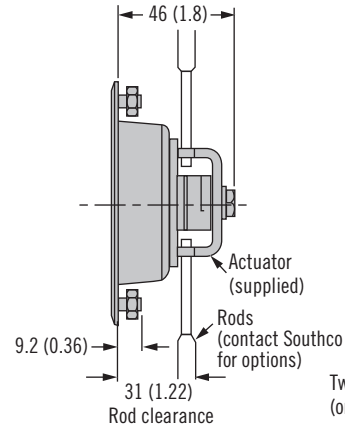

## Two Point Push-to-Close Action (spring-loaded)

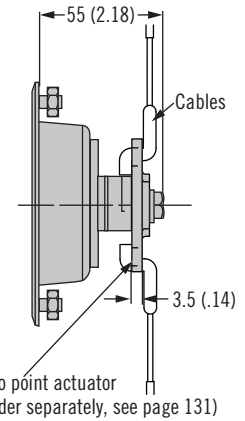

## Actuator (supplied)

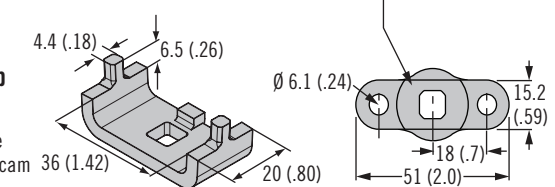

## Type A (reverse frame for type B)

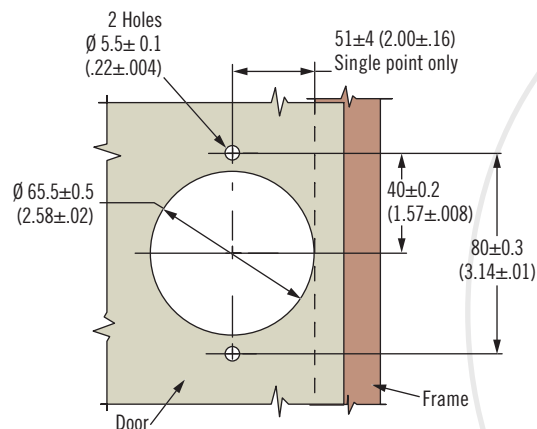

ACTUAL SIZE

**R** Rotation

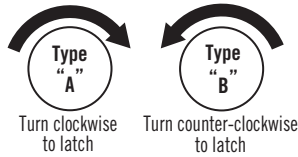

**L** Lock Styles

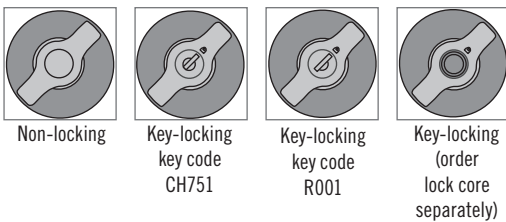

Latch Part Number (no cam)

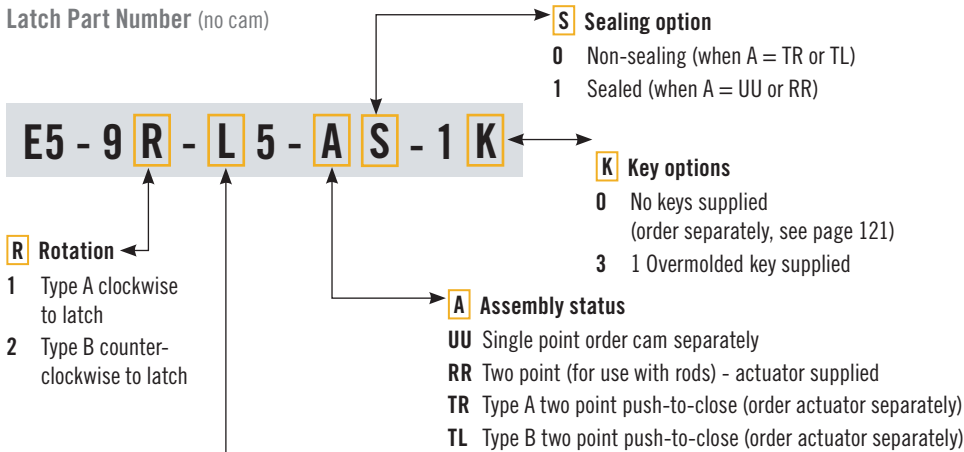

Cam Part Number Table (order separately from latch)

Grip	Part Number	Grip	Part Number
22.7 (.89)	E5-6603	30.7 (1.21)	E5-6607
24.7 (.97)	E5-6604	32.7 (1.29)	E5-6608
26.7 (1.05)	E5-6605	34.7 (1.37)	E5-6609
28.7 (1.13)	E5-6606	36.7 (1.44)	E5-6610

If grip falls between two choices, use the smaller option

**Part Number Selection**

See table

**Single point**

Order latch and cam separately

**Two point (for use with rods)**

Order latch only  
(two point actuator supplied)

**Two point push-to-close action (spring loaded)**

Order latch and actuator separately.  
Actuator part number A5-91-201-11,  
see page 172 for details.  
To be used with *SOUTHCO*® R4  
rotary series latches and cables  
see page 322.





# E5 Cam Latch

Zinc · T-handle · Hand operated · Adjustable grip

- Single hole install
- Multiple key code options
- Easy grip adjustment
- Tool operated for security

## Material and Finish

Zinc alloy, powder coated or chrome plated and steel, zinc plated

## Performance Details

Maximum static load: 330 N (74 lbf)

## Installation Notes

Position cam so latching function can be achieved comfortably by hand. Recommended tightening torque for mounting nut is 10 N·m (88 in·lbf) max, and jam nut is 7 N·m (62 in·lbf)

## Sealing Notes

NEMA 4 / IP65 achieved using gasket supplied

## Keys and Accessories

See page 121 and 169-175

## Part Number Selection

See table

Order latch and cam separately.

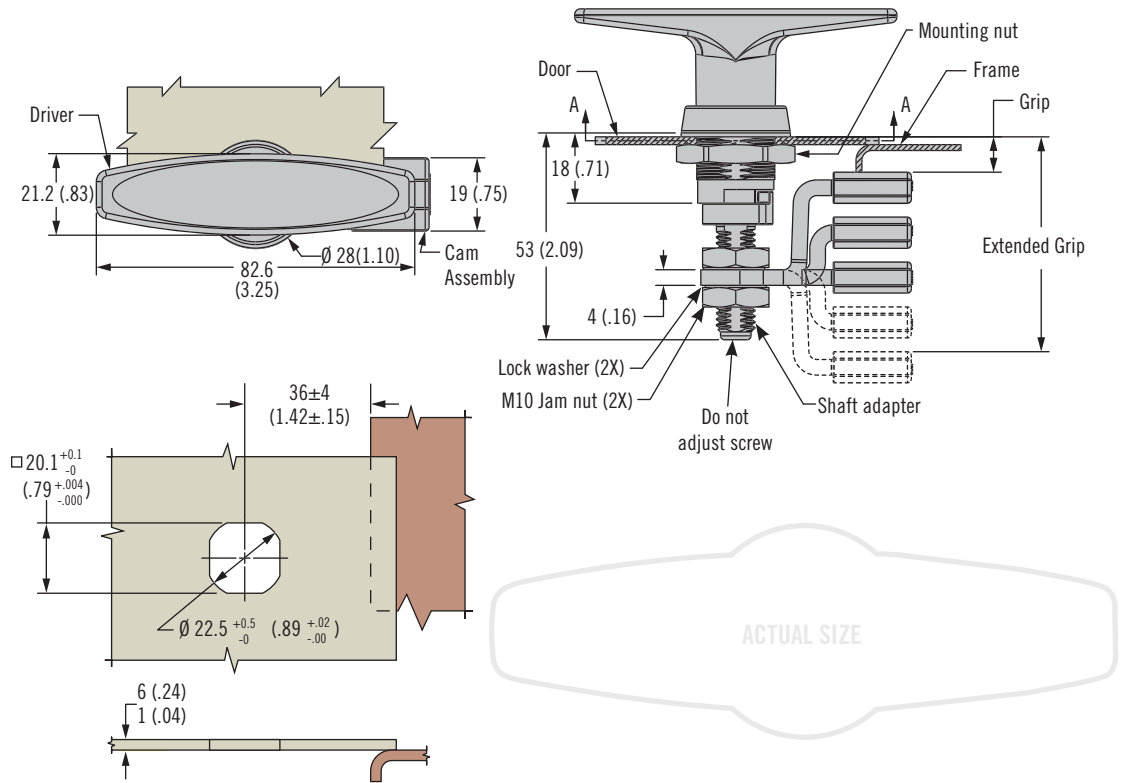

## L Lock Style

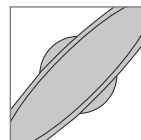

Non-locking

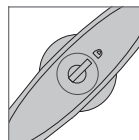

Key-locking  
key code CH751

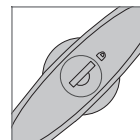

Key-locking  
key code R001  
with shutter

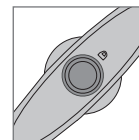

Key-locking  
(order lock core  
separately)

## Part Number

**E5 - 9 - L F - 01 - 1 K**

**F** Finish  
2 Bright chrome  
5 Black powder coated

**L** Lock style

- 60 Non-Locking (omit last two digits of part number)
- 61 Keyed CH751 (lock core finish matches handle finish)
- 62 Keyed R001 (stainless steel scalp shuttered)
- 63 Without lock core (omit last two digits of part number)  
Order lock core separately, see page 190

**K** Key options

- 0 No keys supplied (order separately, See page 121)
- 3 1 Overmolded key supplied

# E5 Cam Latch

Zinc · L-handle · Hand operated · Adjustable grip



165B

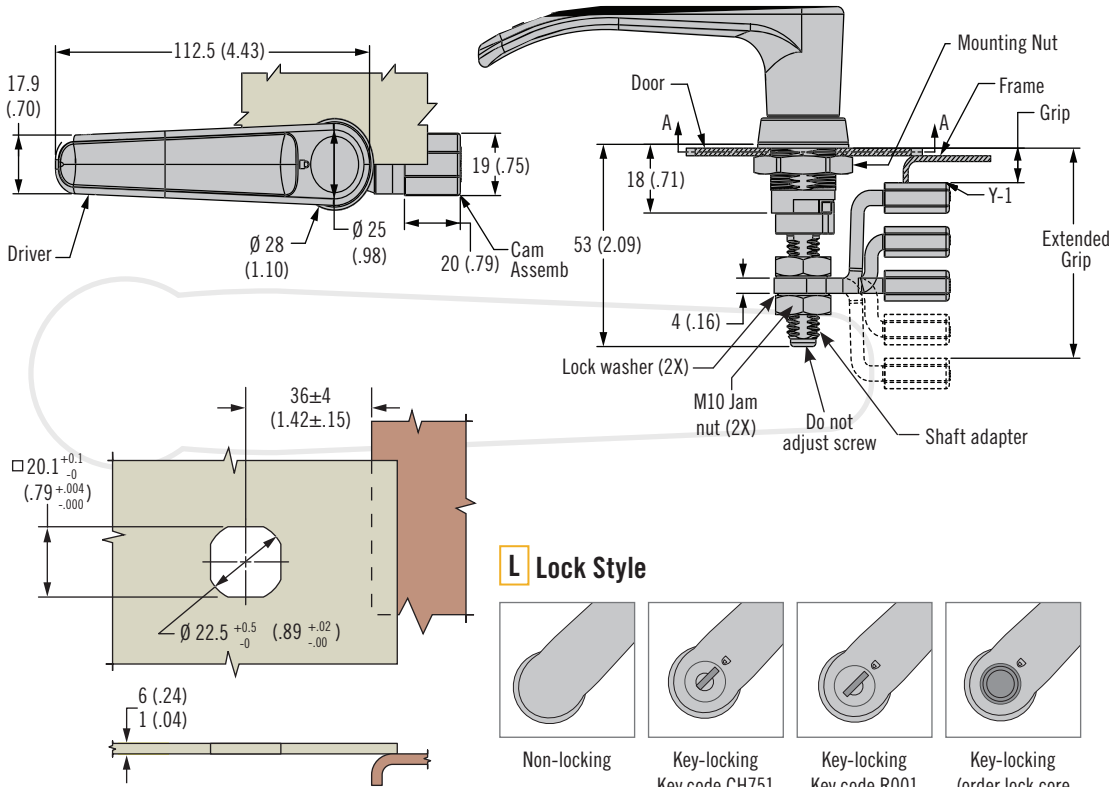

## L Lock Style

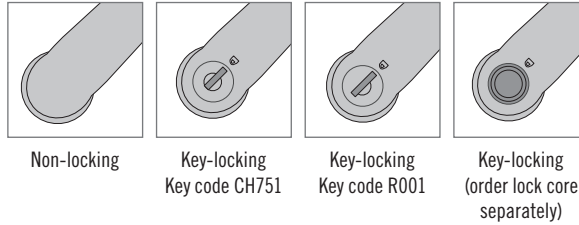

- Single hole install
- Multiple key code options
- Easy grip adjustment
- Tool operated for security

## Material and Finish

Zinc alloy, powder coated or chrome plated and steel, zinc plated

## Performance Details

Maximum static load: 330 N (74 lbf)

## Installation Notes

Position cam so latching function can be achieved comfortably by hand. Recommended tightening torque for mounting nut is 10 N·m (88 in·lbf) max, and jam nut is 7 N·m (62 in·lbf)

## Sealing Notes

NEMA 4 / IP65 achieved using gasket supplied

## Keys and Accessories

See page 121 and 169-175

## Part Number Selection

See table

Order latch and cam separately.

## Part Number

**E5 - 9 - L F - 01 - 1 K**

### L Lock style

- 70 Non-Locking (omit last two digits of part number)
- 71 Keyed 751 (lock core finish matches handle finish)
- 72 Keyed R001 (stainless steel scalp shuttered)
- 73 Without lock core (omit last two digits of part number)

### F Finish

- 2 Bright chrome
- 5 Black powder coated

### K Key options

- 0 No keys supplied (order separately, See page 121)
- 3 1 Overmolded key supplied

Protected Cam Part Number Table (order separately from latch)				
Minimum Grip +2(.08) -0	Maximum Grip +2(.08) -0	Offset	Cam Type	Part Number
5 (.20)	16.5 (.65)	Deep Cam	Forward	E5-4001
51 (2.01)	62.5 (2.46)	Deep Cam	Reversed	
16.5 (.65)	28 (1.10)	Cam	Forward	E5-4002
39.5 (1.56)	51 (2.01)	Cam	Reversed	
28 (1.10)	39.5 (1.56)	-	Straight Cam	E5-4003

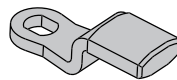

## Protected Cam

- Stable frame engagement
- Improved surface contact
- Minimal frame surface prep

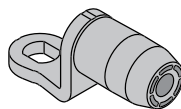

## Roller Cam

- Reduce operating effort
- Minimize scratching frame finish
- Detented feel (with optional Keeper)

Roller Cam Part Number Table (order separately from latch)				
0 (0)	5 (.20)	Extra Deep Cam	Forward	E5-4505
54 (2.13)	62.5 (2.46)	Extra Deep Cam	Reversed	
0 (0)	8 (.31)	Deep Cam	Forward	E5-4506
45 (1.89)	58 (2.28)	Deep Cam	Reversed	
8 (.31)	18 (.71)	Medium Cam	Forward	E5-4507
38 (1.50)	48 (1.89)	Medium Cam	Reversed	
18 (.17)	28 (1.10)	Low Cam	Forward	E5-4508
28 (1.10)	38 (1.50)	Low Cam	Reversed	



# E5 Cam Latch

Zinc · Wing Knob · Hand operated · Adjustable grip

- Single hole install
- Multiple key code options
- Easy grip adjustment
- Tool operated for security

### Material and Finish

Zinc alloy, powder coated or chrome plated and steel, zinc plated

### Performance Details

Maximum static load: 330 N (74 lbf)

### Installation Notes

Position cam so latching function can be achieved comfortably by hand. Recommended tightening torque for mounting nut is 10 N·m (88 in·lbf) max, and jam nut is 7 N·m (62 in·lbf)

### Sealing Notes

NEMA 4 / IP65 achieved using gasket supplied

### Keys and Accessories

See page 121 and 169-175

### Part Number Selection

See table

Order latch and cam separately.

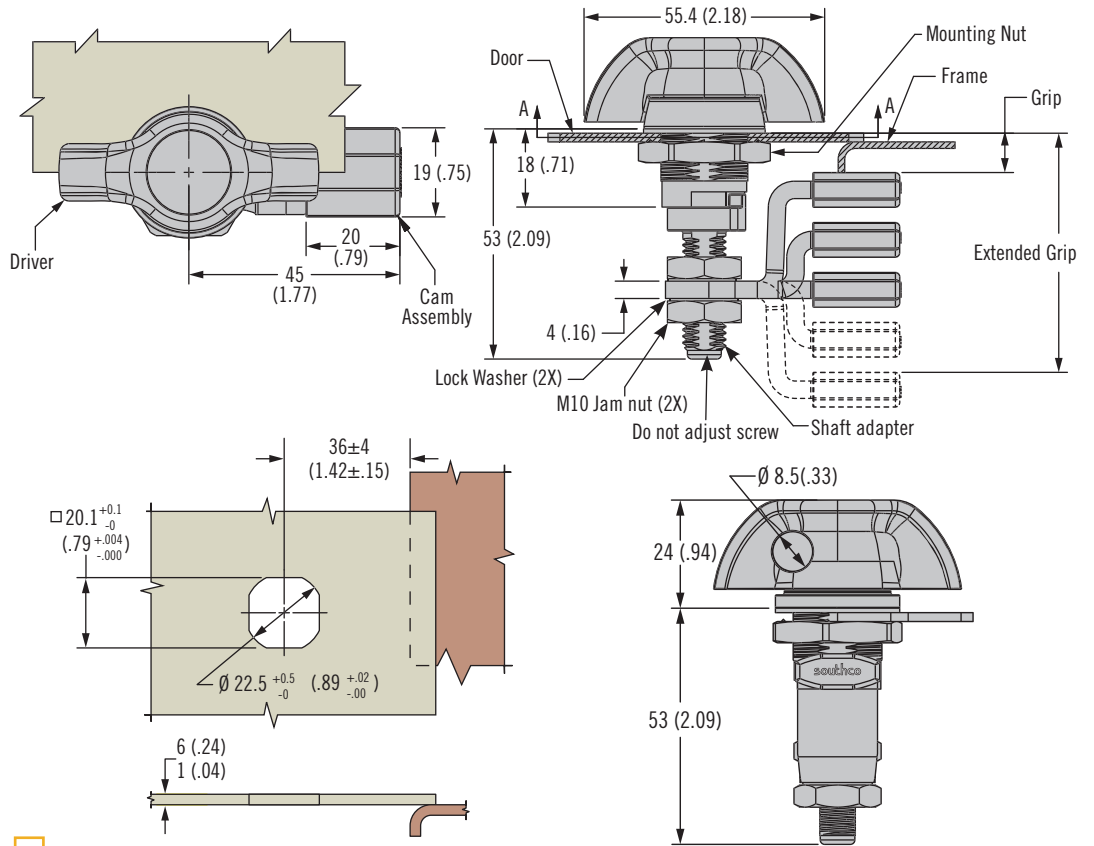

### L Lock Styles

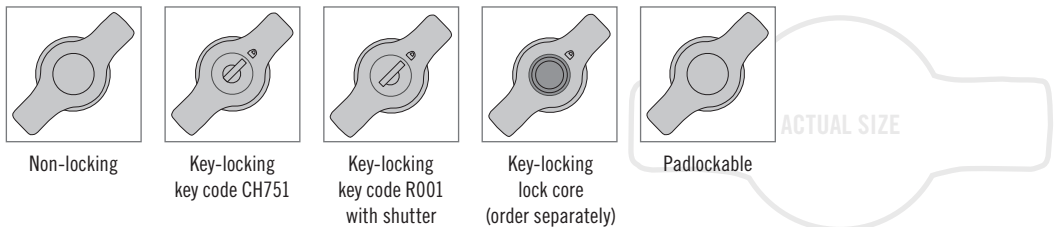

### Part Number

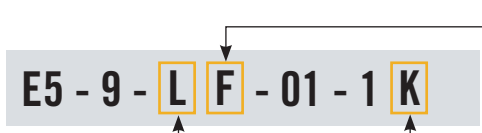

- F Finish**
- 2 Bright chrome (only for padlockable version)
  - 5 Black powder coated

- L Lock style**
- 30 Non-locking (omit last two digits of part number)
  - 31 Key-locking black lock core keyed alike CH751
  - 33 Without lock core (omit last two digits of part number) (order lock core separately, see page 190 except PK-65 heavy duty lock)
  - 34 Key-Locking stainless steel scalp and shuttered lock core keyed alike CH751, PK-65 heavy duty lock
  - 35 Key-Locking stainless steel scalp and shuttered lock core keyed alike R001, PK-65 heavy duty lock
  - 36 Without lock core (omit last two digits of part number), heavy duty lock (order lock core separately, see page 190 for PK-65 only) R001, PK-65 heavy duty lock
  - 51 Padlockable, Type A clockwise to latch (omit last two digits of part number)
  - 52 Padlockable, Type B counter-clockwise to latch (omit last two digits of part number)

- K Key options**
- 0 No keys supplied (order separately, See page 121)
  - 3 1 Overmolded key supplied



# E5 Cam Latch

Zinc · Push-to-close · Hand, key or tool operated · Single and two point

- Single hole installation
- Latched / unlatched indicator
- Push-to-close action

## Material and Finish

Zinc alloy, powder coated and steel, zinc plated

## Performance Details

Maximum static load: 330 N (74 lbf)

## Installation Notes

Mounting nut maximum tightening torque: 10 N·m (88 in·lbf)

Screw Maximum tightening torque: 5 N·m (45 in·lbf) for two point actuator only

## Keys and Accessories

See page 121 and 169-175

## Notes

Single Point: Push-to-close action in unlocked position only and key inserted (cylinder lock)

Two Point: Order actuator separately (see page 172)

For lock core selection and a complete overview of the *SOUTHCO*® Key-Choice System see page 190

## Actuator Part Number

See page 172 for details

Two point to be used with *SOUTHCO*® R4 rotary series latches and cables see page 322

Two point push to close action: Internal spring causes return of driver and actuator to original latched position when driver is released after opening. Ideal for use with cables and rotary latches.

## Single Point Spring-Loaded (Type A tool operated shown)

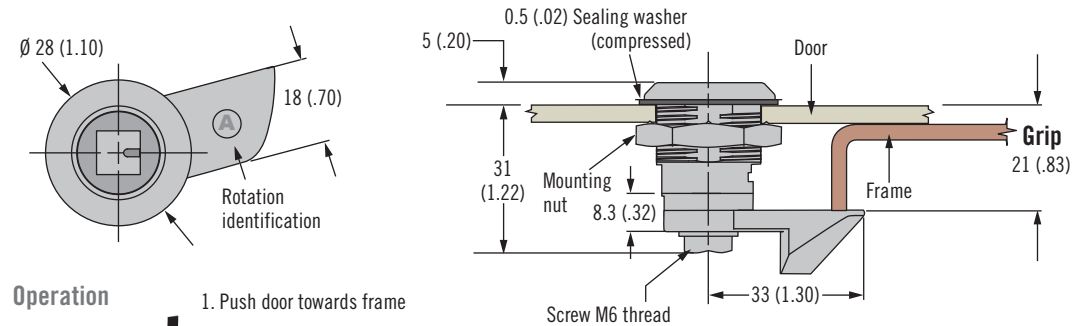

## Operation

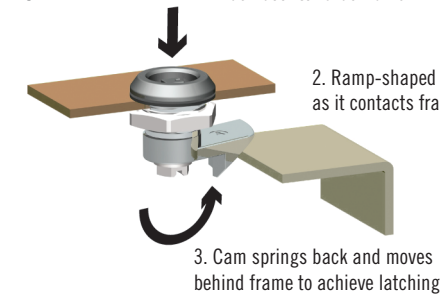

## Rotation

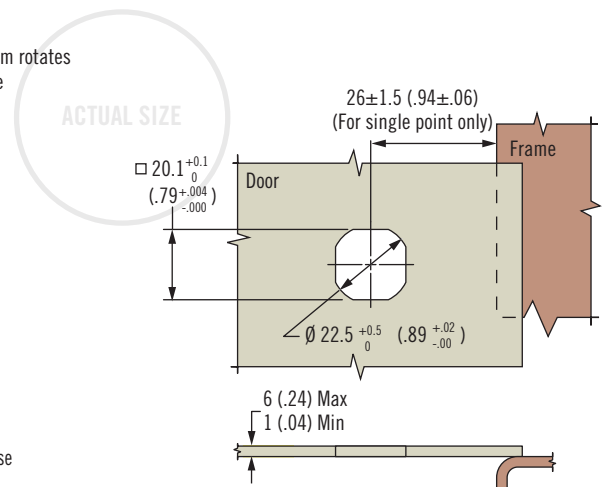
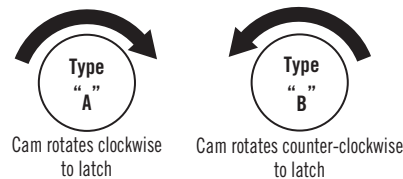

## Two Point Spring-Loaded (Type A hand operated shown)

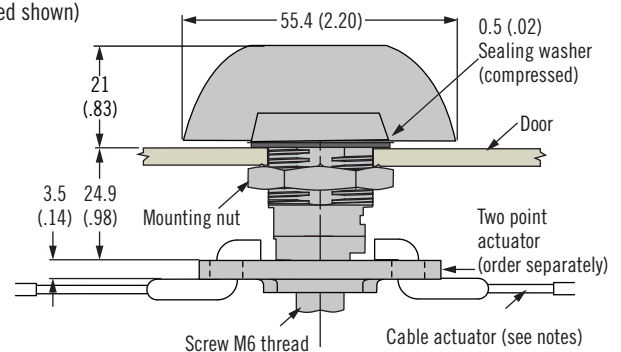
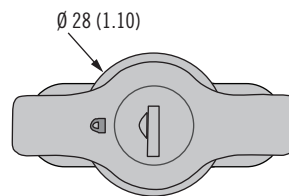

## Two Point Actuator for bare cable

(order separately, see page 173)

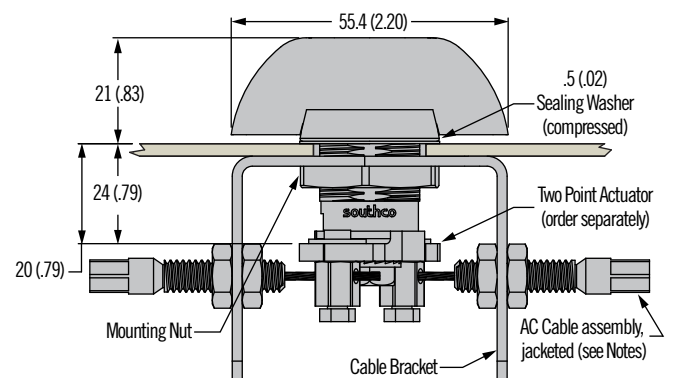

### Hand / Key Operated

- F Finish**
- 2 Bright chrome (not available for wing type)
  - 5 Black powder coated

- T Type**
- 5 Cylinder lock keyed alike CH751
  - 9 Wing / T-handle / L-handle





- R Rotation**
- 51 Type A single point (for visual identification cam stamped A or B)
  - 52 Type B single point (for visual identification cam stamped A or B)
  - TR Type A two point (order actuator separately)
  - TL Type B two point (order actuator separately)

### Part Number Selection

Latch supplied fully assembled

- K Key options**
- 0 No keys supplied (order separately, See page 121)
  - 3 1 Overmolded key supplied

**E5 - T - L F - R 0 - 1 K**

Lock style	T = 5		T = 9	
				
	Cylinder Lock	Wing	T-handle	L-handle
Non-locking (omit last two digits of part number)	~	30	60	70
Keyed CH751 (lock core finish matches handle finish)	~	31	61	71
Keyed CH751 (stainless steel scalp shuttered)	40	~	~	~
Keyed R001 reversible (stainless steel scalp shuttered)	~	32	62	72
Without lock core (omit last two digits of part number) (to be ordered separately see page 190)	~	33	63	73

### Tool Operated

#### H Head Styles

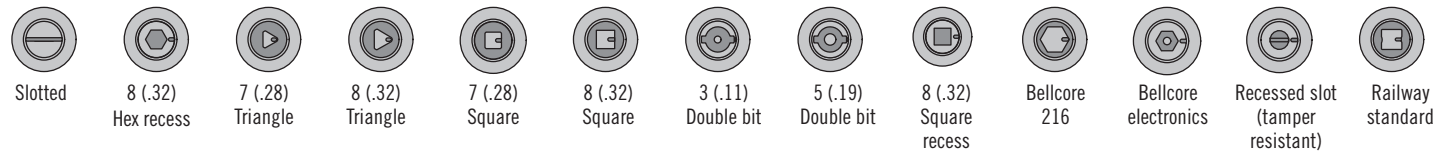

- F Finish**
- 2 Bright chrome
  - 5 Black powder coated

- H Head style**
- 00 Slotted
  - 01 8 (.32) Hex recess
  - 02 7 (.28) Triangle
  - 03 8 (.32) Triangle
  - 04 7 (.28) Square
  - 05 8 (.32) Square
  - 06 3 (.11) Double bit
  - 07 5 (.19) Double bit
  - 08 8 (.32) Square recess
  - 13 Bellcore 216
  - 19 Bellcore electronics
  - 21 Recessed slot (tamper resistant)
  - 22 Railway standard

- R Rotation**
- 51 Type A single point (for visual identification, cam stamped A or B)
  - 52 Type B single point (for visual identification, cam stamped A or B)
  - TR Type A two point (order actuator separately)
  - TL Type B two point (order actuator separately)

### Part Number Selection

Latch supplied fully assembled

**E5 - 6 - H F - R 0**



# E5 Cam Latch

Zinc · Cylinder lock · Fixed grip

- Single hole install
- Latched / unlatched indicator

## Material and Finish

Zinc alloy, powder coated and steel, zinc plated

Scalp stainless steel

## Performance Details

Maximum static load: 330 N (74 lbf)

## Installation Notes

Mounting nut maximum tightening torque: 10 N·m (88 in·lbf)

Screw Maximum tightening torque: 5 N·m (45 in·lbf)

## Sealing Notes

NEMA 4 / IP65 achieved using gasket supplied

## Keys and Accessories

See page 121 and 169-175

## Notes

Suitable for push-to-close action see page 166.

See page 170 for cam part numbers

## Part Number Selection

See table

Order latch and cam separately

## Cylinder Lock

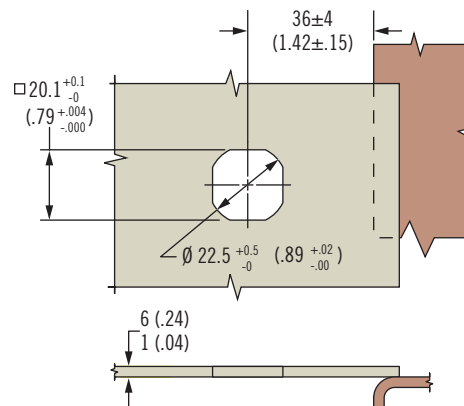
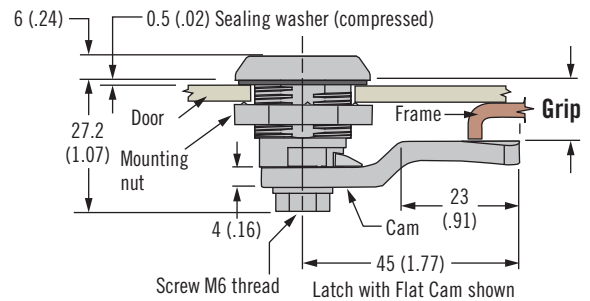
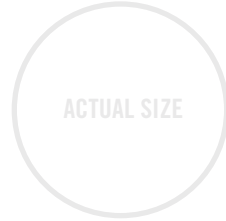
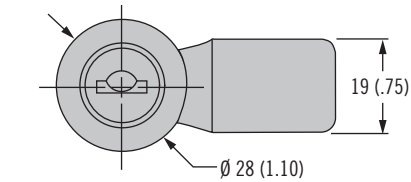

- F** Finish ←
- 2 Bright chrome
  - 5 Black powder coated

**K** Key options CH751

- 0 No keys supplied (order separately, see page 121)
- 2 2 Flat keys supplied

Latch Part Number  
(no cam)

**E5 - 5 - 40 F - UU1 - 1 K**

# E5 Cam Latch Accessories

## Flush Mount Bracket



### Flush Cup

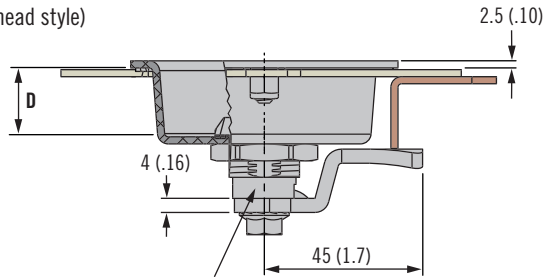
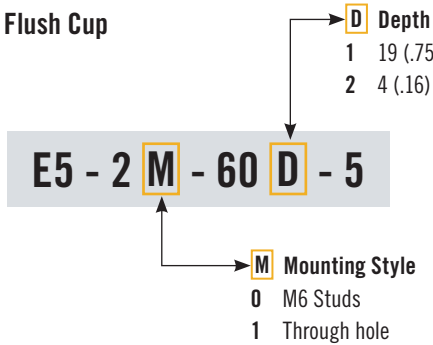

To calculate total grip, add cup depth (D) to latch grip

### Material and Finish

Stainless steel or galvanized steel with rubber o-ring

### Notes

For use with tool operated standard series cam latches, see pages 159, 163-168

See page 117 for additional dimensions

### Flush Mount Bracket

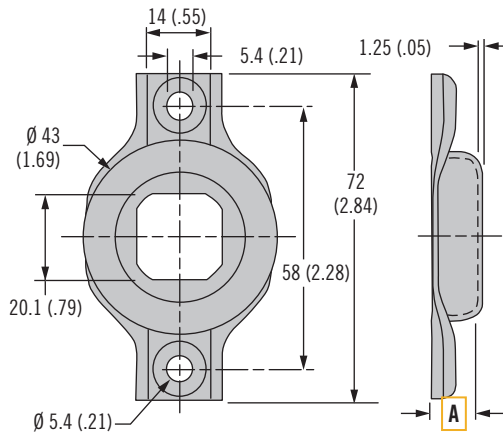
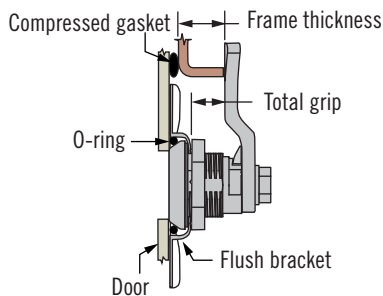

To calculate the **Total Grip**, use the following formula: **Frame Thickness + Compressed Gasket - A**. Use this **Total Grip** with the appropriate E5 tables in the *SOUTHCO*® Handbook to determine cam type.

A	Part Number	Material
6.6	E5-77-1-12	Galvanized steel
6.6	E5-77-1-24	304 Stainless steel



# E5 Cam Latch Accessories

## Cams

### Material and Finish

Standard cam: steel

Protected cam: steel, nylon

Roller cam: steel, nylon

### Installation Notes

- Install cam to latch assembly. Properly orient for rotation & grip
- Install screw. Tighten to 5 N-m (44 in-lbf) MAX

### Part Number Selection

See table for cam part number  
Order latch and cam separately  
For latch part number, see pages  
154-155

### Cam Options

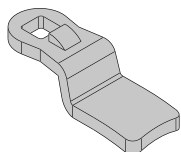

#### Standard Cam

- Stable frame engagement
- Improved surface contact
- Minimal frame surface prep



#### Protected Cam

- Stable frame engagement
- Minimize scratching frame finish
- Minimal frame surface prep

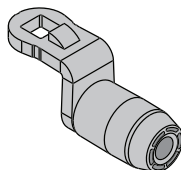

#### Roller Cam

- Reduce operating effort
- Minimize scratching frame finish
- Detented feel (with optional Keeper)



#### Optional Keeper for Roller Cam

Part number E5-74-601-33

### Short Housing Table

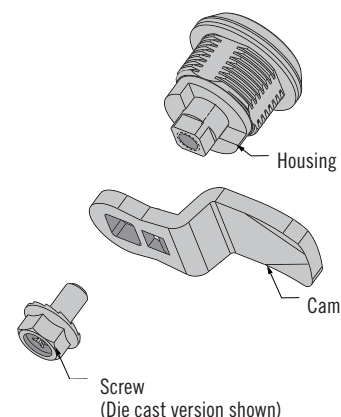
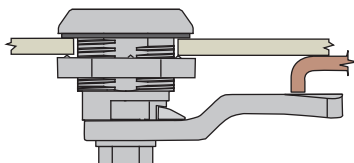

Cam Part Number Table (order separately from latch)							
Grip +2(.08) -0(.00)	Standard Cam Part Number	Protected Cam Part Number	Roller Cam Part Number	Grip +2(.08) -0(.00)	Standard Cam Part Number	Protected Cam Part Number	Roller Cam Part Number
4 (.16)	E5-6003	E5-6003-P	-	14 (.55)	E5-6008	E5-6008-P	-
6 (.24)	E5-6004	E5-6004-P	-	16 (.63)	E5-6009	E5-6009-P	E5-7009
8 (.31)	E5-6005	E5-6005-P	-	18 (.71)	E5-6010	E5-6010-P	E5-7010
10 (.39)	E5-6006	E5-6006-P	-	20 (.79)	E5-6011	E5-6011-P	E5-7011
12 (.47)	E5-6007	E5-6007-P	-	22 (.87)	E5-6012	E5-6012-P	E5-7012

Cam Part Number Table (order separately from latch)							
Grip +2(.08) -0(.00)	Standard Cam Part Number	Protected Cam Part Number	Roller Cam Part Number	Grip +2(.08) -0(.00)	Standard Cam Part Number	Protected Cam Part Number	Roller Cam Part Number
24 (.94)	E5-6013	E5-6013-P	E5-7013	34 (1.34)	E5-6018	E5-6018-P	E5-7018
26 (1.02)	E5-6014	E5-6014-P	E5-6014	36 (1.42)	E5-6019	E5-6019-P	E5-7019
28 (1.10)	E5-6015	E5-6015-P	E5-7015	38 (1.50)	E5-6020	E5-6020-P	E5-7020
30 (1.18)	E5-6016	E5-6016-P	E5-7016	40 (1.57)	E5-6021	E5-6021-P	E5-7021
32 (1.25)	E5-6017	E5-6017-P	E5-7017	42 (1.65)	E5-6022	E5-6022-P	E5-7022

If grip falls between two choices, use the smaller options

Dimensions in millimeters (inch) unless otherwise stated

# E5 Cam Latch Accessories

## Cams

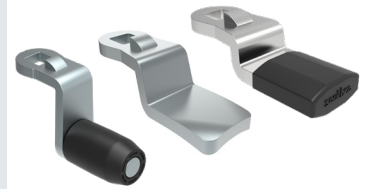

### Long Housing Table

**E5 - 6A - H F - UU D**

D	Door Thickness	Grip Range
1	1-18 (.04-.71)	5-53 (.20-2.09)
2	1-18 (.04-.71)	54-82 (2.13-3.23)

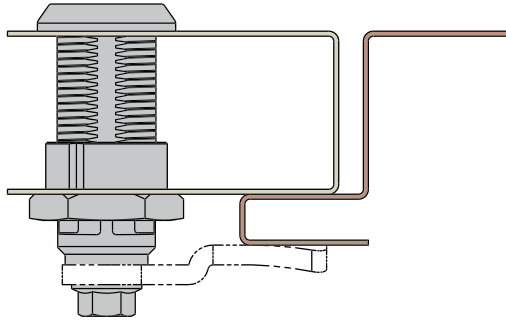

### Material and Finish

Standard cam: steel  
 Protected cam: steel, nylon  
 Roller cam: steel, nylon

Cam Part Number Table (order separately from latch)				
D	Grip +2 (.08) -0 (.00)	Standard Cam Part Number	Protected Cam Part Number	Roller Cam Part Number
1	5 (.2)	E5-6028	E5-6028-P	-
	7 (.28)	E5-6027	E5-6027-P	-
	9 (.35)	E5-6026	E5-6026-P	-
	11 (.43)	E5-6025	E5-6025-P	-
	13 (.51)	E5-6024	E5-6024-P	-
	15 (.59)	E5-6023	E5-6023-P	-
	17 (.67)	E5-6001	E5-6001-P	-
	19 (.75)	E5-6002	E5-6002-P	-
	21 (.83)	E5-6003	E5-6003-P	-
	23 (.91)	E5-6004	E5-6004-P	-
	25 (.98)	E5-6005	E5-6005-P	-
	27 (1.06)	E5-6006	E5-6006-P	-
	29 (1.14)	E5-6007	E5-6007-P	-
	31 (1.22)	E5-6008	E5-6008-P	-
	33 (1.3)	E5-6009	E5-6009-P	E5-7009
	35 (1.38)	E5-6010	E5-6010-P	E5-7010
	37 (1.46)	E5-6011	E5-6011-P	E5-7011
	39 (1.54)	E5-6012	E5-6012-P	E5-7012
	41 (1.61)	E5-6013	E5-6013-P	E5-7013
	43 (1.69)	E5-6014	E5-6014-P	E5-7014
45 (1.77)	E5-6015	E5-6015-P	E5-7015	
45 (1.77)	E5-6015	E5-6015-P	E5-7015	
45 (1.77)	E5-6015	E5-6015-P	E5-7015	
45 (1.77)	E5-6015	E5-6015-P	E5-7015	
53 (3.07)	E5-6019	E5-6019-P	E5-7019	

Cam Part Number Table (order separately from latch)				
D	Grip +2 (.08) -0 (.00)	Standard Cam Part Number	Protected Cam Part Number	Roller Cam Part Number
2	54 (2.13)	E5-6108	E5-6108-P	-
	56 (2.2)	E5-6109	E5-6109-P	E5-7109
	58 (2.28)	E5-6110	E5-6110-P	E5-7110
	60 (2.36)	E5-6111	E5-6111-P	E5-7111
	62 (2.44)	E5-6112	E5-6112-P	E5-7112
	64 (2.52)	E5-6113	E5-6113-P	E5-7113
	66 (2.6)	E5-6114	E5-6114-P	E5-7114
	68 (2.68)	E5-6115	E5-6115-P	E5-7115
	70 (2.76)	E5-6116	E5-6116-P	E5-7116
	72 (2.83)	E5-6117	E5-6117-P	E5-7117
	74 (2.91)	E5-6118	E5-6118-P	E5-7118
	76 (2.99)	E5-6119	E5-6119-P	E5-7119
	78 (3.07)	E5-6120	E5-6120-P	E5-7120
	80 (3.15)	E5-6121	E5-6121-P	E5-7121
	82 (3.23)	E5-6122	E5-6122-P	E5-7122

### Part Number Selection

See table for cam part number  
 Order latch and cam separately  
 For latch part number, see pages  
 154-155

If grip falls between two choices, use the smaller options





# E5 Cam Latch Accessories

## Cams

### Material and Finish

Standard cam: steel  
 Protected cam: steel, nylon  
 Roller cam: steel, nylon

### Part Number Selection

See table for cam part number  
 Order latch and cam separately  
 For latch part number, see pages  
 154-155

### Long Housing Table



D	Door Thickness	Grip Range
3	18-33 (.71-1.30)	18-66 (.71-2.60)
4	18-33 (.71-1.30)	68-82 (2.60-3.23)
5	33-51 (1.30-2.00)	34-82 (1.34-3.23)

Cam Part Number Table (order separately from latch)				
D	Grip +2 (.08) -0 (.00)	Standard Cam Part Number	Protected Cam Part Number	Roller Cam Part Number
3	18 (.71)	E5-6128	E5-6123-P	E5-7118
	20 (.79)	E5-6127	E5-6122-P	E5-7117
	22 (.87)	E5-6126	E5-6121-P	E5-7116
	24 (.94)	E5-6125	E5-6120-P	E5-7115
	26 (1.02i)	E5-6124	E5-6119-P	E5-7114
	28 (1.1)	E5-6123	E5-6123-P	E5-7113
	30 (1.18)	E5-6101	E5-6117-P	E5-7112
	32 (1.26)	E5-6102	E5-6116-P	E5-7111
	34 (1.34)	E5-6103	E5-6115-P	E5-7110
	36 (1.42)	E5-6104	E5-6114-P	E5-7109
	38 (1.5)	E5-6105	E5-6113-P	-
	40 (1.57)	E5-6106	E5-6112-P	-
	42 (1.65)	E5-6107	E5-6111-P	-
	44 (1.73)	E5-6108	E5-6110-P	-
	46 (1.81)	E5-6109	E5-6109-P	-
	48 (1.89)	E5-6110	E5-6110-P	E5-7010
	50 (1.97)	E5-6111	E5-6111-P	E5-7011
	52 (2.05)	E5-6112	E5-6112-P	E5-7012
	54 (2.13)	E5-6113	E5-6113-P	E5-7013
	56 (2.2)	E5-6114	E5-6114-P	E5-7014
58 (2.28)	E5-6115	E5-6115-P	E5-7015	
60 (2.36)	E5-6116	E5-6116-P	E5-7016	
62 (2.44)	E5-6117	E5-6117-P	E5-7017	
64 (2.52)	E5-6118	E5-6118-P	E75-7018	
66 (2.6)	E5-6119	E5-6119-P	E5-7019	

Cam Part Number Table (order separately from latch)				
D	Grip +2 (.08) -0 (.00)	Standard Cam Part Number	Protected Cam Part Number	Roller Cam Part Number
4	66 (2.6)	E5-6114	E5-7114	
	68 (2.68)	E5-6115	E5-7115	
	70 (2.76)	E5-6116	E5-7116	
	72 (2.83)	E5-6117	E5-7117	
	74 (2.91)	E5-6118	E5-7118	
	76 (2.99)	E5-6119	E5-7119	
	78 (3.07)	E5-6120	E5-7120	
	80 (3.15)	E5-6121	E5-7121	
	82 (3.23)	E5-6122	E5-7122	

Cam Part Number Table (order separately from latch)				
D	Grip +2 (.08) -0 (.00)	Standard Cam Part Number	Protected Cam Part Number	Roller Cam Part Number
5	34 (1.34)	E5-6125	E5-6120-P	E5-7115
	36 (1.42)	E5-6124	E5-6119-P	E5-7114
	38 (1.5)	E5-6123	E5-6123-P	E5-7113
	40 (1.57)	E5-6101	E5-6117-P	E5-7112
	42 (1.65)	E5-6102	E5-6116-P	E5-7111
	44 (1.73)	E5-6103	E5-6115-P	E5-7110
	46 (1.81)	E5-6104	E5-6114-P	E5-7109
	48 (1.89)	E5-6105	E5-6113-P	-
	50 (1.97)	E5-6106	E5-6112-P	-
	52 (2.05)	E5-6107	E5-6111-P	-
	54 (2.13)	E5-6108	E5-6110-P	-
	56 (2.2)	E5-6109	E5-6109-P	E5-7109
	58 (2.28)	E5-6110	E5-6110-P	E5-7110
	60 (2.36)	E5-6111	E5-6111-P	E5-7111
	62 (2.44)	E5-6112	E5-6112-P	E5-7112
	64 (2.52)	E5-6113	E5-6113-P	E5-7113
	66 (2.6)	E5-6114	E5-6114-P	E5-7114
	68 (2.68)	E5-6115	E5-6115-P	E5-7115
	70 (2.76)	E5-6116	E5-6116-P	E5-7116
	72 (2.83)	E5-6117	E5-6117-P	E5-7117
74 (2.91)	E5-6118	E5-6118-P	E5-7118	
76 (2.99)	E5-6119	E5-6119-P	E5-7119	
78 (3.07)	E5-6120	E5-6120-P	E5-7120	
80 (3.15)	E5-6121	E5-6121-P	E5-7121	
82 (3.23)	E5-6122	E5-6122-P	E5-7122	



# E5 Cam Latch Accessories

## Multi-point actuators · Dummy cam

### Material and Finish

Zinc alloy

### Notes

Actuator plate (for multi-point see page 322 for cable assembly)  
(Not recommended for Cylinder Lock version)

Not to be used with low profile E5

### Multi-Point Actuator

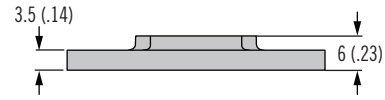
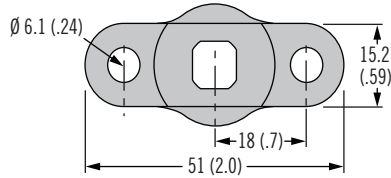

### Part Number

A5-91-201-11

### Material and Finish

Steel, plated

### Notes

Actuator plate (for multi-point see pages 230-231 for rods)

For use with all E5 latches

### Multi-Point Actuator - Low Profile

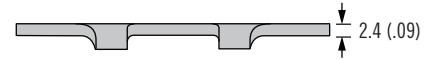
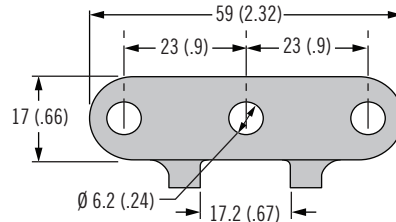

### Part Number

A8-4-01-03

### Material and Finish

Zinc alloy and steel, zinc plated

### Notes

Actuator plate (for multi-point see page 230 for rods)

Not to be used with low profile E5

### Multi-Point Actuator

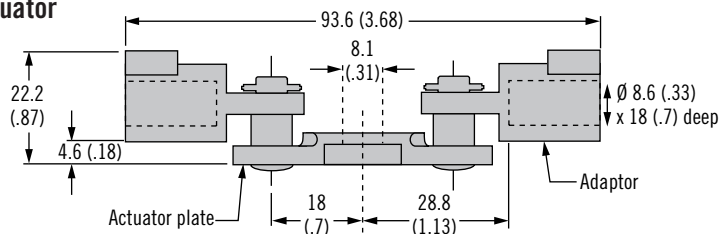

### Part Number

A5-90-101-11

### Material and Finish

Steel, stainless steel

### Notes

Replaces cam when used with actuator plate A5-90-101-11 in order to create a 2-point latching system

### Dummy Cam

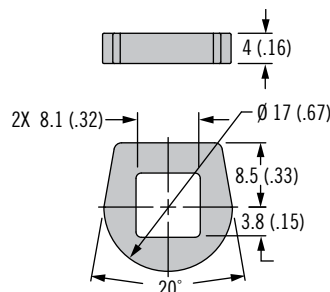

### Part Number

Steel

H3-0-45688

Stainless Steel

H3-0-45688-24

# E5 Cam Latch Accessories

Hooked cam · Multi-point actuator · Cable brackets



## Hooked Cam

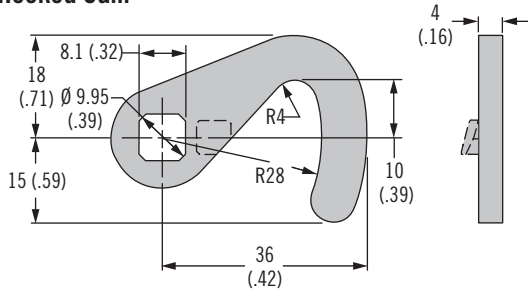

Hooked Cam Part Number	
E5-6200	No stop
E5-6210	Stop for clockwise rotation
E5-6220	Stop for counter-clockwise rotation

## Multi-Point Actuator

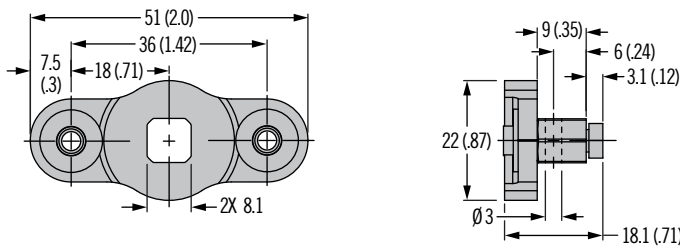

Part Number
A5-99-136

## Cable Bracket – Counter Clockwise Rotation

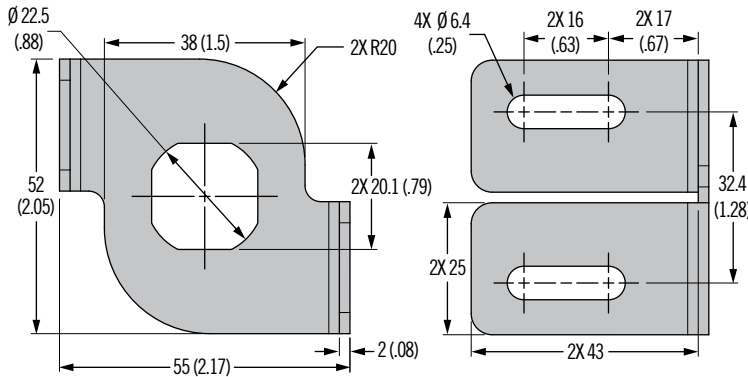

Part Number
AC-0-49617-11-L

## Cable Bracket – Clockwise Rotation

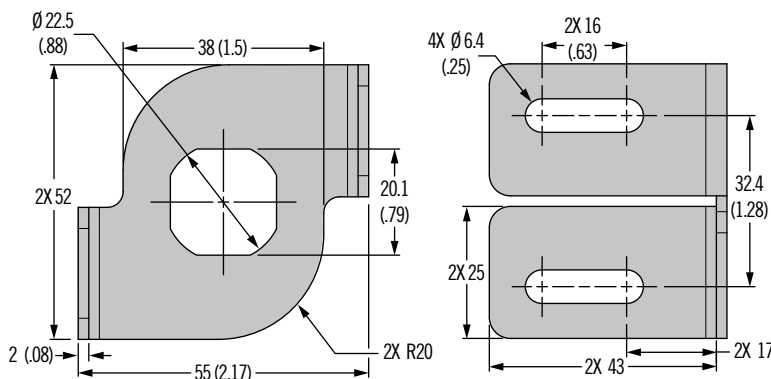

Part Number
AC-0-49617-11-R

## Material and Finish

Steel plated  
 Hook cam: Steel, plated  
 Multi-point actuator: Zinc alloy, plated  
 Cable bracket: Steel, plated

## Notes

Not to be used with low profile E5

## Notes

Use Type B latch with bracket ending in -L and Type A with bracket ending in -R

## Part Number

See table

## Notes

See page 322 for additional cable assembly selections



# E5 Cam Latch and E9 Compression Latch Accessories

## Pull tab · Padlock bracket

### Material and Finish

Padlock bracket: Stainless steel,  
black powder coated

Pull tab: Nylon, black

### Installation Notes

To provide sealing: use two sealing washers and add compressed thickness of each washer and accessory thickness to your **door thickness range**.

### Notes

Padlock brackets and pull tabs for use with E9 or tool operated and cylinder lock E5.

### Part Number

See table

### Padlock Bracket (Square)

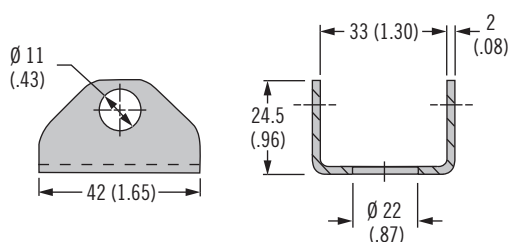

### Padlock Bracket (Round)

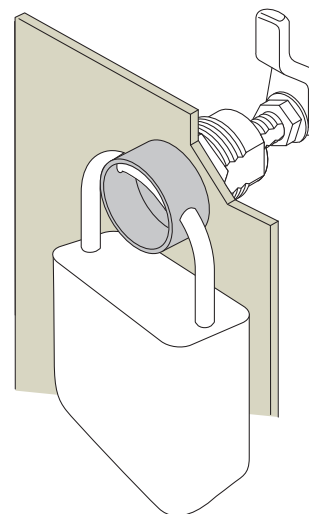
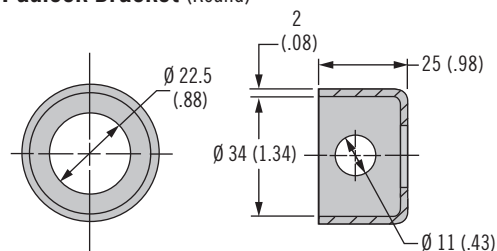

### Pull Tab

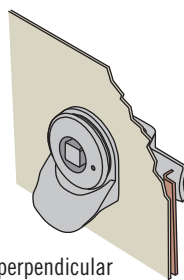
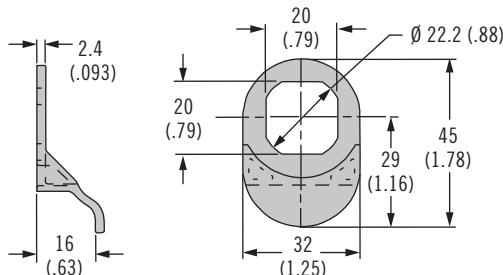

Shown perpendicular  
to latch cam

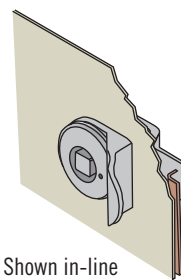

Shown in-line  
with latch cam

Type	Part Number	Grip Adjustment Formula
Padlock bracket square	E3-77-101-31	Add 2 (.08) to door thickness
Padlock bracket round	E3-77-102-31	Add 2 (.08) to door thickness
Pull tab	E5-18	Add 2.4 (.093) to door thickness

# E5 Cam Latch and E9 Compression Latch Accessories

## Sealing cover · Sealing washer



### Sealing Washer

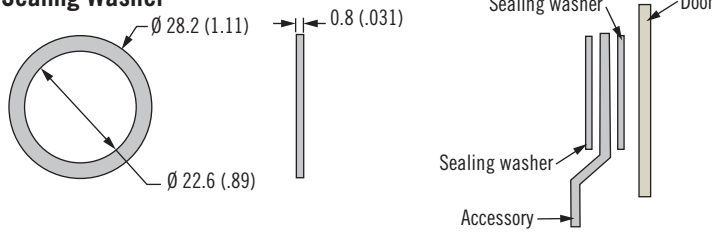

### Sealing Cover - Plastic

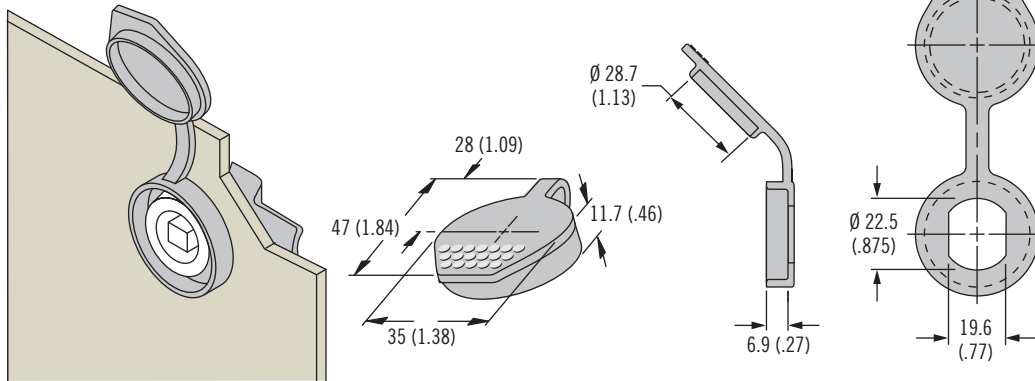

### Bi-Stable Sealing Cover - Stainless Steel

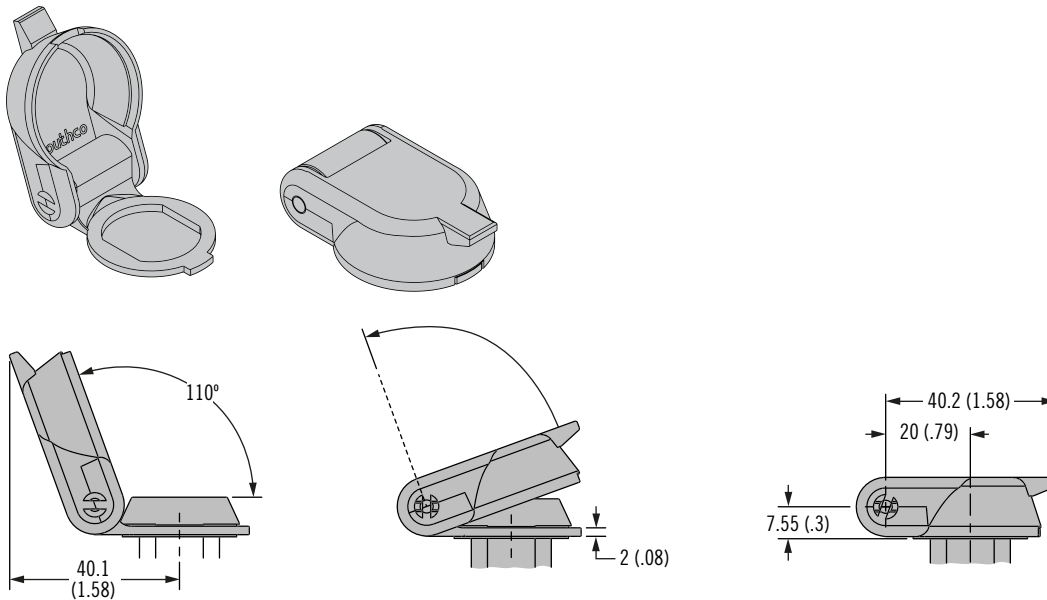

### Material and Finish

Sealing washer: Neoprene natural  
 Sealing cover: Thermoplastic elastomer, black or stainless steel, electropolished

### Installation Notes

To provide sealing: use two sealing washers and add compressed thickness of each washer and accessory thickness to your door thickness range.

### Notes

Sealing washer for use with all E5 and E9 products  
 Sealing cover for use with E9 or tool operated and cylinder lock E5

### Part Number

See table

Type	Part Number	Grip Adjustment Formula
Sealing Washer	E5-17	Add 0.4 (.02) compressed height to door thickness
Sealing Cover – Plastic	90-3	Add 2.3 (.090) to door thickness
Bi-Stable Sealing Cover – Stainless Steel	E3-80-262-40	Add 2.0 (0.8) to door thickness