

Product data sheet

Specifications

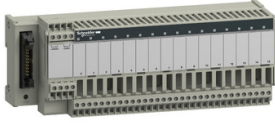

sub-base - soldered solid state output relay ABE7 - 16 inputs - 115 V AC

ABE7S16E2F0

Product availability: Non-Stock - Not normally stocked in distribution facility

Main

Range of Product	Modicon ABE7
Product or Component Type	Solid state input relay sub-base
[Us] rated supply voltage	110/130 V AC 50/60 Hz sensor end) 24 V DC PLC end)
Number of channels	16
Number of terminal per channel	2
Connections - terminals	Screw type terminals, 1 x 0.09...1 x 1.5 mm ² , 0.0001...0.002 in ² (0.09...1.5 mm ²) AWG 28...AWG 16) flexible with cable end Screw type terminals, 1 x 0.14...1 x 2.5 mm ² , 0.0002...0.004 in ² (0.14...2.5 mm ²) AWG 26...AWG 12) solid Screw type terminals, 1 x 0.14...1 x 2.5 mm ² , 0.0002...0.004 in ² (0.14...2.5 mm ²) AWG 26...AWG 14) flexible without cable end Screw type terminals, 2 x 0.09...2 x 0.75 mm ² , 0.0001...0.001 in ² (0.09...0.75 mm ²) AWG 28...AWG 20) flexible with cable end Screw type terminals, 2 x 0.2...2 x 2.5 mm ² , 0.0003...0.004 in ² (0.2...2.5 mm ²) AWG 24...AWG 14) solid

Complementary

Terminal block type	Removable
Supply voltage limits	19...30 V DC PLC end) IEC 61131-2
Isolation PLC/operative part	Yes
Protection type	Internal fuse 1 A 5 x 20 mm fast blow PLC end Adjustable by external fuse fast blow sensor end
Fixing mode	By clips (35 mm symmetrical DIN rail) By screws (solid plate with fixing kit)
Current per channel	0.0083 A
Current state 1 guaranteed	>= 5 mA sensor end)
Voltage state 1 guaranteed	>= 79 V sensor end
Maximum switching current	15 mA PLC end)
Minimum switching current	1 mA for PLC end
Response time	<= 20 ms from state 0 to 1 <= 20 ms from state 1 to 0
Switching frequency	<= 25 Hz 50 %
[Uimp] rated impulse withstand voltage	2.5 kV IEC 60947-1
[Ui] Rated Insulation Voltage	2000 V
Installation category	II IEC 60664-1
Tightening torque	5.3 lbf.in (0.6 N.m) flat Ø 3.5 mm
Width	8.1 in (206 mm)

Price is "List Price" and may be subject to a trade discount – check with your local distributor or retailer for actual price.

Height	3.03 in (77 mm)
Depth	2.3 in (58 mm)
Product Weight	0.875 lb(US) (0.397 kg)

Environment

Dielectric strength	2000 V 50/60 Hz IEC 60947-1
Product Certifications	UL GL DNV CSA EAC
Standards	IEC 61131-2 Type 1
IP degree of protection	IP2X conforming to IEC 60529
Resistance to incandescent wire	1382 °F (750 °C) IEC 60695-2-11
Shock resistance	15 gn 11 ms IEC 60068-2-27
Vibration resistance	2 gn (f= 10...150 Hz) conforming to IEC 60068-2-6
Resistance to electrostatic discharge	4 kV contact) level 3 IEC 61000-4-2 8 kV air) level 3 IEC 61000-4-2
Resistance to radiated fields	9.1 V/m (10 V/m) 26000000...1000000000 Hz)IEC 61000-4-3 level 3
Resistance to fast transients	2 kV level 3 IEC 61000-4-4
Ambient air temperature for operation	23...140 °F (-5...60 °C) IEC 61131-2
Ambient air temperature for storage	-40...176 °F (-40...80 °C) IEC 61131-2
Pollution degree	2 IEC 60664-1

Ordering and shipping details

Category	US10CP222375
Discount Schedule	0CP2
GTIN	3389110546279
Returnability	No
Country of origin	LV

Packing Units

Unit Type of Package 1	PCE
Nbr. of units in pkg.	1
Package 1 Height	2.756 in (7.000 cm)
Package 1 Width	3.228 in (8.200 cm)
Package 1 Length	8.346 in (21.200 cm)
Package weight(Lbs)	17.002 oz (482.000 g)
Unit Type of Package 2	S03
Number of Units in Package 2	16
Package 2 Height	11.811 in (30.000 cm)
Package 2 Width	11.811 in (30.000 cm)
Package 2 Length	15.748 in (40.000 cm)
Package 2 Weight	17.842 lb(US) (8.093 kg)

Contractual warranty

Warranty (in months)

18



Environmental Data

Schneider Electric aims to achieve Net Zero status by 2050 through supply chain partnerships, lower impact materials, and circularity via our ongoing “Use Better, Use Longer, Use Again” campaign to extend product lifetimes and recyclability.

[Environmental Data explained >](#)

[How we assess product sustainability >](#)



Environmental footprint

Total lifecycle Carbon footprint	63 kg CO2 eq.
Carbon footprint of the manufacturing phase [A1 to A3]	14 kg CO2 eq.
Carbon footprint of the distribution phase [A4]	0.1 kg CO2 eq.
Carbon footprint of the installation phase [A5]	0.1 kg CO2 eq.
Carbon footprint of the use phase [B2, B3, B4, B6]	49 kg CO2 eq.
Carbon footprint of the end-of-life phase [C1 to C4]	1 kg CO2 eq.

Use Better



Materials and Substances

Packaging made with recycled cardboard	Yes
Packaging without single use plastic	Yes
SCIP Number	1bbe7d20-74c0-4e7e-b98b-d2946f4ab8b4
EU RoHS Directive	Compliant By Exemption
REACH Regulation	Reference contains Substances of Very High Concern above the threshold
California proposition 65	WARNING: This product can expose you to chemicals including: Lead and lead compounds, which is known to the State of California to cause cancer and birth defects or other reproductive harm. For more information go to www.P65Warnings.ca.gov

Use Longer



Lifetime extension

Repair	No
--------	----

Use Again



Repack and remanufacture

Recyclability potential, in %	6
Circularity Profile	End of Life Information
Take-back	No
WEEE Label	 The product must be disposed on European Union markets following specific waste collection and never end up in rubbish bins.

Dimensions Drawings

Dimensions

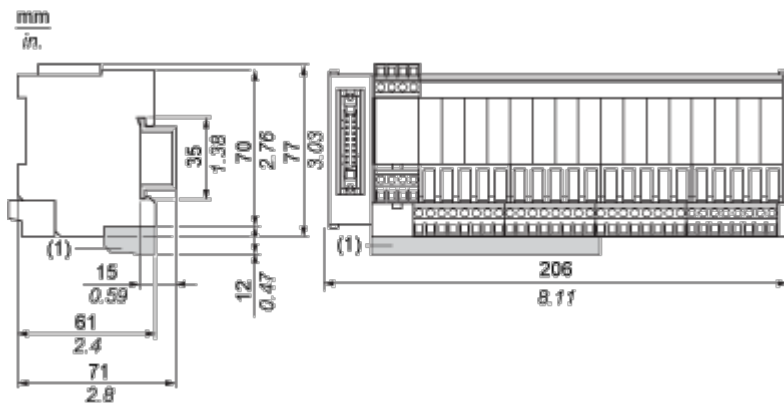

(1) ABE7BV20 / ABE7BV20E

Mounting and Clearance

Mounting

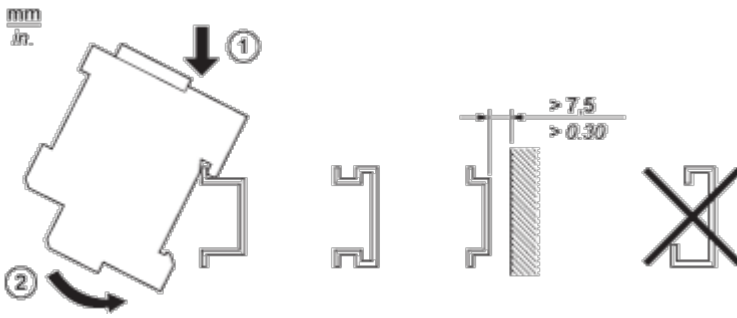

Connections and Schema

HE10 16 Channels

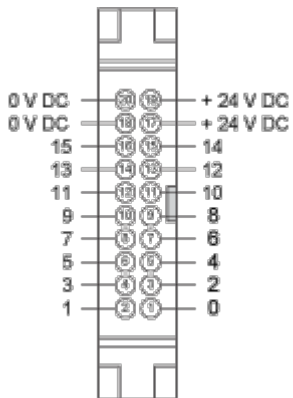

Wiring Diagram

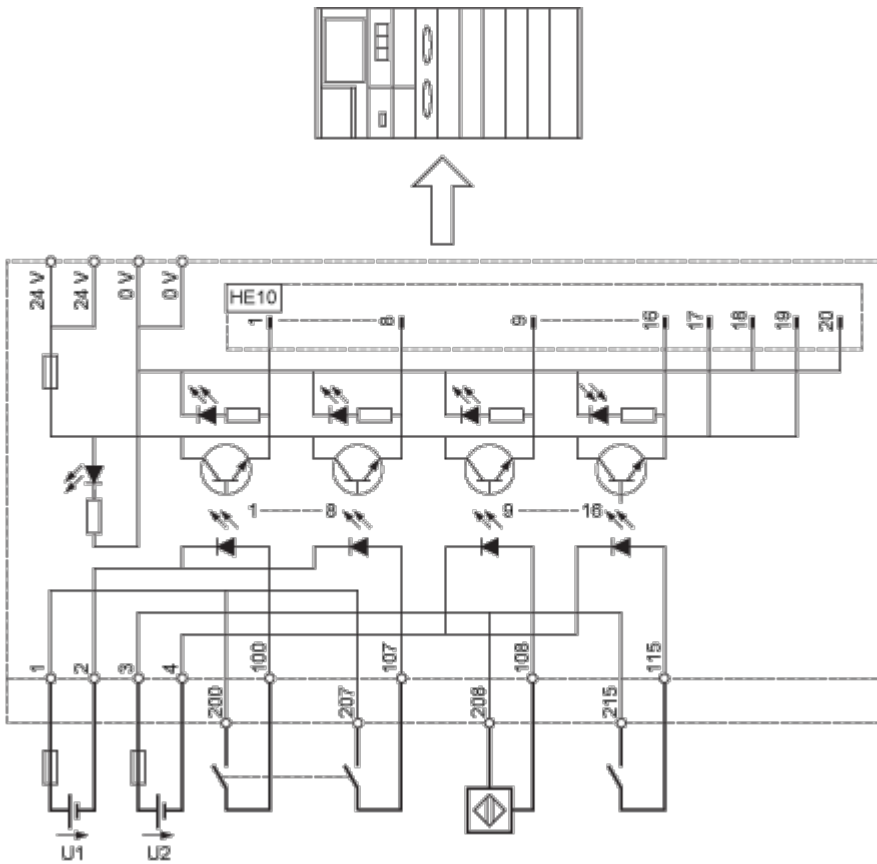

ABE7	U1, U2
S16E2B1 / E2B1E	24 VDC
S16E2E1 / E2E1E	48 VDC
S16E2E0 / E2E0E	48 VAC
S16E2F0 / E2F0E	115 VAC
S16E2M0 / E2M0E	230 VAC

Performance Curves

Curves for Determining Cable Type and Length According to the Current

16-channel Sub-base

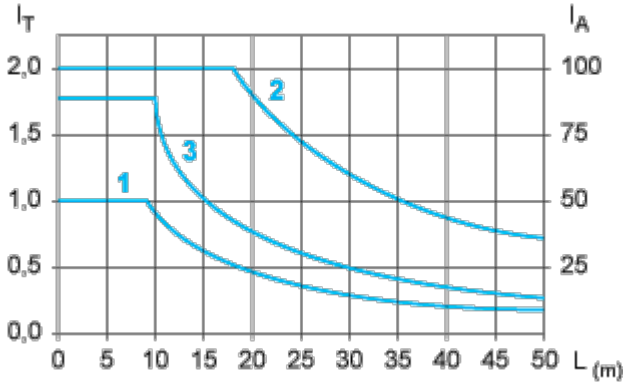

L Cable length

I_T Total current per sub base (A)

I_A Average current per channel (mA)

- (1) TSXCDP••2 and ABFH20H••0 cables with c.s.a. 0.08 mm² (AWG 28).
- (2) TSXCDP••3 cables with c.s.a. 0.34 mm² (AWG 22).
- (3) Cables with c.s.a. 0.13 mm² (AWG 26).

The curves are given for a voltage drop of 1 V in the cable. For n volts tolerance, multiply the length determined from the graph by n.

Image of product / Alternate images

Alternative

