

STD-Frame Solid State Molded Case Circuit Breaker

Information and Instruction Guide

Cost breakthrough for up to 3200A protection

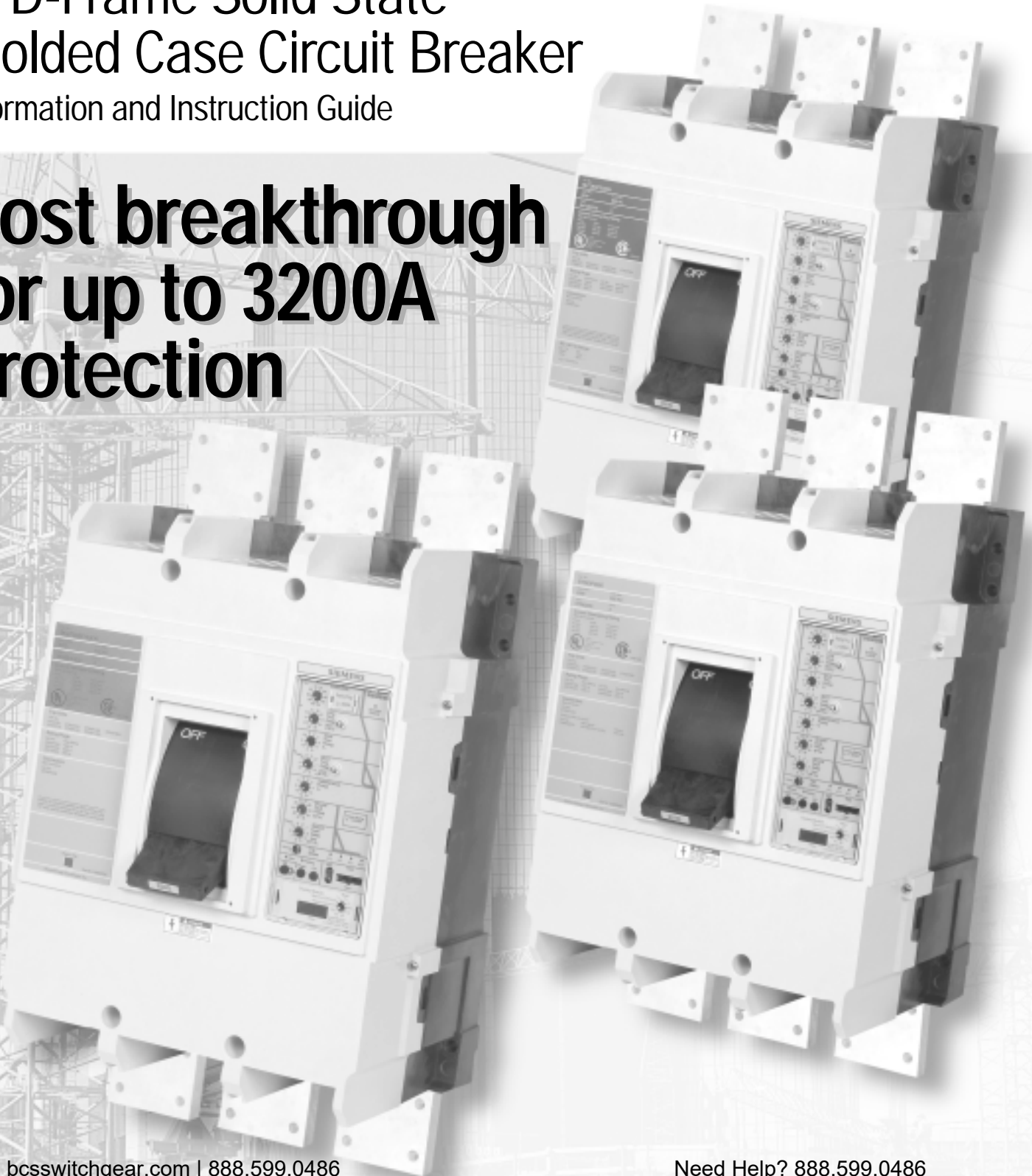



Table of Contents

General Information	3-4	Installation Instructions - Mounting of Auxiliary Switches	22-29
Introduction	3	Internal Accessories - Trip Alarm Switches	30
Interruption and Short Time Ratings	3	Installation Instructions - Mounting of Shunt Trip Assembly	31-39
UL Listed Interruption and Short-Time Ratings	3	Installation Instructions - Shunt Trip	40-42
IEC 947-2 Ratings	3	Installation Instructions - Mounting of Bell Alarm or Display Relay	43-46
Frame Sizes and Frame Ampere Ratings	3	Installation Instructions - Mounting of Remote Indicator Panel	47-52
Rating Plugs	3	Installation Instructions - Mounting of Pressure Wire Connector	53
Available Rating Plugs	3	Installation Instructions - Display Module or Ground Fault Monitor	54-56
Overcurrent Protection Configurations	3	Installation Instructions - Ground Fault Sensing and Relaying	57-61
RMS Current Sensing	3	Installation Instructions - Fixed Mounted Mechanical Interlock Assembly	62-63
Circuit Breaker Operation	4	Installation Instructions - Fixed Mounted Breaker Key Interlock	64
Maintenance	4	Installation Instructions - Mounting of Padlock Device Assembly	65-66
Description – Electronic Units for Siemens STD Frame Circuit Breaker	5-6	Installation Instructions - Mounting of Terminal Block Mount	67-68
Electronic Trip Unit	5	External Accessories - Control Terminal Blocks	69
Overcurrent Protection Configurations	5	Control Terminal Blocks	69
Operations – Fault Protection Adjustments	7	Mounting Bracket for Terminal Block	69
Trip Unit Current Shaping Adjustments	7	Installation Instructions - Mounting of Terminal Connector	70
Operations – Long-Time Fault Protection	8	Installation Instructions - Neutral Sensor	71-75
Adjustable Continuous Amps	8	External Accessories - MT and Expansion Plug for Siemens ACCESS Communications System	76
Adjustable Long Time Delay	8	Installing Electronic Trip Units in Zone Selective Interlocking or ACCESS Communications Systems	77-83
Operations – Short-Time Fault Protection	9	External Accessories - Universal Test Kit	84
Adjustable Short-Time Pickup	9	General Information	84
Adjustable Short-Time Delay	9	Operations	84
Operations – Instantaneous Fault Protection	10	External Accessories - Auxiliary Power Supply	85
Adjustable Instantaneous Pickup	10	Test Procedures	85
Instantaneous Override	10	Outline Dimension Drawing - STD 3200A	86
Discriminator Circuit (Making Current Release)	10	Ordering Information - Frames and Trip Units	87
Operations – Ground Fault Protection	11		
Adjustable Ground Fault Pickup	11		
Adjustable Ground Fault Delay	11		
Ground Fault Memory Circuit	11		
Ground Fault Sensing Schemes	11		
Operations – Ground Fault Sensing Schemes	12		
Residual (3-Phase, 3-Wire)	12		
Residual (3-Phase, 4-Wire)	12		
Source Ground	12		
Operating Instructions – Monitoring the Electronic Trip Unit	13		
Trip Unit Test and Monitoring Functions	13		
System Check Indicator	13		
Trip Status	13		
Integral Test Modes	13		
Installation Instructions – Electronic Trip Unit	14-16		
Installation of Electronic Trip Unit	14		
Installation Instructions – Rating Plug	17-18		
Installation Test Procedure	19-21		

NOTE: Information related to specific frame types and catalog numbers does not guarantee product availability. Technical information may change due to product revisions. Consult Siemens sales office concerning any variation of information contained herein.

	 DANGER
	<p>Hazardous voltage. Will cause death or serious injury.</p>
	<p>Turn off and lock out all power supplying the device prior to cover(s) removal or while cover(s) are removed and when installing any internal or external accessory.</p> <p>Replace the cover(s) and shield(s) before power supplying this device is turned on.</p>

Circuit breaker indicators shown in this booklet are for illustration purposes only. Circuit breakers are to be installed in "Tripped" or "Open" positions only.

IMPORTANT

The information contained herein is general in nature and not intended for specific application purposes. It does not relieve the user of responsibility to use sound practices in application, installation, operation, and maintenance of the equipment purchased. Siemens reserves the right to make changes in the specifications shown herein or to make improvements at any time without notice or obligations. Should a conflict arise between the general information contained in this publication and the contents of drawings or supplementary material or both, the latter shall take precedence.

NOTE

Authorized and qualified personnel—

For the purpose of this manual, a qualified person is one who is familiar with the installation, construction, or operation of the equipment and the hazards involved and:

- (a) **is trained and authorized** to de-energize, clear, ground, and tag circuits and equipment in accordance with established safety practices.
- (b) **is trained** in the correct care and use of protective equipment such as rubber gloves, hard hat, safety glasses or face shields, flash clothing, etc., in accordance with established safety practices.
- (c) **is trained** in rendering first aid.

SUMMARY

These instructions do not purport to cover all details or variations in equipment, nor to provide for every possible contingency to be met in connection with installation, operation, or maintenance. Should further information be desired or should particular problems arise that are not covered sufficiently for the purchaser's purposes, the matter should be referred to the local Siemens sales office listed on back of this instruction guide.

The contents of this instruction manual should not become part of or modify any prior or existing agreement, commitment, or relationship. The sales contract contains the entire obligation of Siemens Energy & Automation, Inc. The warranty contained in the contract between the parties is the sole warranty of Siemens Energy & Automation, Inc. Any statements contained herein do not create new warranties or modify the existing warranty.

General Information

Introduction

Siemens STD Frame Circuit Breakers offer current ratings up to 3200 Amps in a microprocessor-controlled Molded Case Circuit Breaker (MCCB).

With maximum ratings of 2000A, 2500A, and 3200A, STD Frame Breakers are suitable for many industrial and commercial applications. The available 150 KA (480V) interrupting rating leads the industry for a MCCB in this range.

Interruption and Short-Time Ratings

This breaker is available in three interrupting ratings. The interruption ratings and short-time ratings are listed in the following table.

UL-Listed Interruption and Short-Time Ratings

Interrupting Rate	Type	240V AC	480V AC	600V AC
Standard	STD	85	65	50
High	SHTD	150	100	85
Extra High	SHHTD	200	150	100
Short-Time Rating (T = 0.5 sec) = 50KA				

NOTE: Information contained here refers to product instructions and procedures and is not intended to indicate availability.

IEC 947-2 Ratings

These ratings apply to high (SHTD) interrupting rating only.

Interrupting Ratings Symmetrical RMS Amperes 50/60 Hz.	AC Voltage	3200A Frame	
	415	Icu	100
Ics		100	100
Icw		50	50
690	Icu	65	65
	Ics	65	65
	Icw	50	50

Frame Sizes and Frame Ampere Ratings

The STD Frame Breaker is available in three frame ratings: 2000A, 2500A, and 3200A. These frames are also offered in a version rated for 100% continuous operation. Refer to page 87.

Rating Plugs

The STD Frame Breaker is designed to use interchangeable rating plugs. With a rating plug, you can customize the effective ampere rating of the breaker to meet specific applications. The available rating plugs are listed in the following table.

Available Rating Plugs

Max Rating	Rating Plug Ampere Values (I _n)
2000	1000, 1200, 1600, 2000
2500	1600, 2000, 2500
3200	1600, 2000, 2500, 3000, 3200

Overcurrent Protection Configurations

Siemens Electronic Trip Units for the STD Frame breaker are available in seven overcurrent protection configurations to meet specific needs. The optional protection configurations are as follows:

Protection Configuration	Identifier
Long Time/Short Time	LS
Long Time/Instantaneous	LI
Long Time/Short Time/Instantaneous	LSI
Long Time/Short Time/Ground Fault	LSG
Long Time/Instantaneous/Ground Fault	LIG
Long/Short Time/Instantaneous/Ground Fault	LSIG
Fixed Long Time/Instantaneous	MLI

RMS Current Sensing

The Siemens microprocessor-controlled Electronic Trip Unit executes the overcurrent fault protection functions of the STD Frame Breaker.

The adjustment flexibility provided by the trip unit allows you to accommodate load changes and other protection requirements while still assuring optimum coordination and protection.

A standard feature of the trip unit is RMS current sensing. RMS sensing measures the true heating potential of the current waveform. RMS sensing allows for more accurate overcurrent protection and virtually eliminates nuisance tripping due to harmonic distortion of the current waveform.

General Information

Circuit Breaker Operation

With the mechanism latched and the contacts open, the operating handle is in the **OFF** position. Moving the handle to the **ON** position closes the contacts and establishes a circuit through the circuit breaker.

Under an overload or a short-circuit condition sufficient to trip the breaker automatically, the operating handle moves to a position between ON and OFF.

To relatch the circuit breaker after automatic operation, move the operating handle to the extreme OFF position. The circuit breaker is now ready for reclosing.

The overcenter toggle mechanism is trip free of the operating handle. This means an operator cannot use the handle to hold the circuit breaker closed when the unit is tripped.

After automatic operation, the handle moves to an intermediate position between ON and OFF, which indicates that it has been tripped.

Maintenance

Properly applied MCCBs normally do not require maintenance. However, you may wish to establish a routine inspection program. For detailed information, consult applicable NEMA publications or contact your local Siemens sales office.

Description

Electronic Trip Units For Siemens STD Frame Circuit Breakers

Electronic Trip Unit

This Electronic Trip Unit is a microprocessor controlled, multifunctional, overcurrent protective device for application with Siemens state-of-the-art STD Frame molded-case Circuit Breakers.

The adjustment flexibility provided by the trip unit allows you to easily accommodate load changes and other protective requirements while still assuring optimum coordination.

In addition to the adjustable protection functions, the trip unit is designed to use field-interchangeable rating plugs. These rating plugs allow the ampere rating of the breaker to be changed to meet specific applications.

For ease of installation and interchangeability in the field, the trip unit has been designed as a plug-in unit to mount directly unto an STD Frame breaker frame.

Current sensors within the STD Frame breakers provide signal currents and operating power for the trip unit. Therefore, the trip unit requires no external connections or control power to perform its protection functions.

Overcurrent Protection Configurations

The units are available in seven overcurrent protection configurations to meet specific protection requirements. Six trip units have Adjustable Continuous Current and Long Time Delay. Optional protection configurations are:

Protection Configuration	Identifier
Long Time/Short Time	LS
Long Time/Instantaneous	LI
Long Time/Short Time/Instantaneous	LSI
Long Time/Short Time/Ground Fault	LSG
Long Time/Instantaneous/Ground Fault	LIG
Long/Short Time/Instantaneous/Ground Fault	LSIG
Fixed Long Time/Instantaneous	MLI

As standard features, the trip unit has two built-in test functions and a fault identification function.

System Check is a built-in test function that continuously checks the status of the microprocessor and protective algorithms. A green LED on the front panel blinks approximately every three seconds when the microprocessor is correctly executing its protection routines.

Integral Test is a built-in test that allows the user to exercise the trip unit electronics. LED indicators display the testing status.

Trip Status is a fault identification function that stores information when the trip unit trips the circuit breaker. By pressing the Query button, you can display the cause of the breaker trip by illuminating one of four LED's. OL (overload), ST (short time), SC (short circuit), or GF (ground fault). Newer version trip units provide a Fault LED Reset Button for clearing the indicator.

Additional optional features include: Display Module for local current monitoring (field addable), Zone Selective Interlocking Communications for remote monitoring, and a Ground Fault Monitor for Ground Fault Warning applications.

Description

Electronic Trip Units For Siemens STD Frame Circuit Breakers

NOTE: Earlier model trip units may use (I_r) as the Rating Plug designator and (I_n) to denote (Max Rating). The designations for the current model trip unit are shown at right. Note however, that the change in designation has no effect on the switch settings used for selecting Continuous, Long Time, Short Time, Instantaneous, and Ground Fault pickup and delay values.

In addition, a Trip Status Reset Button is provided on newer version trip units for clearing the Trip Status LED's.

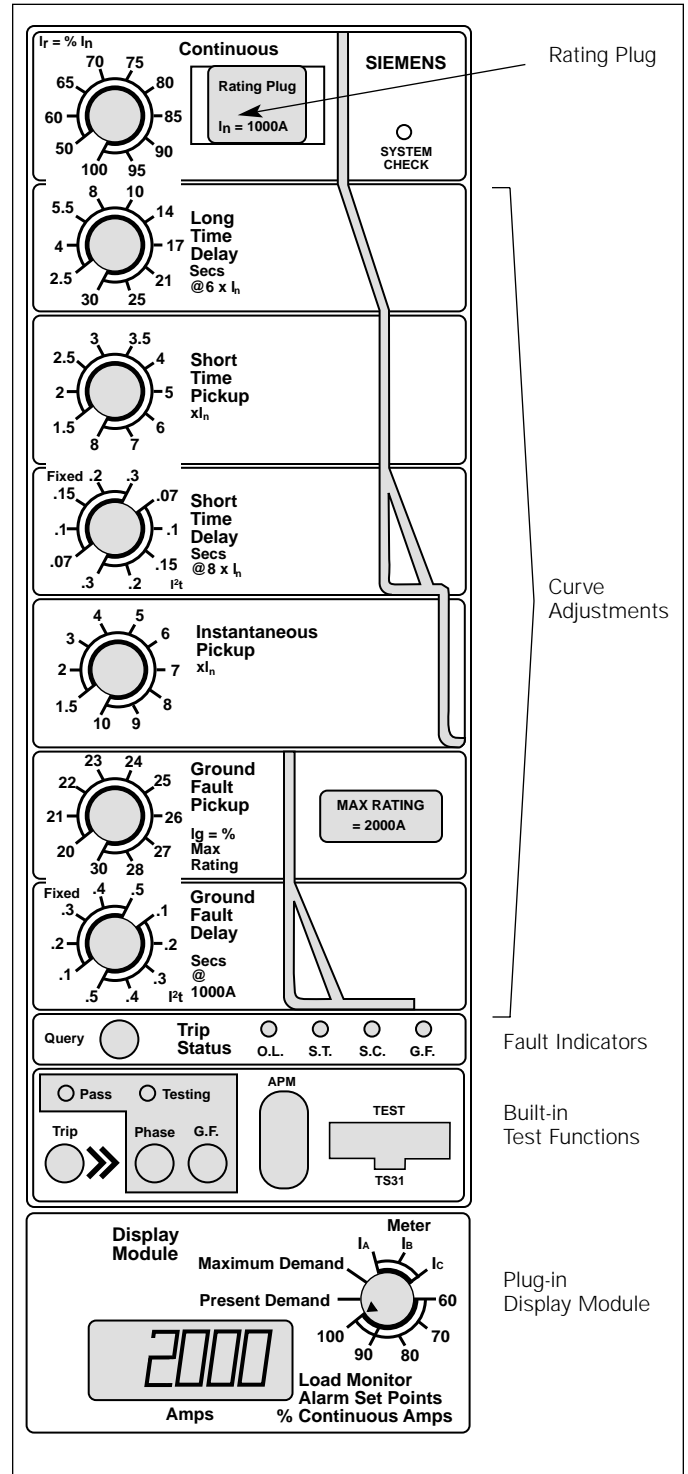

Typical Trip Adjustment Unit Panel

Operations

Fault Protection Adjustments

Trip Unit Current Shaping Adjustments

(This curve is for illustration purposes only.)

Amperes in Multiples of Rating Plug Value (I_n)

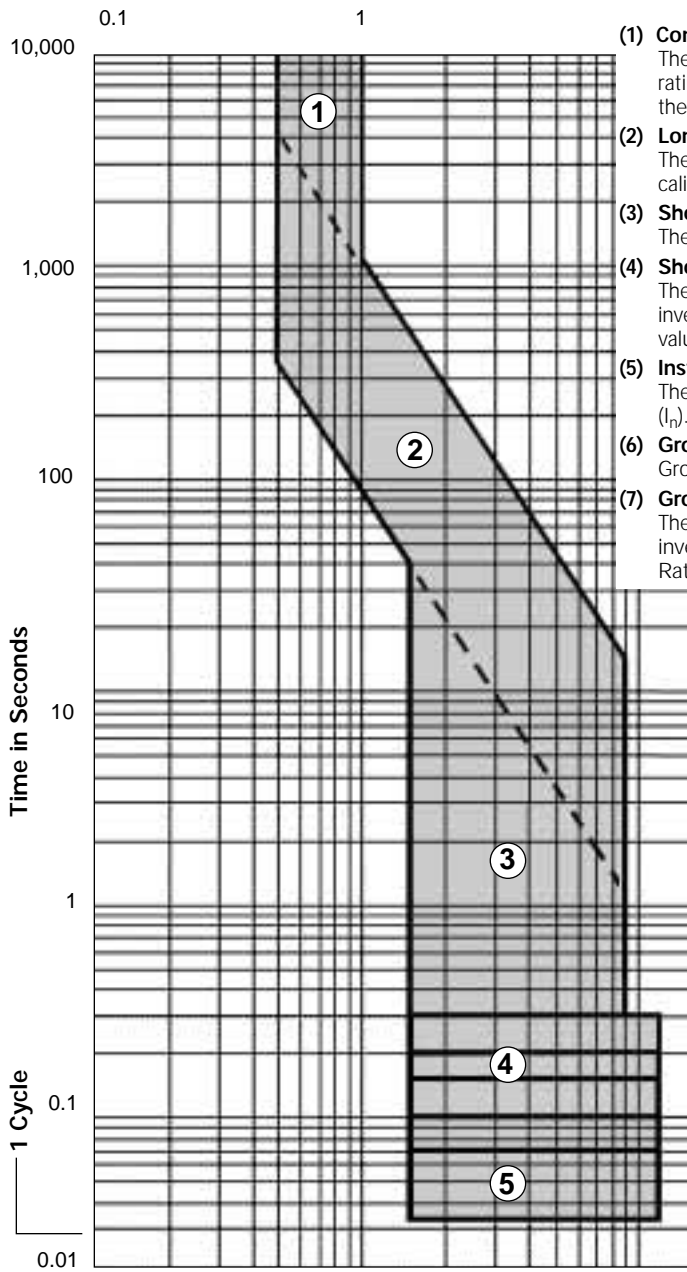

(1) Continuous Ampere Setting Region

The allowable continuous operating amperes is set to a percent of the rating-plug value. Note that the maximum continuous ampere is set by the rating-plug value (I_n).

(2) Long-Time Delay Region

The long-time delay is set to an inverse I^2t ramp function delay calibrated at 6 times the rating-plug value (I_n).

(3) Short-Time Pickup Region

The short-time pickup is set to a multiple of the rating-plug value (I_n).

(4) Short-Time Delay Region

The short-time delay is set to either a fixed delay (illustrated) or an inverse I^2t ramp function delay calibrated at 8 times the rating-plug value (I_n).

(5) Instantaneous Pickup Region

The instantaneous pickup is set to a multiple of the rating-plug value (I_n).

(6) Ground-Fault Pickup Region

Ground-fault pickup is set to a percent of the Max Rating.

(7) Ground-Fault Delay Region

The ground fault delay is set to either a fixed delay (illustrated) or an inverse I^2t ramp function delay calibrated at one-half of the Max Rating.

$I_g = \% \text{ Max Rating}$

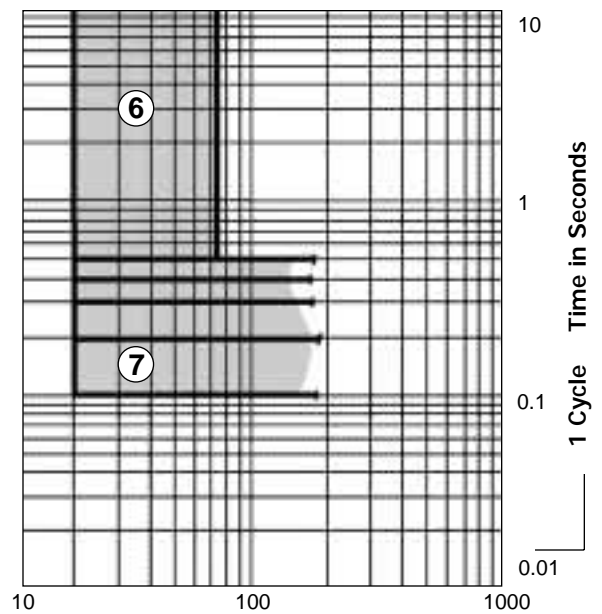

Operations

Long-Time Fault Protection

Adjustable Continuous Amps

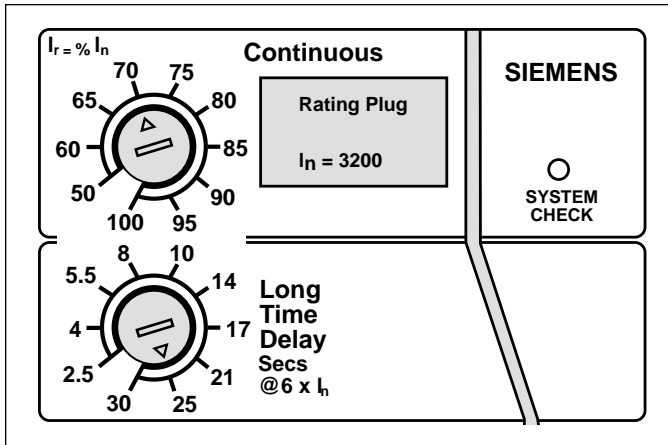

The Continuous Ampere Adjustment sets the current level at which the breaker will continuously operate without initiating a tripping sequence. The continuous operating current may be set to 50%, 60%, 65%, 70%, 75%, 80%, 85%, 90%, 95%, and 100% of the rating plug value (I_n).

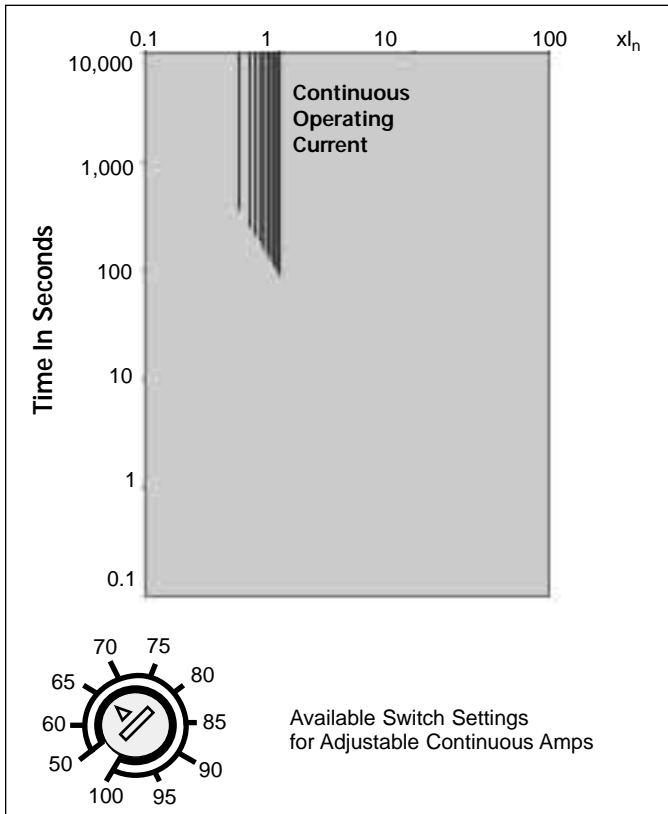

Continuous Operating Current

Adjustable Long-Time Delay

The long-time pickup is nominally set at 115% of the continuous amps setting.

The long-time delay adjustment is used to set the tripping delay of the STD Frame breaker based on the magnitude of the overcurrent.

On Siemens Electronic Trip Units, the long-time delay, which is an inverse I^2t ramp function, may be set to a calibrated value of 2.5, 4, 5.5, 8, 10, 14, 17, 21, 25, or 30 seconds at a current equal to 6 times the rating plug value (I_n).

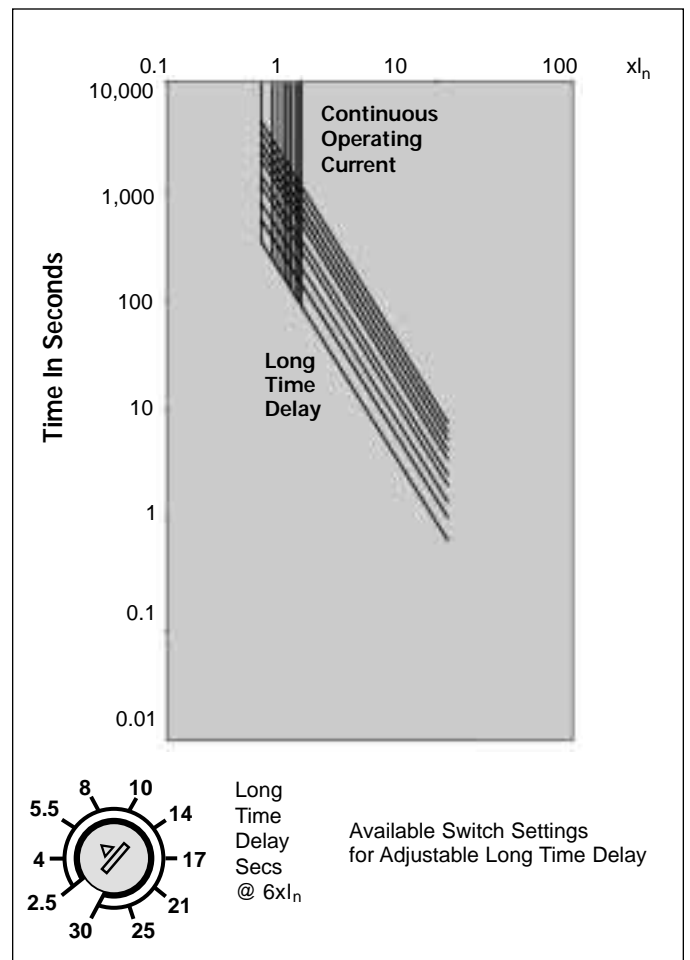

Long-Time Delay

Operations

Short-Time Fault Protection

Adjustable Short-Time Pickup

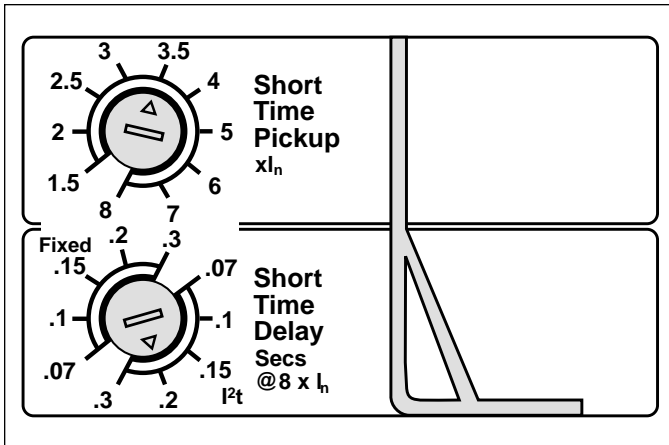

The short-time pickup adjustment is used to set the level of high current the breaker will carry for a short period of time without tripping. This adjustment, together with the short-time delay, allows downstream breakers time to clear short-circuit faults without tripping the upstream breakers. For Siemens Electronic Trip Units, the short-time pickup may be set to 1.5, 2, 2.5, 3, 3.5, 4, 5, 6, 7, or 8 times the rating plug value (I_n).

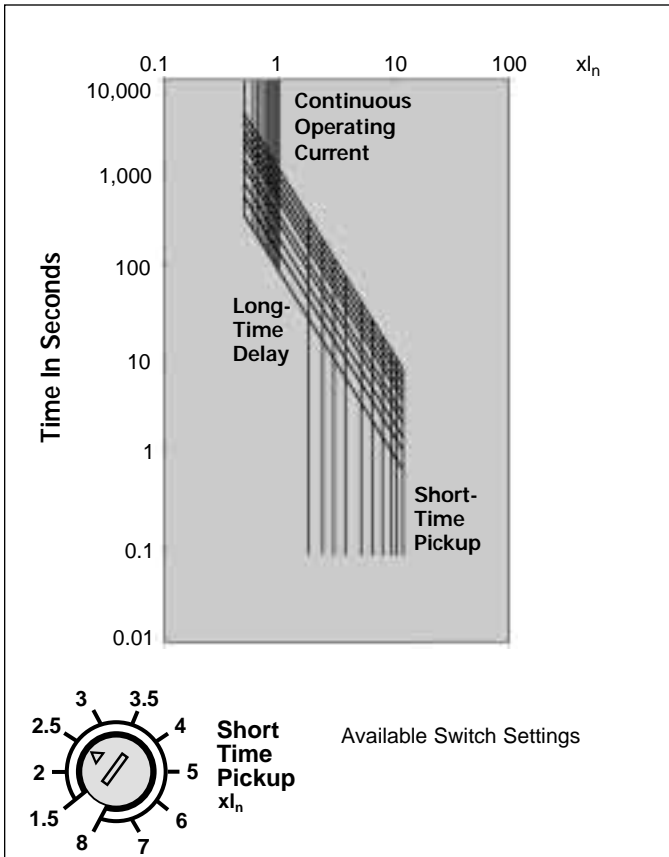

Short-Time Pickup

Adjustable Short-Time Delay

The short-time delay adjustment is used to set the time interval the breaker will wait before responding to the current value selected on the short-time pickup adjustment. There are two modes of operation of this adjustment on all Siemens Electronic Trip Units: one is a fixed delay, the other is an inverse I^2t ramp delay. The I^2t delay has the characteristic of being inversely proportional to the square of the magnitude of the overcurrent. This means that higher overcurrents have shorter delays and lower overcurrents have longer delays. This characteristic allows for better coordination with downstream circuit breakers and fuses. In the fixed delay mode, the short-time delay may be set to 0.07, 0.1, 0.15, 0.2, or 0.3 seconds. In the inverse I^2t ramp short-time delay mode, the delay may be set to a calibrated value of 0.07, 0.1, 0.15, 0.2, or 0.3 seconds at a current equal to 8 times I_n .

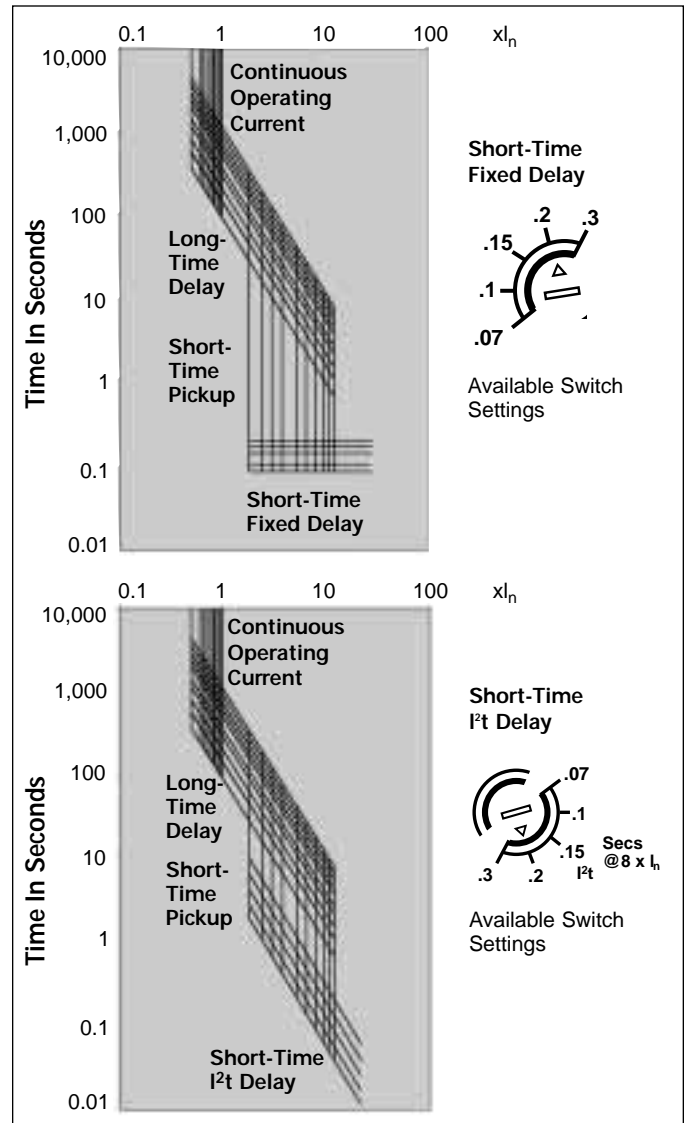

Short-Time Delay

Operations

Instantaneous Fault Protection

Adjustable Instantaneous Pickup

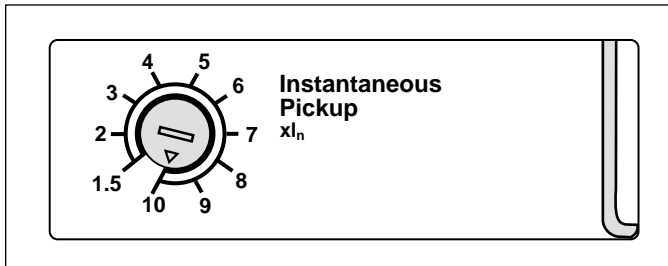

The instantaneous-pickup adjustment is used to set the current level at which the breaker will trip without an intentional time delay. Nondelayed tripping, as a result of a severe overcurrent condition, minimizes potential damage to electrical systems and equipment. The instantaneous-pickup adjustment may be set to 1.5, 2, 3, 4, 5, 6, 7, 8, 9, or 10 times the rating plug value (I_n).

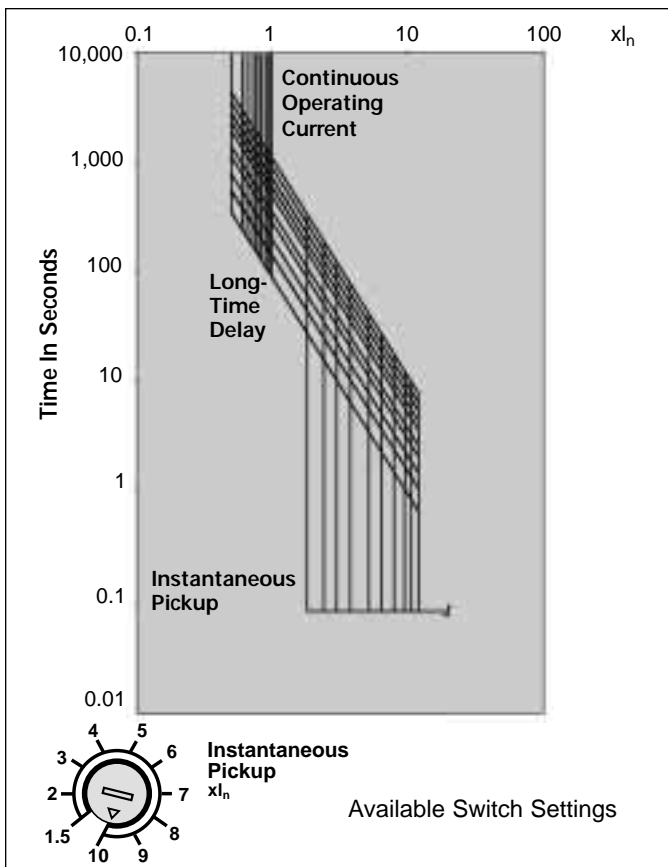

Instantaneous Pickup

Instantaneous Override

On all trip units, an instantaneous override function has been provided. It is set at the approximate short-time rating of the respective breaker frame size. This allows the breaker to ride through high faults up to its short-time capability; however, it is self-protecting above these values.

STD Breaker Frame Size	Short Time kA Rating (0.500 seconds max.)
3200A	50

Discriminator Circuit (Making Current Release)

This circuit overrides the short-time delay function should the breaker attempt to close into a faulted system, tripping the breaker instantaneously. The discriminator function is enabled for the first six cycles of current flow, after which normal short-time characteristics operate.

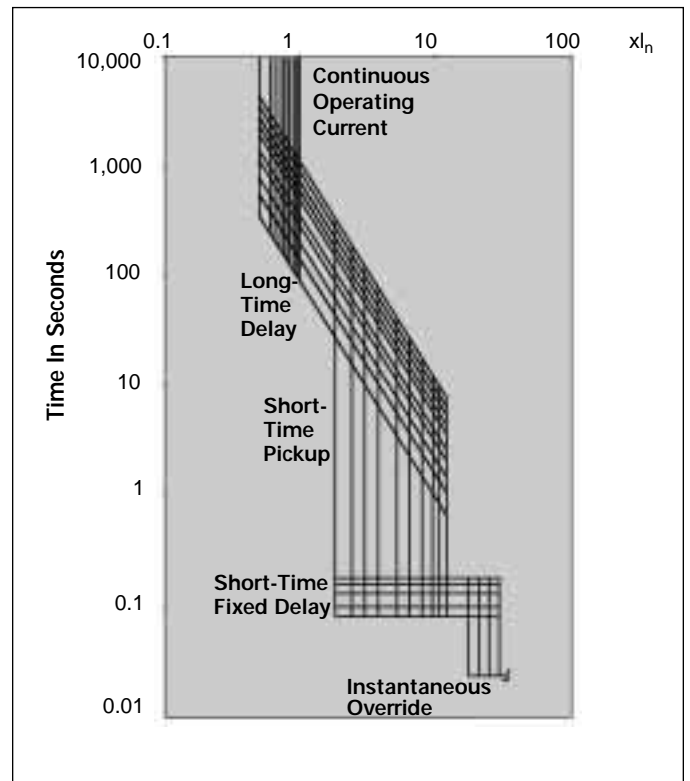

Instantaneous Override (Illustrated with Short-Time Fixed Delay)

Operations

Ground Fault Protection

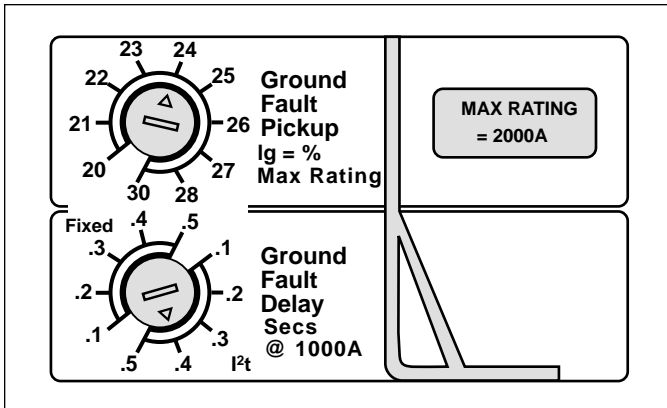

Adjustable Ground Fault Pickup

The ground-fault pickup adjustment is used to set the level of ground current at which circuit interruption will be initiated. Together with the ground-fault delay, this adjustment allows selective tripping between main and feeder or other downstream breakers. The available ground fault pick-up settings as a percent of the STD Max Rating are listed below. In compliance with the National Electric Code (NEC 230-95), no trip point setting exceeds 1200A.

Max Rating	Setting = % Max Rating									
3200A	20	21	23	25	27	29	31	33	35	37
2500A	20	23	26	29	32	35	38	41	44	48
2000A	20	21	26	29	32	35	38	41	44	48

Adjustable Ground Fault Delay

The ground-fault delay adjustment is used to set the time interval the breaker will wait before responding once the ground-fault pickup level has been reached. There are two modes of operation for this adjustment for Siemens Electronic Trip Units; one is a fixed delay and the other is an inverse I^2t ramp delay. In the fixed delay mode, the ground-fault delay may be set to 0.1, 0.2, 0.3, 0.4, or 0.5 seconds. In the inverse I^2t delay mode, the delay may be set to a calibrated value of 0.1, 0.2, 0.3, 0.4, or 0.5 seconds at a current equal to 0.5 times the Max Rating. The inverse I^2t ramp delay reverts to a fixed delay of the same value when the ground current (I_g) exceeds 50% of the Max Rating.

Ground Fault Memory Circuit

Electronic Trip Units with ground fault protection come equipped with a ground fault memory circuit. This circuit integrates ground fault currents with time. This provides added protection by preventing ground fault delay circuits from being reset to zero when the ground fault currents are intermittent and erratic. Time constants for the

current integration are preset within the trip unit as a function of the Ground Fault Delay.

Ground Fault Sensing Schemes

The trip unit can be configured to accommodate the following ground fault sensing schemes.

- 3-Phase, 3-Wire Residual
- 3-Phase, 4-Wire Residual
- Source Ground

All that is required of the user to configure the trip unit to support these protection schemes is to set the ground fault selection switch to the desired configuration. The selection switch is on the left side of the trip unit and must be set prior to the trip unit being installed in the STB breaker.

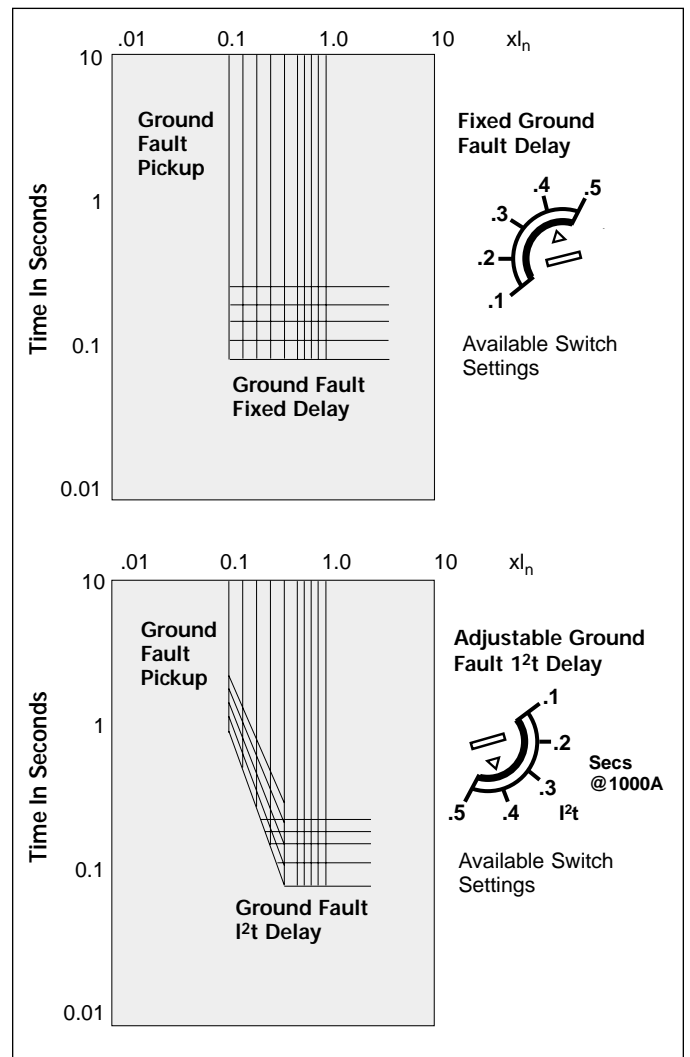

Ground Fault Delay

Operations

Ground Fault Sensing Schemes

The following are brief descriptions of the ground fault sensing schemes as they relate to the Siemens Electronic Trip Unit. Detailed technical and application information of the ground fault sensing schemes is contained in NEMA Standard No. PB 2.2 "Application Guide for Ground Fault Protective Devices for Equipment."

Residual (3-Phase, 3-Wire): Under normal system conditions (without ground fault), the vector sum of the phase currents being monitored by the trip unit is zero. This is also true under the condition of an overcurrent phase-to-phase fault and phase-unbalance condition. When a phase-to-ground fault occurs, the vector sum of the phase currents is equal to the fault current. The trip unit's microprocessor computes the vector sum in the execution of the ground fault protection function. The trip unit utilizes the internal breaker current transformers. No external current transformers are required.

Residual (3-Phase, 4-Wire): In the 3-phase, 4-wire residual scheme, a fourth current transformer is connected in the neutral conductor to "sense" normal neutral currents. Under normal system conditions, the vector sum of the currents in all phases equals (minus) the neutral current. This is also true under the condition of an overcurrent phase-to-phase fault and phase-unbalance condition. When a phase-to-ground fault occurs, the fault current returns via a path other than the neutral. Therefore, the vector sum of the phase currents plus the neutral current equals the fault current. This current is computed by the trip unit and used in the execution of the ground fault protection function.

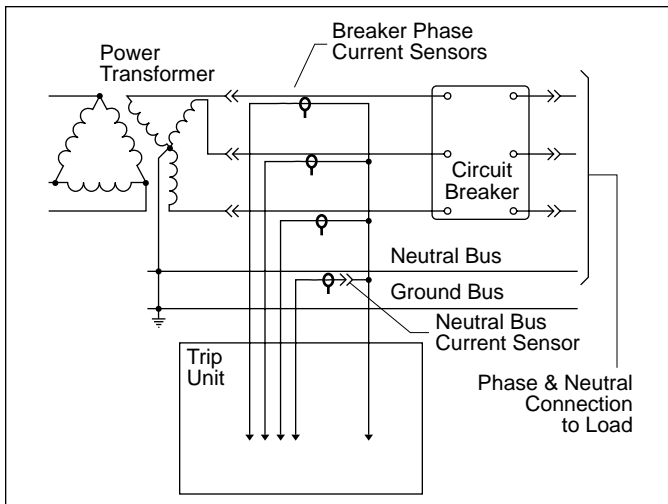

Residual Sensing: Circuit Breaker Wiring for Ground Protection (3-Phase, 4-Wire System Shown)

Source Ground: In this scheme, the phase and neutral currents are not used in detecting and processing ground faults. The trip unit executes the ground fault protection function based on data from a ground current sensor. This sensor is located on the neutral connection to ground at the service entrance, and is connected to the neutral transformer input terminals on the trip unit. The switch on the trip unit is set to "ground return." (Refer to page 14 for the switch location.)

NOTE: For neutral and source ground sensor installation, see page 71.

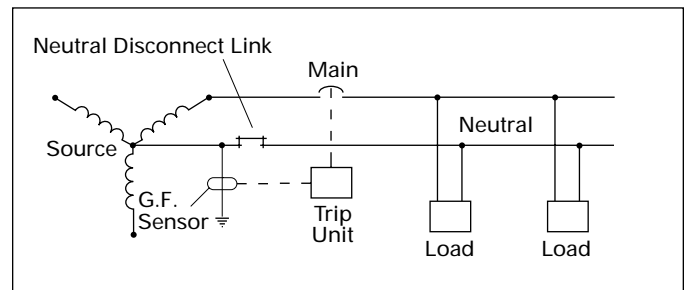

Source Ground Current

Operations

Monitoring the Electronic Trip Unit

Trip Unit Test and Monitoring Functions

Siemens Electronic Trip Unit is equipped with three standard test and monitoring functions to aid in the installation and operation of the STD Frame breaker.

System Check Indicator

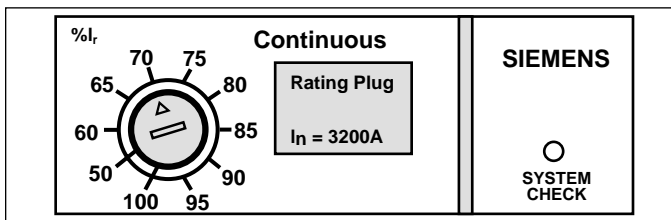

The System Check Indicator is a green LED that blinks approximately once every three seconds when the microprocessor is correctly executing its protection routines.

The trip unit derives its operating power from the phase currents in the STD Frame breaker. The phase current required to operate the trip unit is approximately 20% of the Max Rating. If the microprocessor is not functioning or the phase current is below the 20% value, the LED will not light.

Trip Status

NOTE: Newer version Trip Units feature a Trip Status Reset Button for clearing the Trip Status LED's.

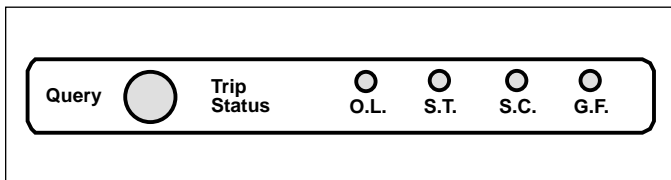

The trip Query button and Trip Status indicator lights allow the user to determine what type of fault caused the trip unit to trip the breaker. Fault indicators are provided for:

- O.L. – Overload or Long Time Fault
- S.T. – Short Time Fault
- S.C. – Short Circuit or Instantaneous Fault
- G.F. – Ground Fault

When a fault occurs, the fault information is stored in the trip unit. When the Query button is depressed, the latched fault indicator will light. The energy to power the indicators is automatically stored in the trip unit, eliminating the need for a battery. A hole is provided in the transparent cover to allow access to the Query button.

NOTE: During trip unit power up, a fault indicator LED will latch, providing a means to check that the circuitry is correctly operating. In case of a fault, the correct indicator will be latched to the fault position. The indicator circuitry will latch the most recent event.

Integral Test Modes

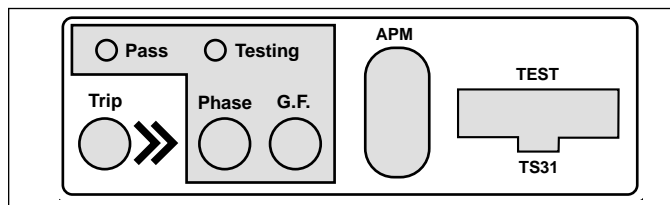

The integral test function enables the user to “exercise” the trip unit electronics, the magnetic latch, and the breaker mechanism. The purpose of the integral test function is to provide the user an easy means to conduct a “go/no go” test before bringing the breaker on-line. After the breaker has been brought on-line, it may be used during routine inspection and maintenance.

Both phase fault current protection and ground fault current protection may be tested. The integral ground fault test function tests the circuit breaker’s ground fault protection system.

Electrical power to operate the integral test function is provided internally if the breaker is closed and the phase currents are greater than 20% of the Max Rating, or by a plug-in power source (see Accessories section).

The user may execute the test function in either a “no trip” mode, which will test only the trip unit electronics, or a “trip” mode, which will also test the magnetic latch and breaker mechanism. The execution of the integral test function in both the “no trip” and “trip” modes is based on the settings of the long time delay and ground fault delay adjustments. Therefore, the Phase Test will take several seconds to execute and the Ground Fault Test will appear to be nearly instantaneous.

To execute a test in the “no trip” mode, depress the appropriate pushbutton (Phase or GF). As the trip unit is performing the test, the Testing Indicator will light. If the trip unit successfully passes the test, the Pass Indicator will light. If the Pass Indicator does not light after the Testing Indicator indicates that the test is complete, a more extensive test should be run with Siemens TS-31 Universal Test Kit (see Accessories).

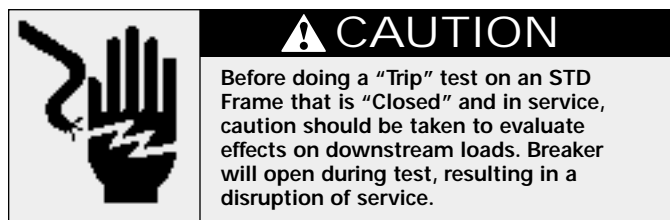

To exercise the magnetic latch and breaker mechanism, select a “trip mode” test. To do this, press the appropriate test button (Phase or GF) while pressing the trip button.

Installation Instructions

Electronic Trip Unit



⚠ DANGER
Hazardous voltage.
Will cause death or serious injury.
Turn off and lock out all power supplying the device prior to cover(s) removal or while cover(s) are removed and when installing any internal or external accessory.
Replace the cover(s) and shield(s) before power supplying this device is turned on.



⚠ WARNING
Do not attempt to install a trip unit with the breaker "Closed." Make certain breaker is "Tripped." Personal injury or mechanical damage may occur.



2. Lift off front cover.

Installation of Electronic Trip Unit

The STD Frame breaker has a built-in interlock device that prevents the breaker from being closed when there is no trip unit installed. This same interlock device will trip the breaker when the trip unit is removed.

To install the trip unit, the front cover of the breaker must first be removed.

On trip units with ground fault protection, the ground fault selection switch on the side of the trip unit must be set to the appropriate sensing scheme—Residual or Source Ground— before installing the trip unit. The trip unit is preset at the factory to a residual sensing scheme.

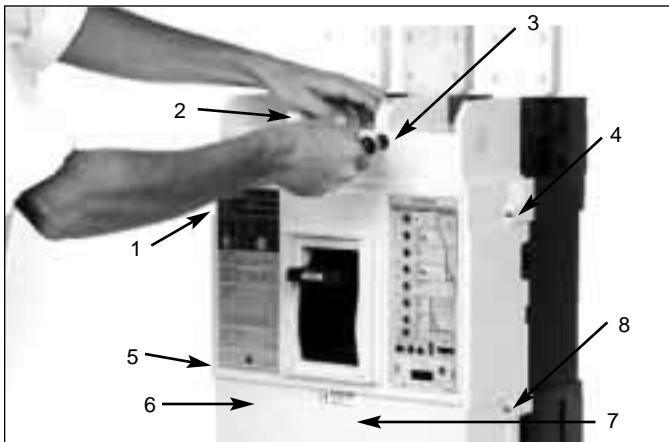

1. Remove 8 screws from breaker front cover.

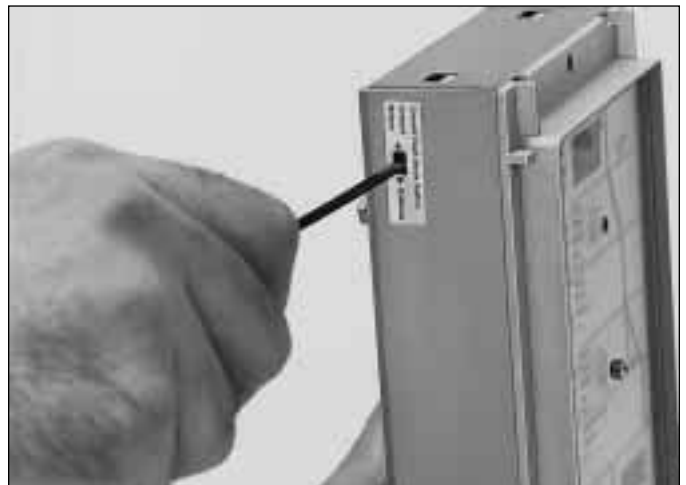

3. Set ground fault selection switch.

Installation Instructions

Electronic Trip Unit

Before attempting to install the trip unit, check the label on the side of the unit to make sure that it is the correct unit for the STD Frame breaker. A mechanical rejection scheme will prevent the installation of a trip unit into a breaker for which it is not intended.



4. Check label on side of trip unit.

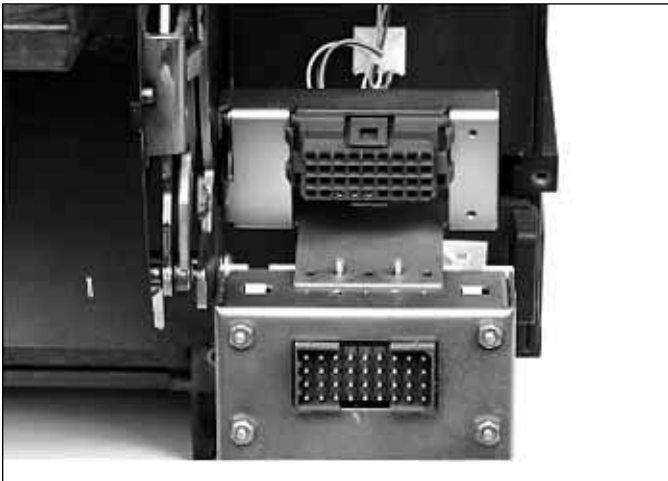

5. Check alignment of pins and holes.



6. Mate pin connectors.

Mate the connector half on the back of the trip unit with its corresponding connector half in the breaker.

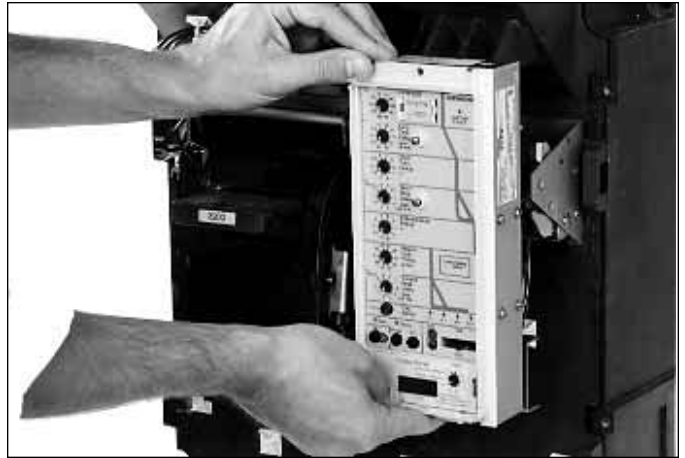

7. Lower trip unit onto support plate.

After the connector has been mated, lower (push) the trip unit onto the support plate. The pins on the support plate will fit into the holes in the bottom of the trip unit.

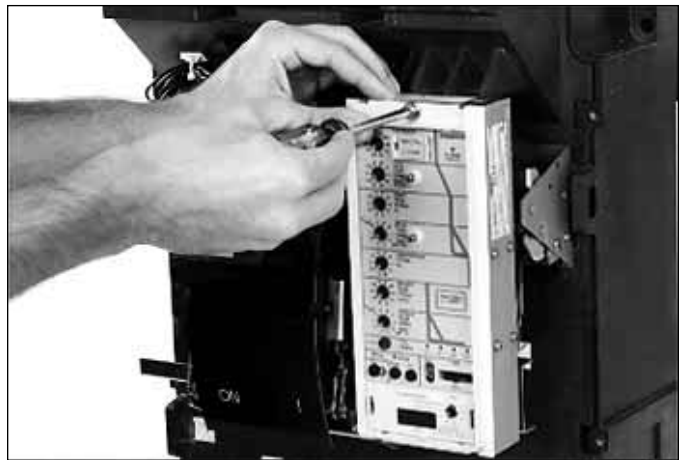

8. Secure trip unit.

Secure the trip unit in place with the retaining screw located at the top of the trip unit. Torque 6 to 8 in-lbs (.7 –.9 Nt-mtr). If trip unit top is not secured correctly, the interlock will prohibit closing of the breaker.

NOTE: Before energizing the breaker, be sure to install a correct rating plug. See page 17

Installation Instructions

Electronic Trip Unit



9. Replace circuit breaker front cover.



10. Re-install the eight screws that hold the front cover in place.
- a. Tighten screws 2, 3, 6, and 7 to 68-75 in lb (7.7 – 8.5 Nt-mtr).
 - b. Tighten screws 1, 4, 5, and 8 to 28-32 in lb (3.2 – 3.6 Nt-mtr).

Installation Instructions

Rating Plug



⚠ DANGER
Hazardous voltage.
Will cause death or serious injury.
Turn off and lock out all power supplying the device prior to cover(s) removal or while cover(s) are removed and when installing any internal or external accessory.
Replace the cover(s) and shield(s) before power supplying this device is turned on.



⚠ WARNING
Do not attempt to install or remove a rating plug with the breaker "Closed" or "Charged." Personal injury or mechanical damage may occur. Make certain breaker is "Open" or "Discharged."

Breaker should always be in the "Open" position when there is no rating plug in the trip unit.



1. Remove trip unit screws that hold the transparent cover.

The rating plug and adjustments on the front panel of the trip unit are protected by a transparent cover. Prior to installing a rating plug or setting the adjustments on the trip unit, this cover must be removed. Unscrew the two screws that hold it in place, and carefully pry the cover loose with a small screwdriver.

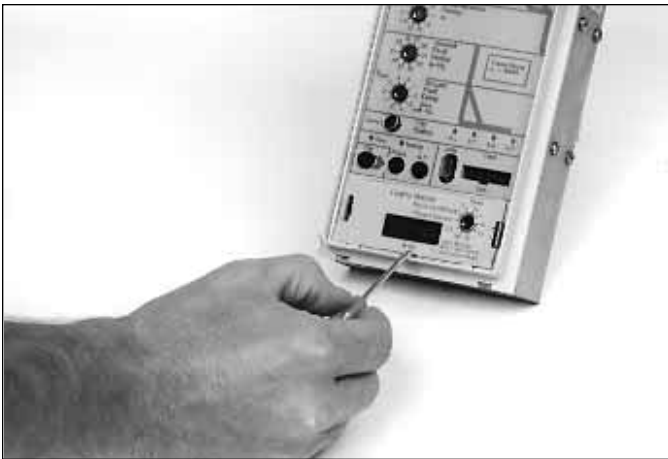

2. With a small screwdriver, gently pry the cover loose at one end and remove it carefully.



3. Check label on the rating plug.

Check the rating plug label to verify that it is a correct plug for the trip unit. If it is not a correct plug, the pins will not mate with the plug receptacle.

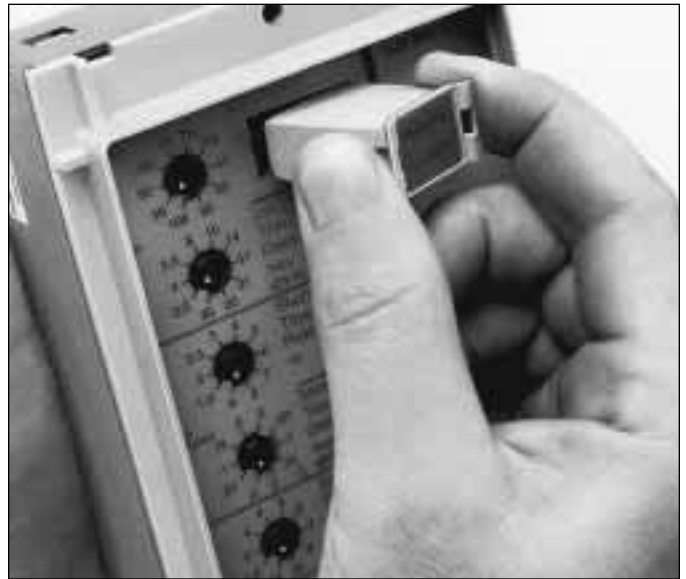

4. To insert rating plug, align plug receptacle and press into place.

To insert a rating plug in the trip unit, align the plug with the plug receptacle and press the plug into place. The clips on the plug hold it in place.

To remove a rating plug, squeeze the clips and pull the plug from the plug receptacle. Since the plug is held in place by compression, some force will be required to remove the plug.

Installation Instructions

Rating Plug



5. To replace the cover, bow slightly in the middle and snap into place.

After the rating plug has been inserted and the necessary setting adjustments have been made, replace the cover by sliding the protective shield into the top lip of the trip unit, bowing slightly in middle, and pressing down with thumb on bottom to snap shield into place. Replace the two special retaining screws.



6. The cover may be sealed for tamper evident protection.

After the cover has been replaced, a wire may be inserted through the holes in the screws and secured with a tamper-evident seal.

Installation Test Procedure



⚠ DANGER

Hazardous voltage. Will cause death or serious injury.

Turn off and lock out all power supplying the device prior to cover(s) removal or while cover(s) are removed and when installing any internal or external accessory.

Replace the cover(s) and shield(s) before power supplying this device is turned on.



SAFETY INSTRUCTIONS

GENERAL

The Siemens Type STD circuit breaker may be equipped with integral ground fault protection. These devices are identified by a "G" in the trip unit catalog number and the presence of the ground fault adjustments. The National Electrical Code® requires that these devices be performance tested when first installed [215-10, 230-95 (c), 240-13]. These instructions are intended to guide the installer in meeting this requirement.

GENERAL INSTRUCTIONS

1. The interconnected system shall be evaluated by qualified personnel when initially installed. It is also suggested this be done periodically thereafter.
2. The proper location of the sensors around the bus of the circuit to be protected shall be determined. This can be done visually, with knowledge of which bus is involved.
3. The grounding points of the system shall be verified to determine that ground paths do not exist that would bypass the sensors.
4. The polarity of the sensor connections must agree with the installation instructions to avoid improper operation.

5. A simulated test is to be done using a low-voltage, high-current source. This test is not intended to verify the calibration of the ground fault protection but to verify it is properly functioning.
6. The results of this testing should be recorded on the form provided at the end of this document or on other appropriate forms and should be available to the inspection authority.
7. These breakers may be set for different modes of operation, Residual or Ground Return, as described in the instructions supplied with the circuit breaker. For further information on applications, refer to the NEMA standards publication No. PB 2.2 Application Guide For Ground Fault Protective Devices for Equipment.¹

OPERATION TEST

SWITCH SETTING - RESIDUAL Outgoing Circuit Method 3 Phase / 3 Wire

Using Figure 1, individually test breaker poles A, B, and C for proper Ground Fault operation.

Each of the circuit breaker's front panel controls should be set to the highest setting. Using a low-voltage current source, apply a test current equal to 125 percent of the ground fault pickup setting to one pole of the circuit breaker. The circuit breaker must trip.

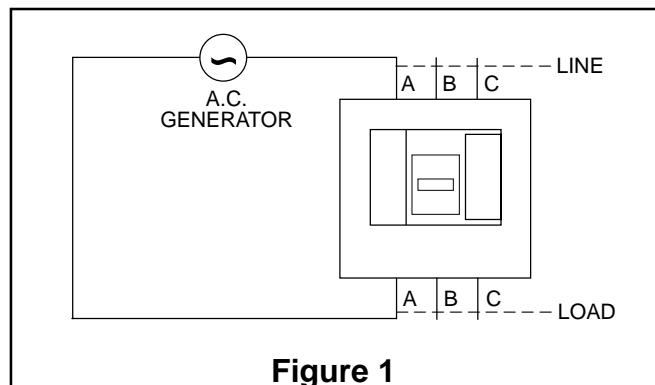
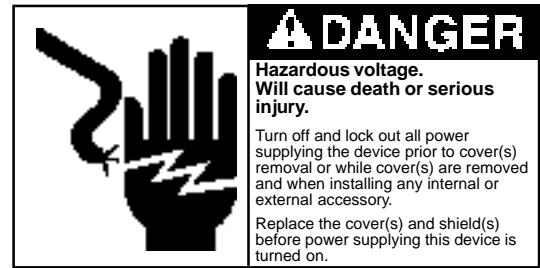

Figure 1



Installation Test Procedure

WARNING:

NEVER pass test current through an unterminated Neutral Sensor. Permanent sensor damage may occur if operated in this manner.

Using a suitable means, short the X1/ wire and X2/ wire connections together on the Neutral Sensor. Re-apply the 125 percent test current to the breaker pole under test. The breaker must trip. Reduce the test current to ZERO and remove the shorting means from the Neutral Sensor.

3 Phase / 4 Wire

Using Figure 2, individually test breaker poles A, B, and C in conjunction with the proper Neutral Sensor for proper Ground Fault operation.

**GF SWITCH SETTING - GROUND RETURN
 Ground Return Method
 3 Phase / 3 Wire or 3 Phase / 4 Wire**

Each of the circuit breaker's front panel controls should be set to the highest setting. Using a low-voltage current source, apply 125 percent of the ground fault pickup setting to one pole of the circuit breaker. The circuit breaker must not trip. Reduce the test current to zero.

Each of the circuit breaker's front panel controls should be set to the highest setting. Using a low-voltage current source, apply a current equal to 125 percent of the ground fault pickup setting per Figure 2. The circuit breaker must trip.

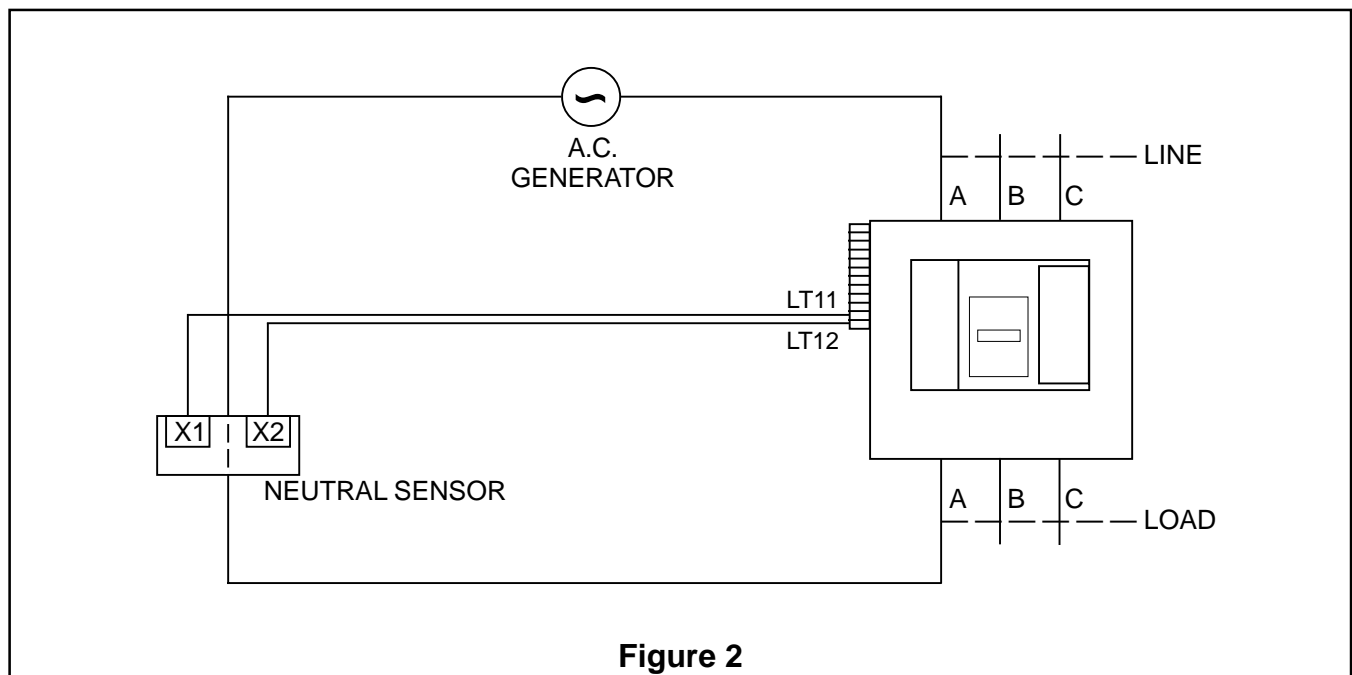
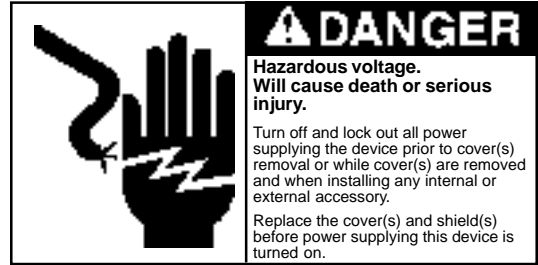

Figure 2



Installation Test Procedure

GROUND FAULT TEST RECORD	
Date Tested	Circuit Breaker No.
Tested By	
Results	

GROUND FAULT TEST RECORD	
Date Tested	Circuit Breaker No.
Tested By	
Results	

¹NEMA PB 2.2 is available from: National Electrical Manufacturers Association
 2101 L. Street, N.W., Suite 300
 Washington, D.C. 20037

Siemens Energy & Automation, Inc.
Bellefontaine, OH 43311 U.S.A.

Installation Instructions



⚠ DANGER

Hazardous voltage. Will cause death or serious injury.

Turn off and lock out all power supplying the device prior to cover(s) removal or while cover(s) are removed and when installing any internal or external accessory.

Replace the cover(s) and shield(s) before power supplying this device is turned on.



⚠ WARNING

Mechanical Hazard. Mechanism can cause severe injury when cover is removed.

Before removing cover trip device by pushing "Push - To - Trip" button.



SAFETY INSTRUCTIONS

NOTE: These instructions outline the recommended installation procedure.

Tools Required: 1/4" flat blade screwdriver, 1/4" screw starter (magnetic or clip), #2 phillips screwdriver, #3 phillips screwdriver.

MOUNTING OF AUXILIARY SWITCHES

- Accessory installation should be completed before the breaker is mounted and connected. **If the breaker is installed turn off and lock out all power supplying the circuit breaker prior to cover removal or while cover is removed.** For ease of installation, it is highly recommended that the breaker be disconnected and removed from the panel or the enclosure.

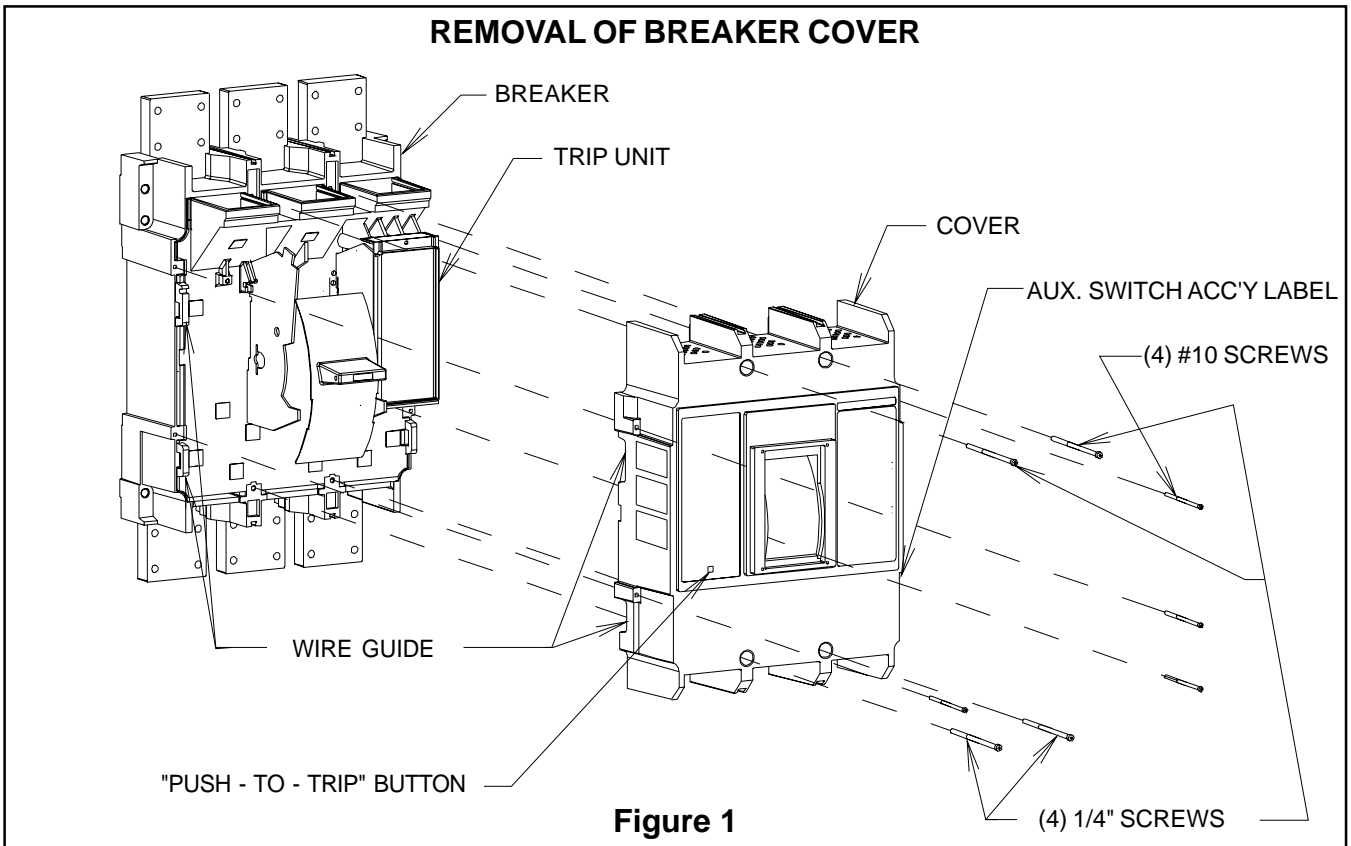

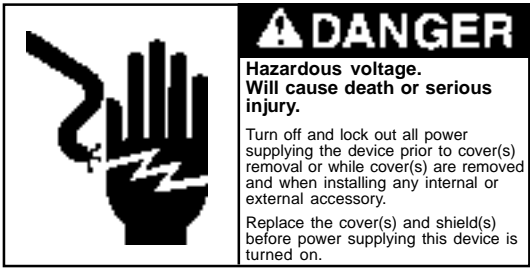

Installation Instructions

2. Trip breaker by pushing the "Push-to-Trip" button.
3. To install the auxiliary switches the breaker cover and trip unit must first be removed.
4. Remove the breaker cover by removing the (4) #10 Phillips head screws at the corners and the (4) 1/4" Phillips head screws in recesses of the cover (See Figure 1, Page 1).
5. Remove the trip unit retaining screw (See Figure 2).
6. Slide the trip unit up to clear the support bracket pins (See Figure 2).
7. Remove the trip unit by pulling it off the trip unit plug (See Figure 3).

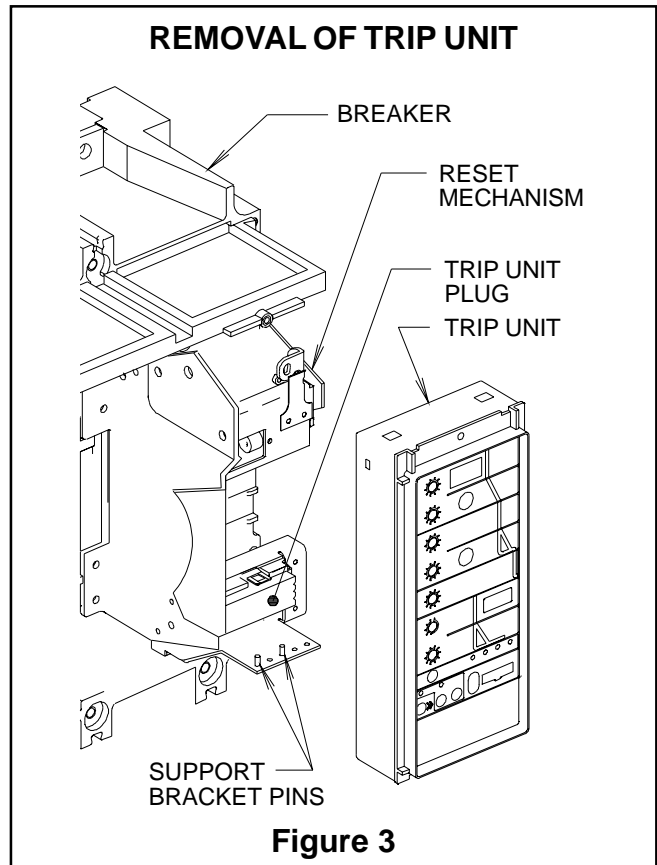
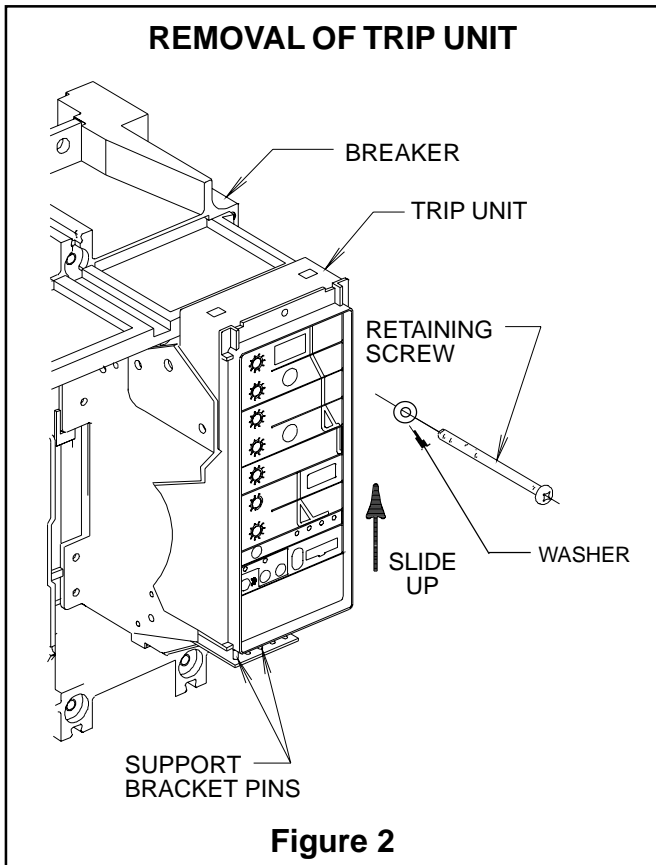

	⚠ DANGER
	Hazardous voltage. Will cause death or serious injury.
	Turn off and lock out all power supplying the device prior to cover(s) removal or while cover(s) are removed and when installing any internal or external accessory. Replace the cover(s) and shield(s) before power supplying this device is turned on.

Installation Instructions

- 8. Position the auxiliary switches assembly so that the bracket legs align with the reset mechanism slots (See Figures 4 and 5). Slide the bracket legs into the reset mechanism slots.
- 9. Shift the auxiliary switches assembly to the left until the bracket mounting hole aligns with the hole in the reset mechanism (See Figure 7, Page 4).

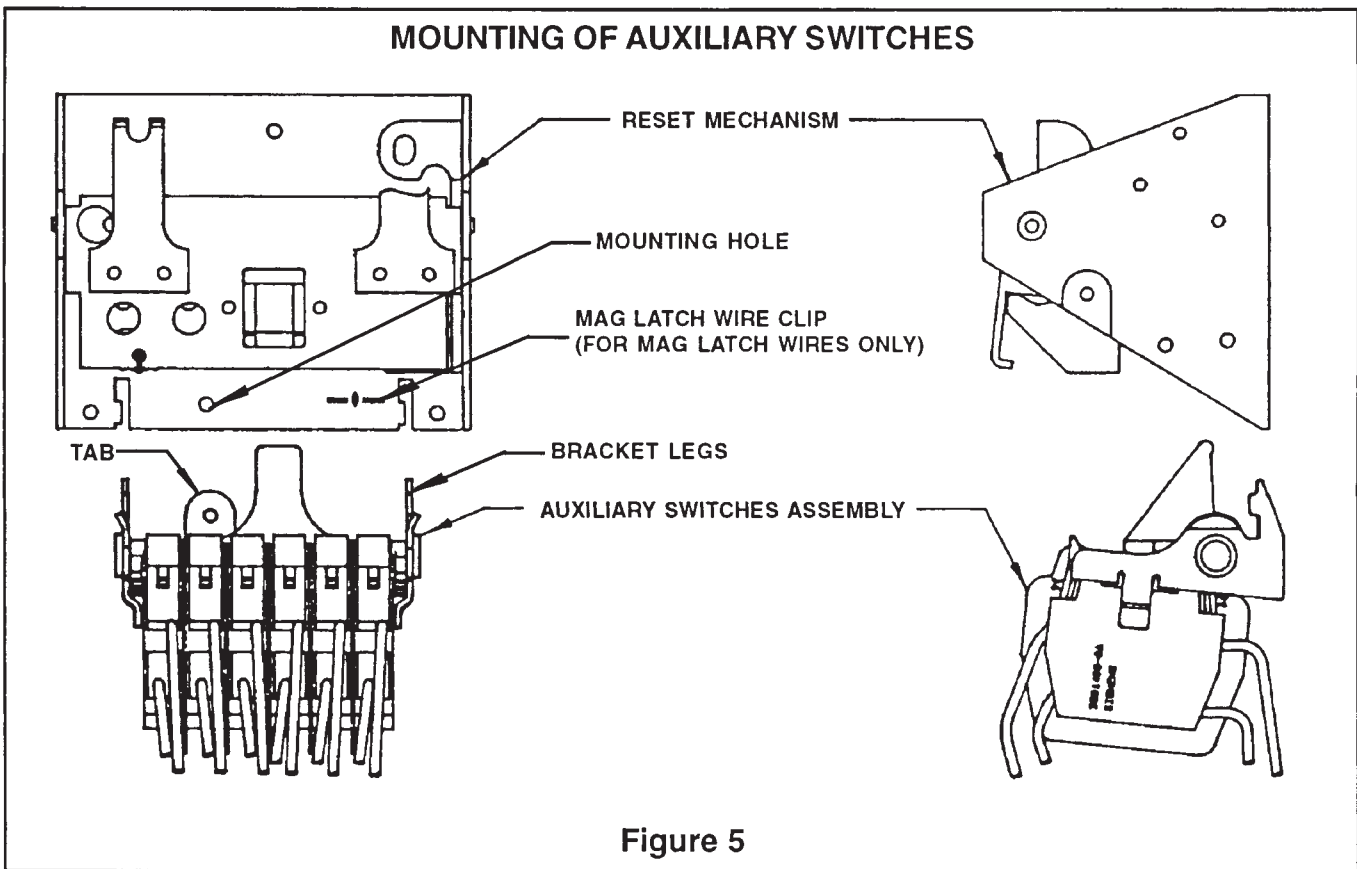
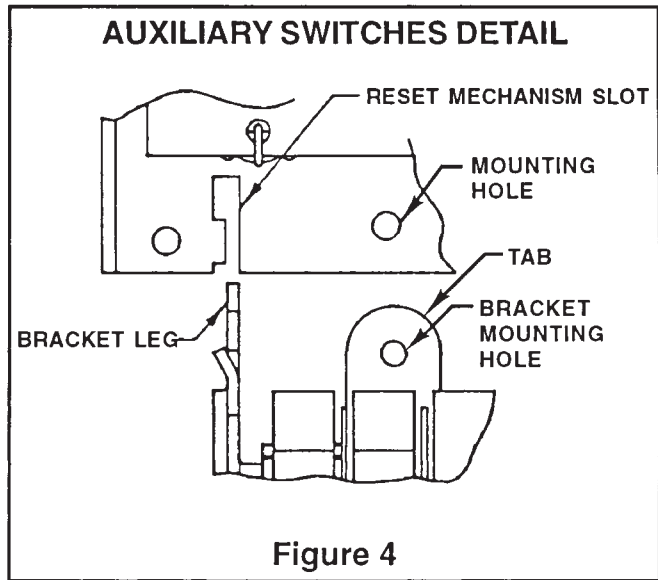

	⚠ DANGER
	Hazardous voltage. Will cause death or serious injury.
	Turn off and lock out all power supplying the device prior to cover(s) removal or while cover(s) are removed and when installing any internal or external accessory. Replace the cover(s) and shield(s) before power supplying this device is turned on.

Installation Instructions

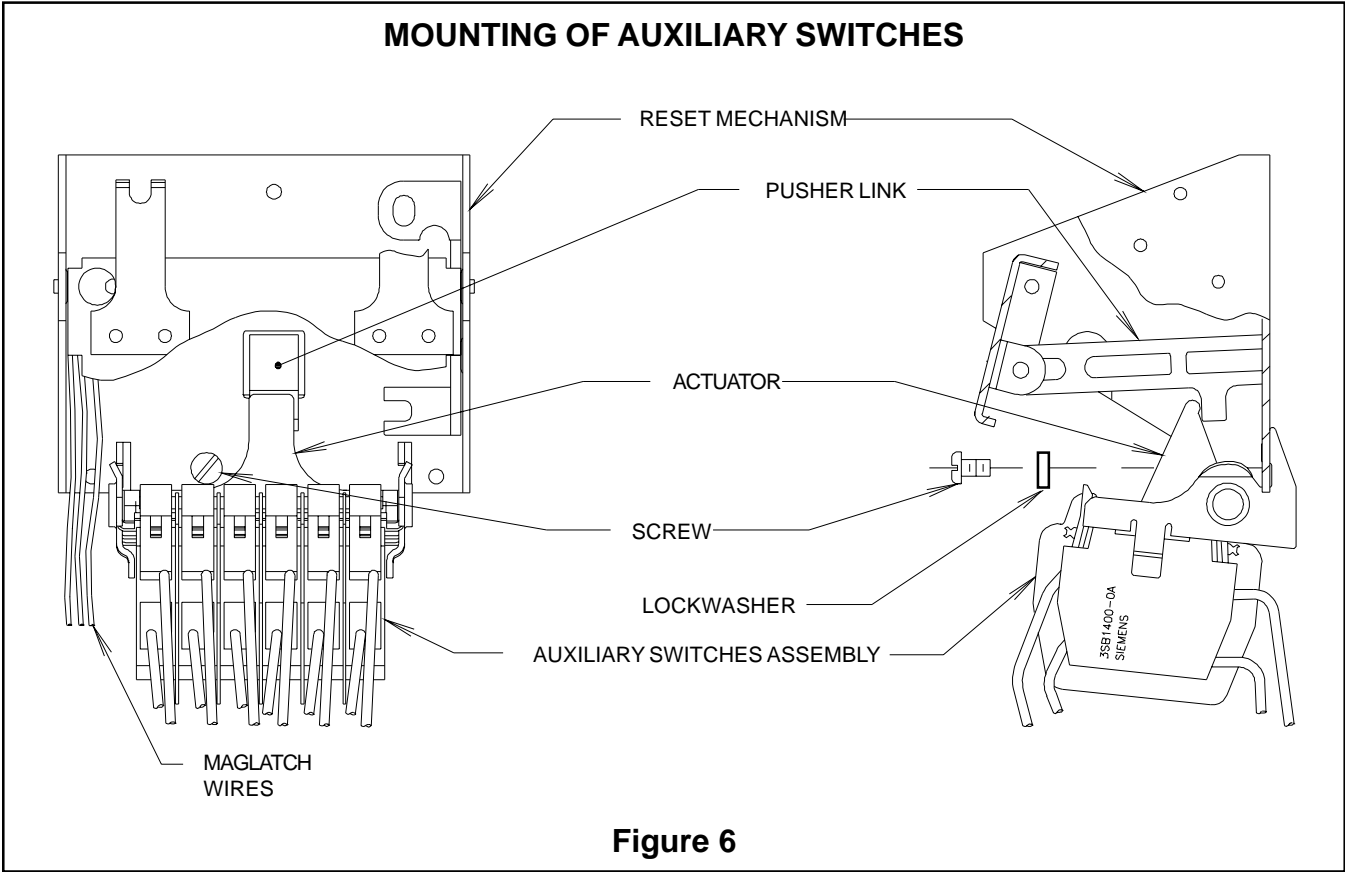

Figure 6

10. Make sure that the actuator rests on top of the pusher link (See Figure 6). Make sure no maglatch wires or other wires are routed underneath the auxiliary switch actuator.
11. Apply #271 Loctite to screw threads. Secure the assembly with the screw and lockwasher provided. Torque screw to 9-11 in-lbs.

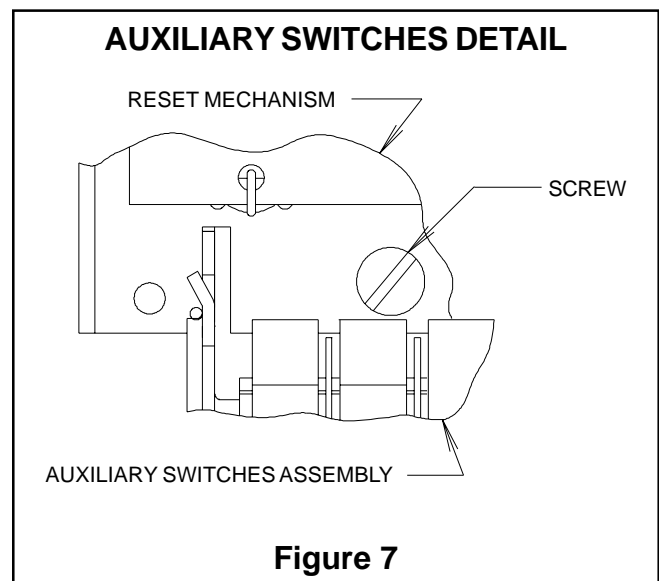
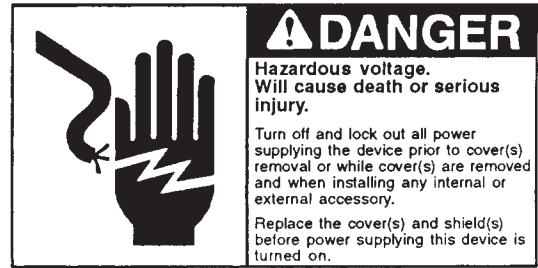
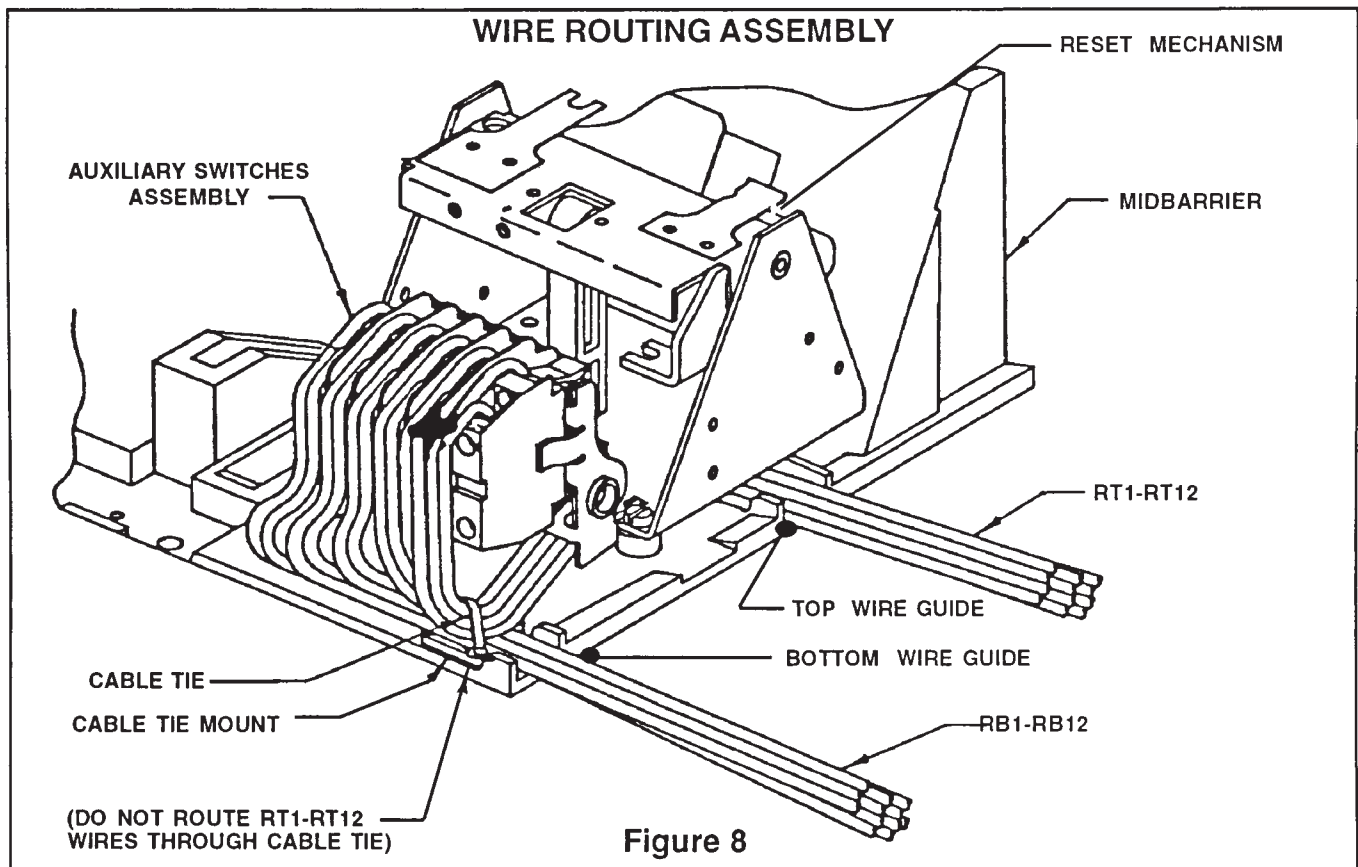

Figure 7



Installation Instructions

- 12. Add cable tie mount (See Figure 8 for location).
- 13. Route RT1-RT12 wires under the reset mechanism and out the top wire guide in the midbarrier (See Figure 8).
- 14. Route RB1-RB12 wires through the bottom wire guide in the midbarrier.
- 15. Insert cable tie into the cable tie mount. Wrap cable tie around all auxiliary switch wires. Tighten cable tie to secure wires.



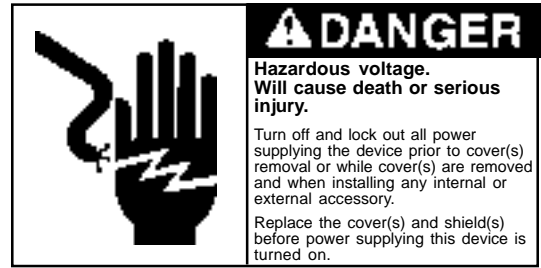

Installation Instructions

16. Replace the trip unit by pushing it onto the trip unit plug. Slide the trip unit over the support bracket pins. Secure the trip unit by replacing the mounting screw. Torque screw to 12-14 in-lbs (See Figures 2 and 3, Page 2).
17. Apply the auxiliary switches label to the side of the cover (See Figure 9). Mark the accessory label to indicate that the auxiliary switches have been installed.
18. Replace the breaker cover. Check to ensure that the wires exit the breaker through the wire guides and are not pinched by the breaker cover. Replace the 8 cover screws (See Figure 1, Page 1). Torque #10 (corner) screws to 28-32 in-lbs. Torque 1/4" screws to 68-75 in-lbs.

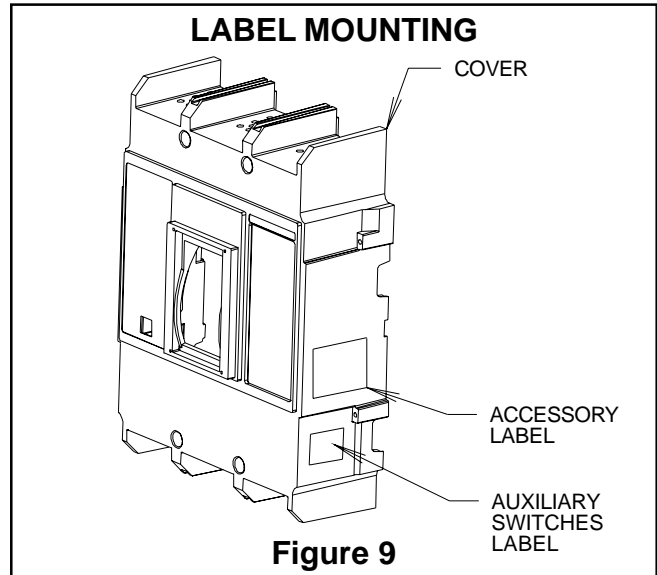

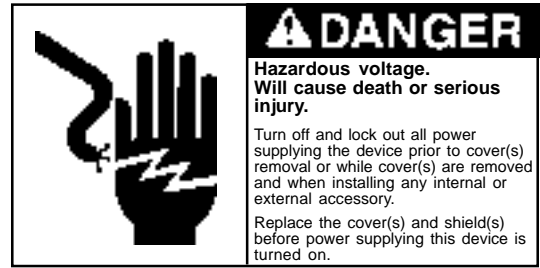

Installation Instructions

- 19. Perform electrical check by following steps a through d.
- 20. Connect the terminals to the proper terminal block locations (See Figure 8, Page 5).

ELECTRICAL CHECK

- a. With breaker in open position (main contacts open), check for continuity on "B" contacts and for no continuity on "A" contacts.
- b. Close breaker by moving the handle to the OFF position then to the ON position.
- c. Check for continuity on "A" contacts and for no continuity on "B" contacts.
- d. If the auxiliary switches do not function properly during check procedure, check for incorrect installation or wiring.

ELECTRICAL DATA FOR AUXILIARY SWITCHES

Rating Voltage	Make, Break, and Continuous Current (Amperes)	Catalog Number
60 Hz AC		
120	10	STDAS2 thru STDAS12
240	10	STDAS2 thru STDAS12
480	6	STDAS2 thru STDAS12
DC		
24	3	STDAS2 thru STDAS12
125	.5	STDAS2 thru STDAS12

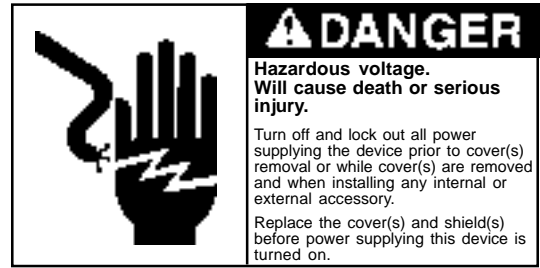

Installation Instructions

AUXILIARY SWITCHES SCHEMATIC

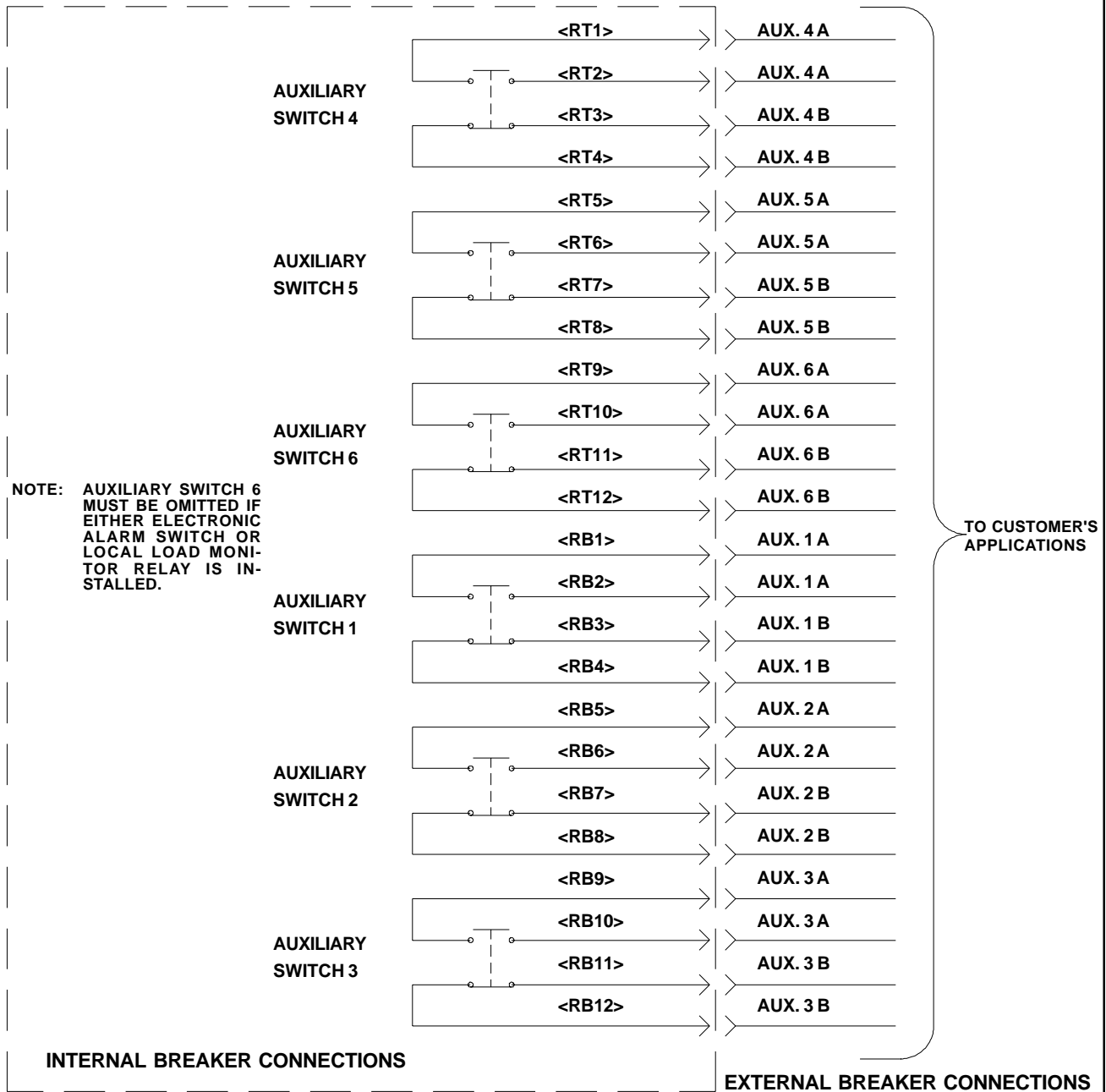

Figure 10

Installation Instructions

Trip Alarm Switches

	<p>⚠ WARNING</p> <p>Install all accessories with the breaker "Tripped."</p> <p>To avoid injury or damage to equipment, do not install accessories with breaker in a "Closed" position.</p>
---	---

Alarm Switches

Alarm switches reflect the trip status of the circuit breaker. When the mechanism is tripped due to any means, including overload, short circuit, ground fault, shunt trip, or the front panel trip button, the alarm switch changes state.

"A" or "NO" Contacts:

when mechanism is latched and "Off" or "On"Open
when mechanism if trippedClosed

"B" or "NC" Contacts:

when mechanism is latched and "Off" or "On"Open
when mechanism is trippedClosed

The auxiliary switches are installed on the left side of the mechanism.

To install the alarm switches, first remove the front cover (see page 14).

Follow these steps to install the alarm switches.



1. Slide insulating barrier onto rail.
2. Clip one switch onto rail.
3. Slide second insulating barrier onto rail.
4. Clip second switch onto rail.

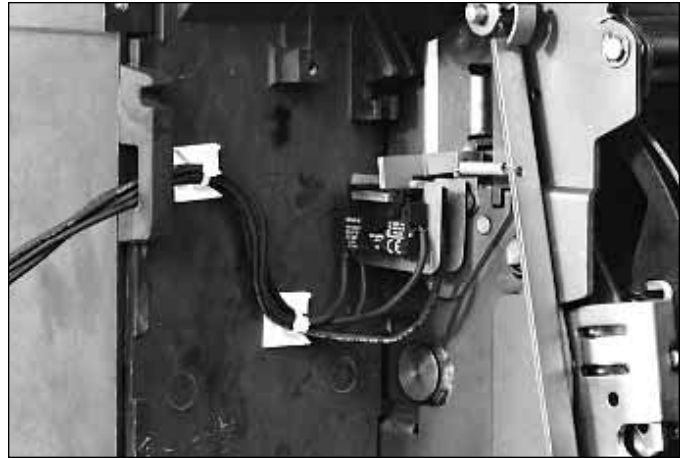

5. Install self-adhesive wire retainers and route wires as shown.
6. Connect the wires to the terminal strip according to the labels on the wires (LT1-LT4).
7. Replace the front cover.

Item: Shunt Trip Accessory

For use with: Siemens' Circuit Breakers or Molded Case Switches

Type: STD62000, STD62500, STD63200, SHTD62000, SHTD62500, SHTD63200, SHHTD62000, SHHTD62500, SHHTD63200, TD62000, TD62500, and TD63200

Cat. No.: STDST12, STDST24, STDST48, STDST120, STDST125, STDST240, STDST480

Page 1 of 9

Siemens Energy & Automation, Inc.
Bellefontaine, OH 43311 U.S.A.

Installation Instructions



⚠ DANGER

Hazardous voltage. Will cause death or serious injury.

Turn off and lock out all power supplying the device prior to cover(s) removal or while cover(s) are removed and when installing any internal or external accessory.

Replace the cover(s) and shield(s) before power supplying this device is turned on.



⚠ WARNING

Mechanical Hazard. Mechanism can cause severe injury when cover is removed.

Before removing cover trip device by pushing "Push - To - Trip" button.



SAFETY INSTRUCTIONS

NOTE: These instructions outline the recommended installation procedure.

Tools Required: 1/4" flat blade screwdriver, 1/4" screw starter (magnetic or clip), #2 phillips screwdriver, #3 phillips screwdriver.

MOUNTING OF SHUNT TRIP ASSEMBLY

- Accessory installation should be completed before the breaker is mounted and connected. **If the breaker is installed turn off and lock out all power supplying the circuit breaker prior to cover removal or while cover is removed.** For ease of installation, it is highly recommended that the breaker be disconnected and removed from the panel or the enclosure.

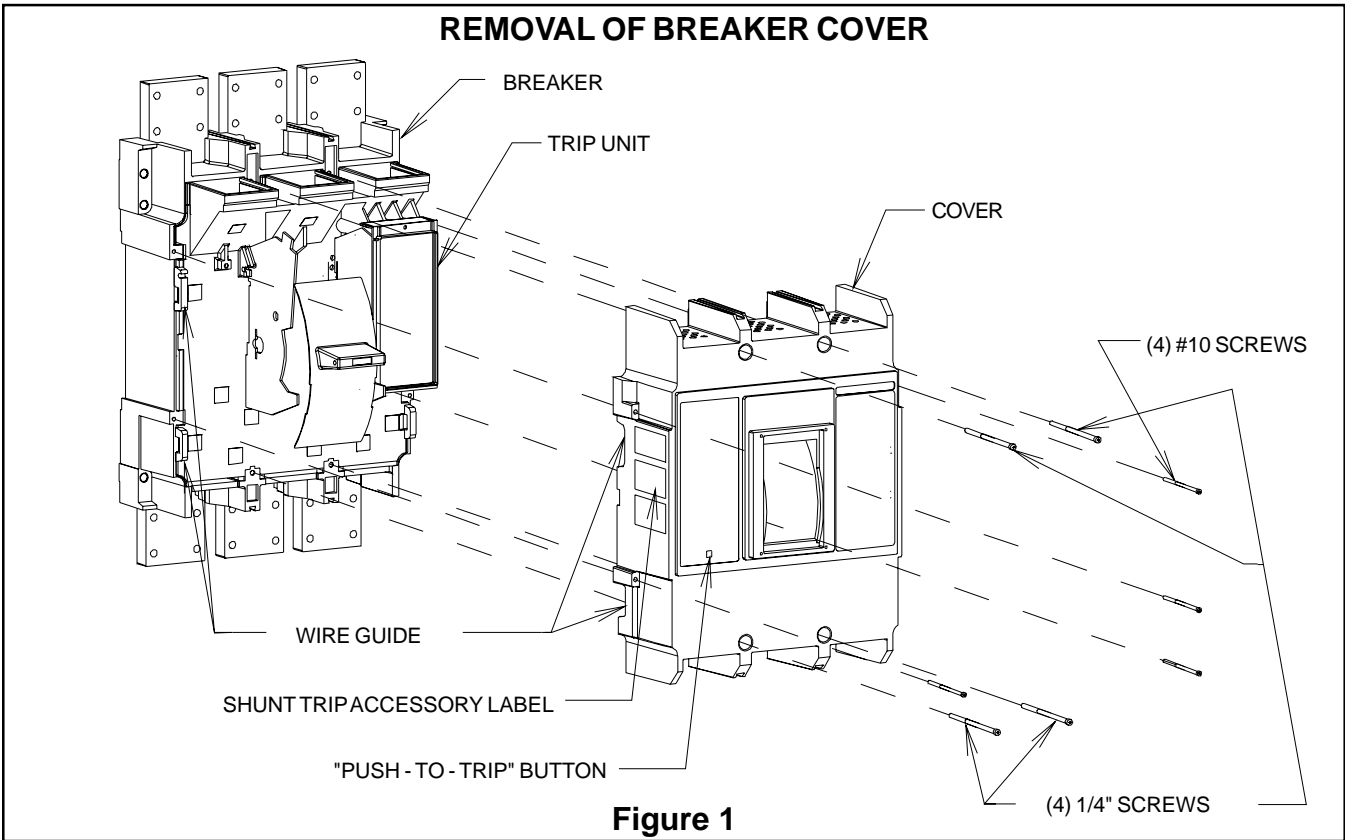

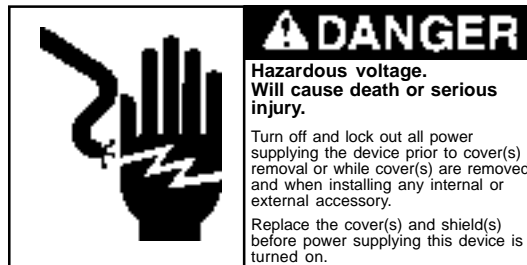

Installation Instructions

2. Trip breaker by pushing the "Push-to-Trip" button.
3. To install the shunt trip assembly the breaker cover and trip unit must first be removed.
4. Remove the breaker cover by removing the (4) #10 Phillips head screws at the corners and the (4) 1/4" Phillips head screws in recesses of the cover (See Figure 1, Page 1).
5. Remove the trip unit retaining screw (See Figure 2).
6. Slide the trip unit up to clear the support bracket pins (See Figure 2).
7. Remove the trip unit by pulling it off the trip unit plug (See Figure 3).

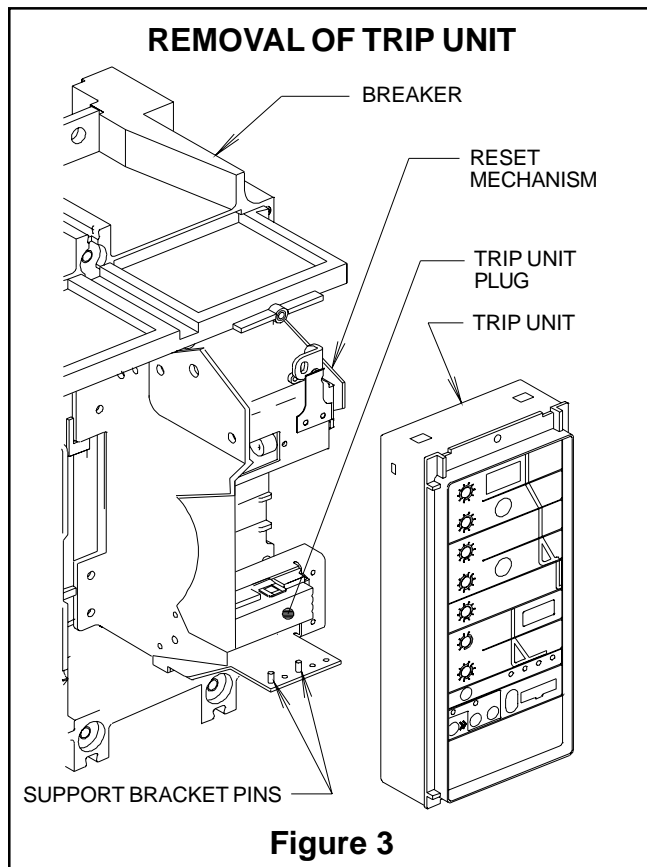
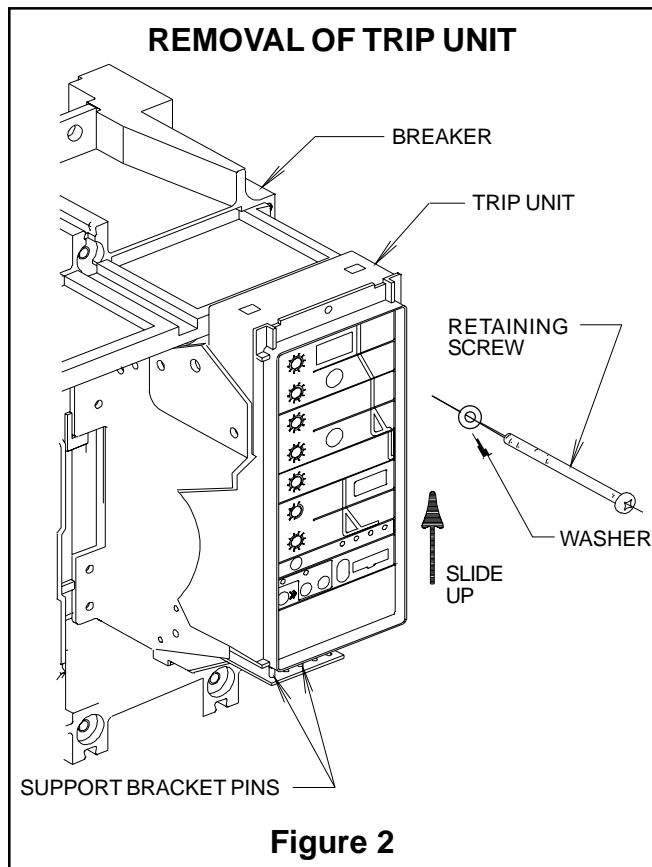

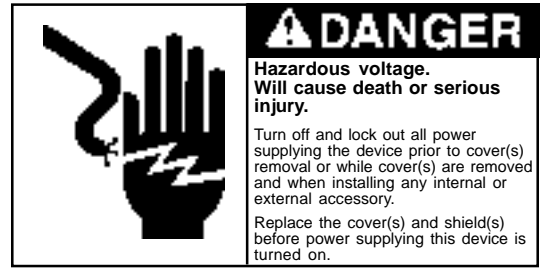

Installation Instructions

- After the breaker cover and trip unit are removed locate the reset mechanism (See Figure 4, below, and Figure 3, Page 2).
- Remove the rubber band from the shunt trip assembly. Be careful not to drop and damage the plunger.

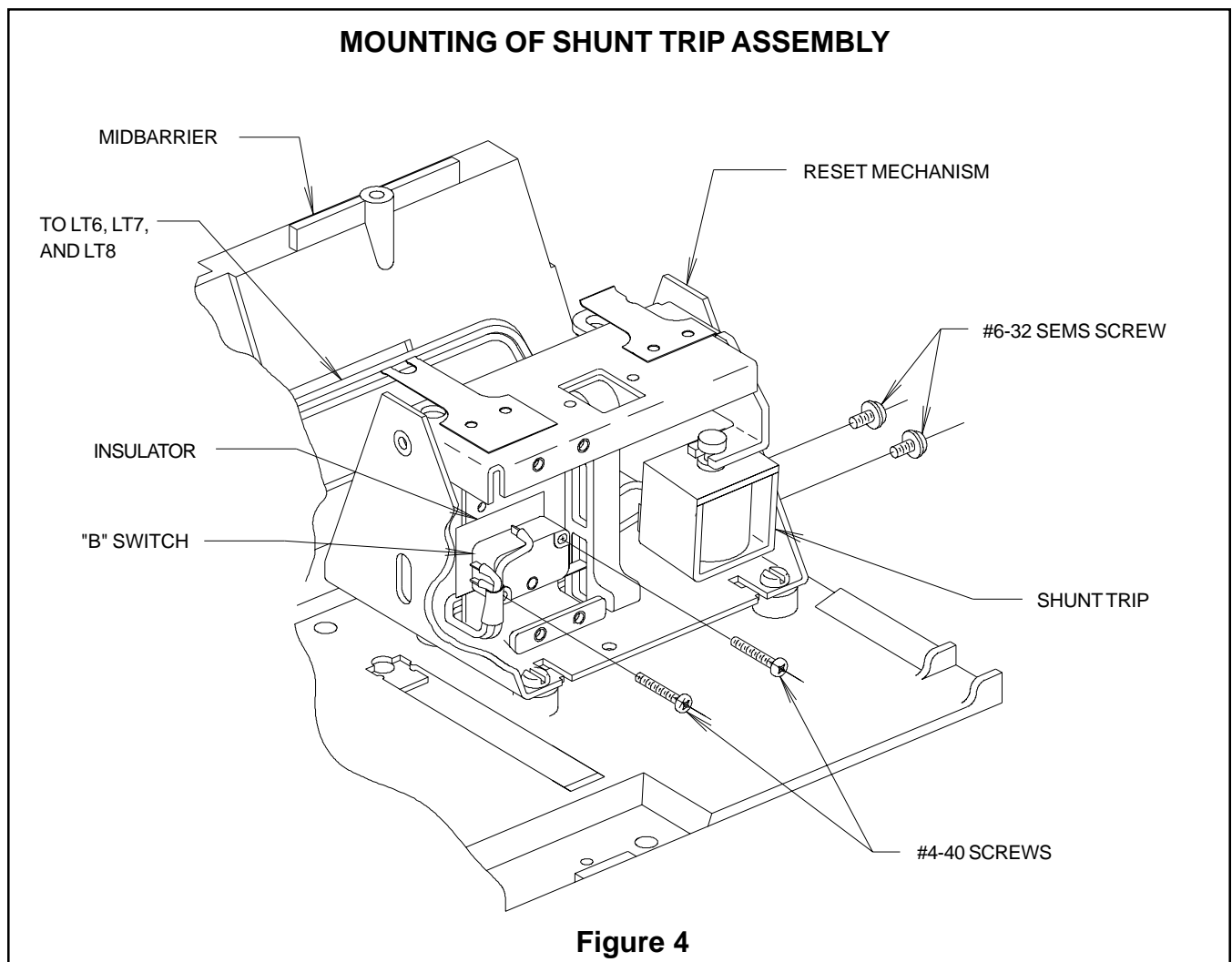

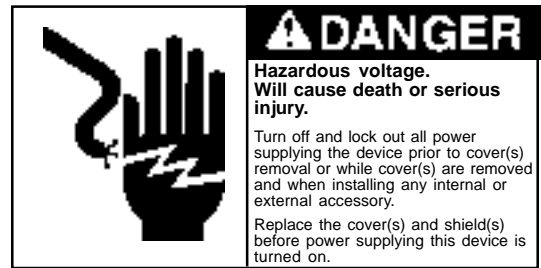

Installation Instructions

10. Align the shunt trip solenoid on the reset mechanism. Make sure that the secondary latch is positioned inside the groove of the solenoid plunger (See Figure 5).
11. Secure the shunt trip solenoid with the two #6-32 screws provided (See Figure 5). Apply Loctite #271 to screw threads. Torque screws to 9-11 in-lbs.
12. Check the plunger for binding after the screws are tightened. The plunger should move freely when the secondary latch is moved. If the plunger binds, loosen the screws, adjust the solenoid and re-tighten the screws. Repeat as necessary until the plunger moves freely.

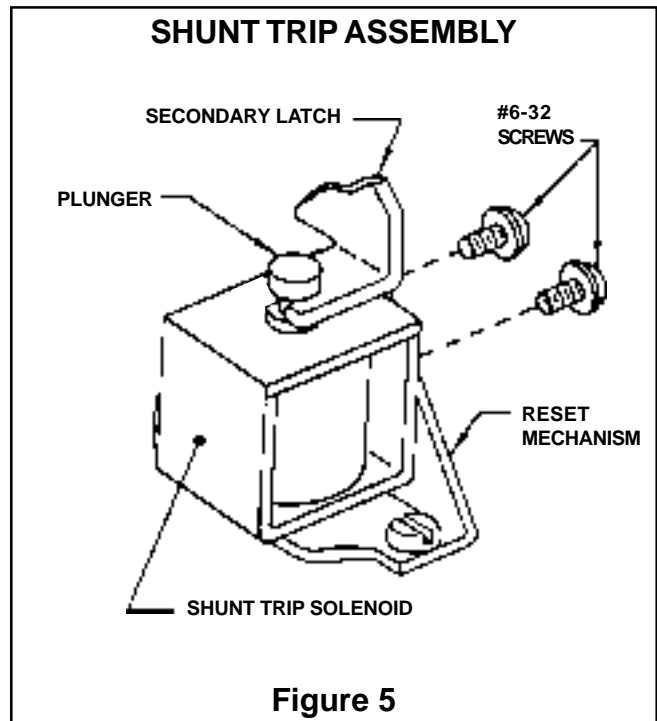

13. Carefully remove the Trip Spring(s) from the reset mechanism. Do not bend nor nick the Trip Spring(s). (See Figure 7). To mount the "B" Switch, first make sure that the switch lever is inside the bottom cavity of the pusher link (See Figure 6).
14. Make sure that the switch lever rests on the pusher link, as shown in Figure 6, when the breaker main contacts are open.
15. Place insulator between the "B" Switch and the Switch Mounting Bracket, then secure the "B" Switch with the two #4-40 screws to the bottom holes on the switch mounting bracket. Apply #271 Loctite to screw threads (See Figure 6).

NOTE: Torque screws to 5-6 in-lbs. Carefully reinstall the Trip Spring(s) onto the reset mechanism. Attach spring(s) as shown in Figures 6 & 7. Do not bend nor nick spring(s).

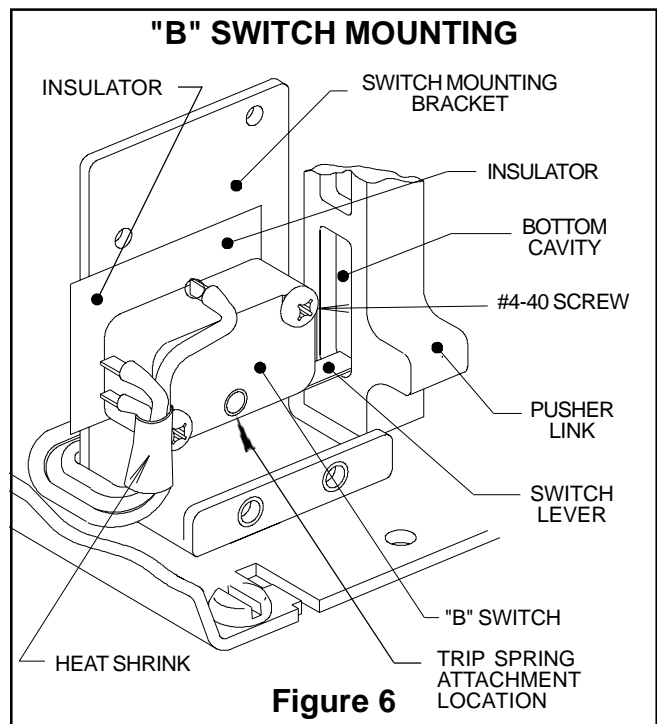

	⚠ DANGER
	Hazardous voltage. Will cause death or serious injury.
	Turn off and lock out all power supplying the device prior to cover(s) removal or while cover(s) are removed and when installing any internal or external accessory. Replace the cover(s) and shield(s) before power supplying this device is turned on.

Installation Instructions

- 16. After the "B" switch and the shunt trip solenoid are secured, route wires into the wire clip (See Figure 7). Make sure that wires fit inside the wire clip and do not interfere with the pusher link.

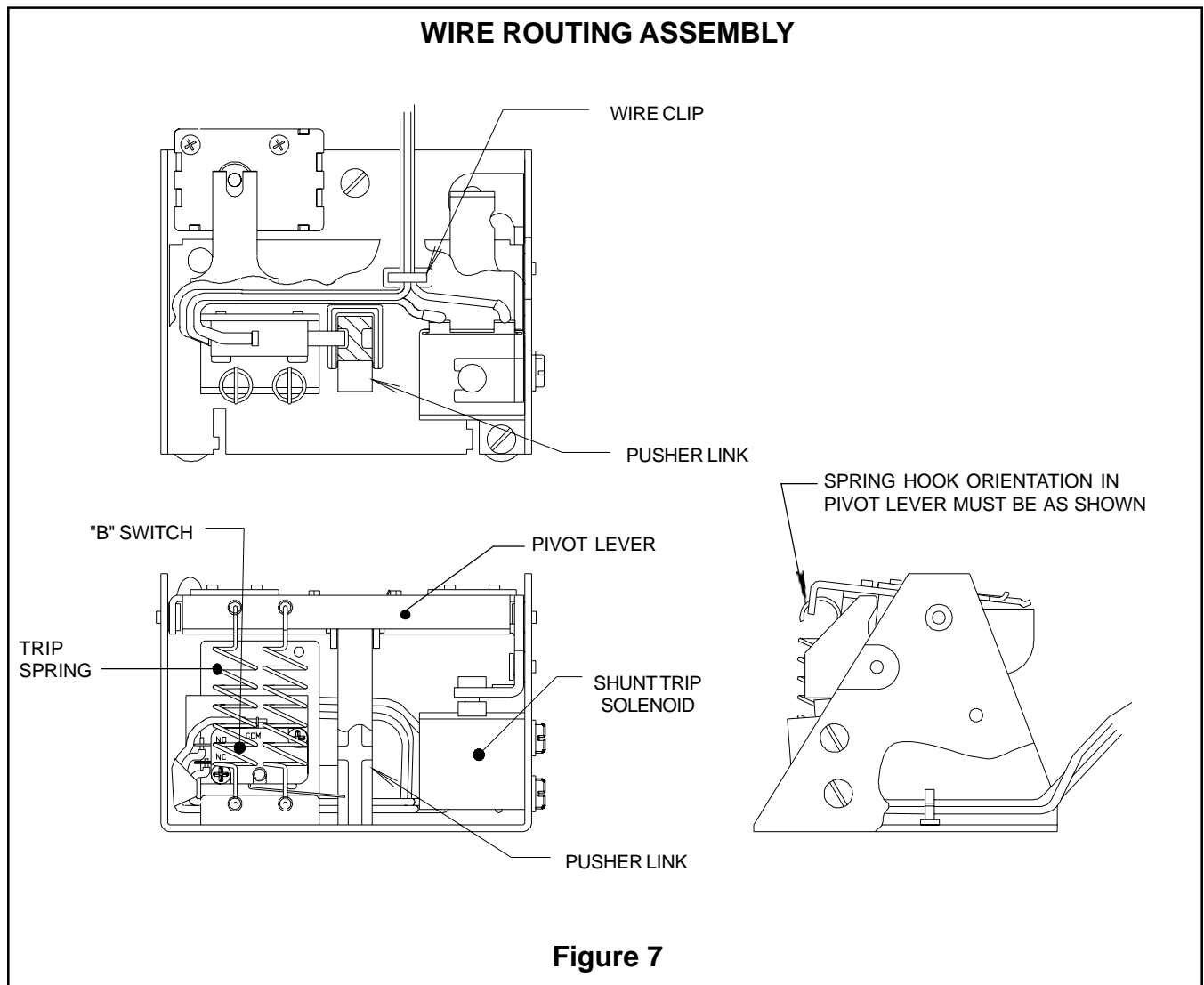

	⚠ DANGER
	Hazardous voltage. Will cause death or serious injury.
	Turn off and lock out all power supplying the device prior to cover(s) removal or while cover(s) are removed and when installing any internal or external accessory. Replace the cover(s) and shield(s) before power supplying this device is turned on.

Installation Instructions

- 17. Add first and second cable tie mount and cable tie to midbarrier (See Figure 8). Do not tighten cable ties until the shunt trip installation is completed.

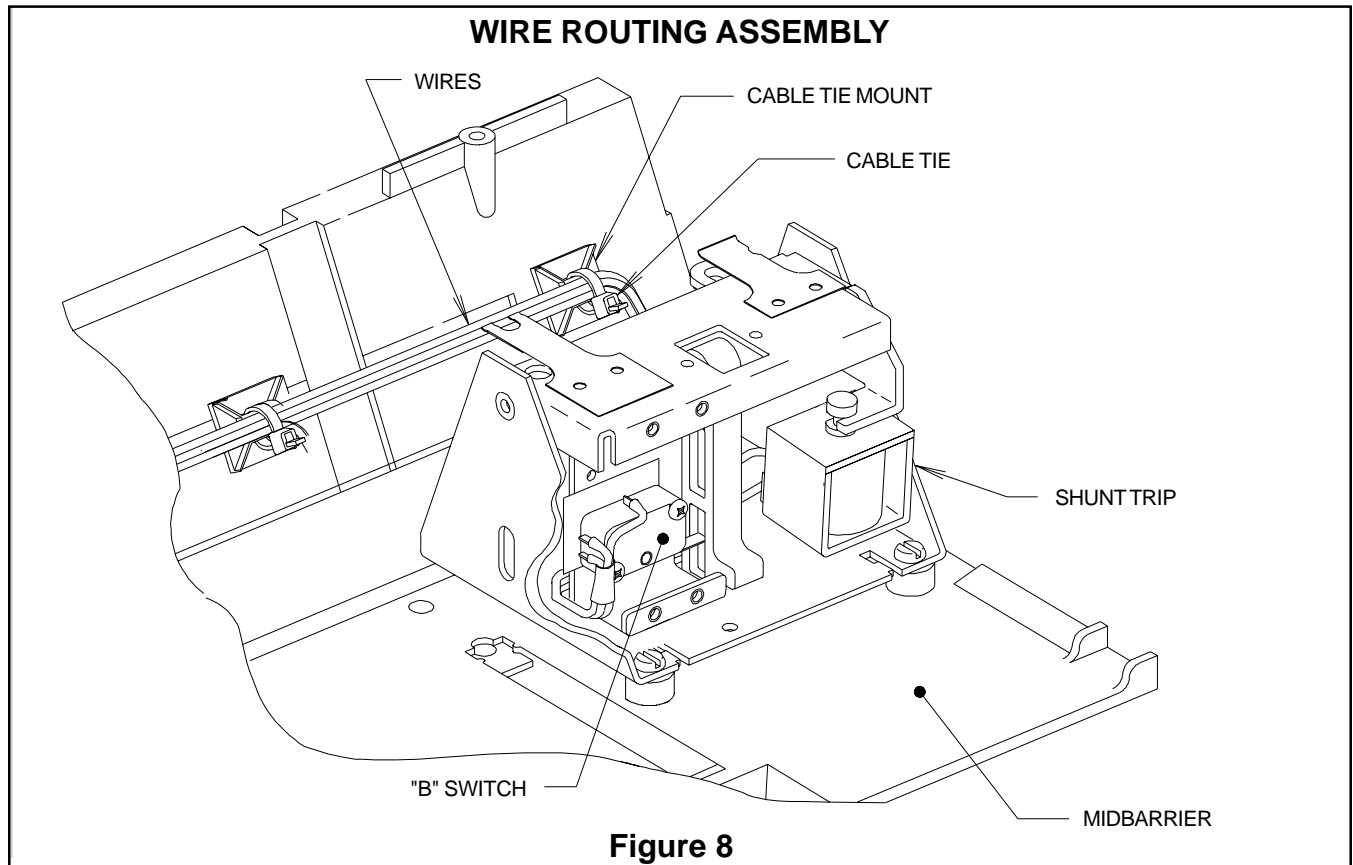

	⚠ DANGER
	Hazardous voltage. Will cause death or serious injury.
	Turn off and lock out all power supplying the device prior to cover(s) removal or while cover(s) are removed and when installing any internal or external accessory. Replace the cover(s) and shield(s) before power supplying this device is turned on.

Installation Instructions

- 18. Add third and fourth cable tie mount and cable tie (See Figure 10).
- 19. Route wires through the wire guide on the midbarrier (See Figure 9).
- 20. Eliminate excess slack in wires. Tighten cable ties.
- 21. Replace the trip unit by pushing it onto the trip unit plug. Slide the trip unit over the support bracket pins. Secure the trip unit by replacing the mounting screw. Torque screw to 12-14 in-lbs (See Figures 2 and 3, Page 2).
- 22. Apply the shunt trip accessory label to the left side of the breaker cover (See Figure 1, Page 1). Mark the accessory label on the right side of the cover to indicate that the shunt trip has been installed.

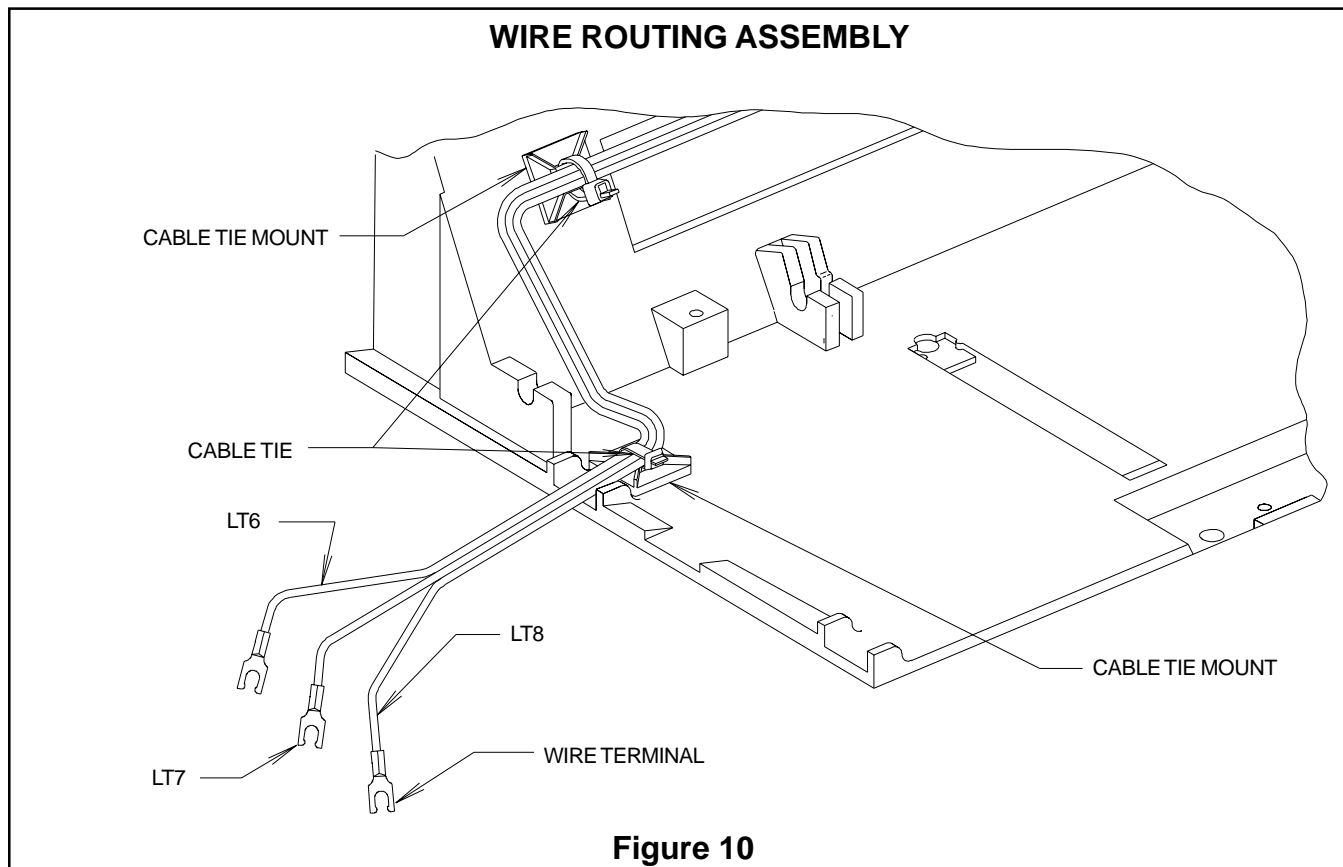
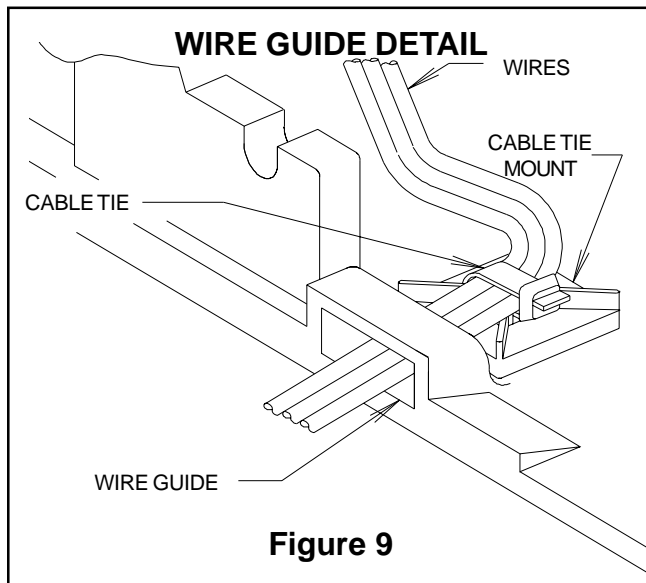

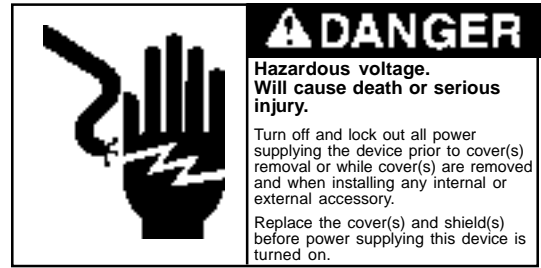

Installation Instructions

- 23. Replace the breaker cover. Check to ensure that wires exit the breaker through the wire guide and are not pinched by the breaker cover. Replace the 8 cover screws (See Figure 1, Page 1). Torque #10 (corner) screws to 28-32 in-lbs. Torque 1/4" screws to 68-75 in-lbs.
- 24. Perform electrical check by following steps a through d.
- 25. Connect the terminals to the proper terminal block locations (See Figure 10, Page 7).

ELECTRICAL CHECK

- a. Close breaker by moving the handle to the OFF position then to the ON position.
- b. Attach test circuit to accessory leads (See Figure 11, Page 9). Apply 55 percent of the rated coil voltage for AC circuits and apply 75 percent of rated coil voltage for DC circuits. The circuit breaker should trip (main contacts should open).
- c. With the circuit breaker main contacts open, check to make sure coil circuit has opened. Check to make sure open/close indicator circuit is closed.
- d. If the shunt trip does not function properly during check procedures, check for incorrect installation or wiring.

ELECTRICAL DATA FOR SHUNT TRIP

Coil Voltage	In-rush Current (Amperes)	Catalog Number
60 Hz AC		
120	8.60	STDST120
240	5.10	STDST240
480	0.42	STDST480
DC		
12	2.80	STDST12
24	2.70	STDST24
48	1.45	STDST48
125	0.60	STDST125

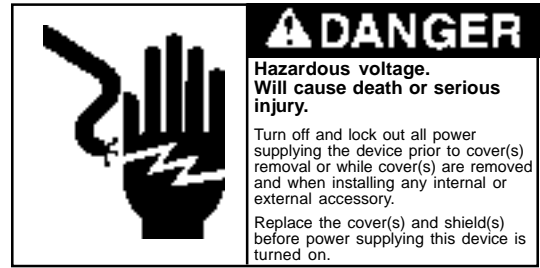

Installation Instructions

SHUNT TRIP SCHEMATIC

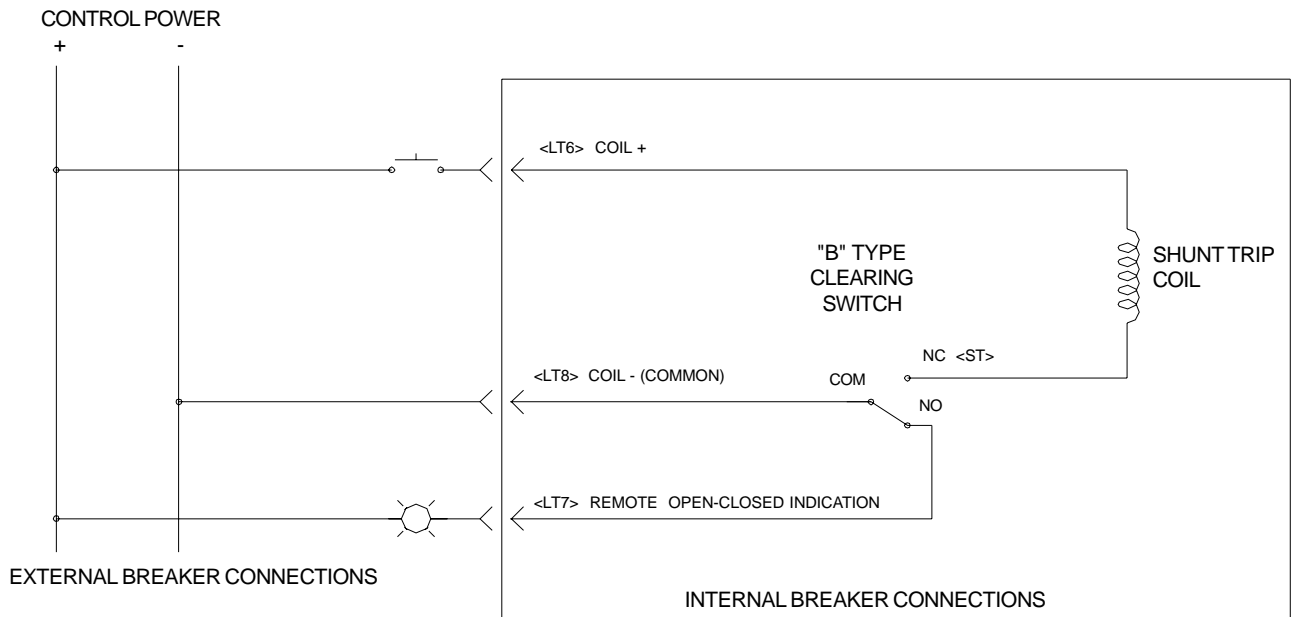

NOTE: SWITCH SHOWN WITH BREAKER MAIN CONTACTS OPEN

Figure 11

Installation Instructions

Shunt Trip



⚠ WARNING
Install all accessories with the breaker "Tripped."
To avoid injury or damage to equipment, do not install accessories with breaker in a "Closed" position.

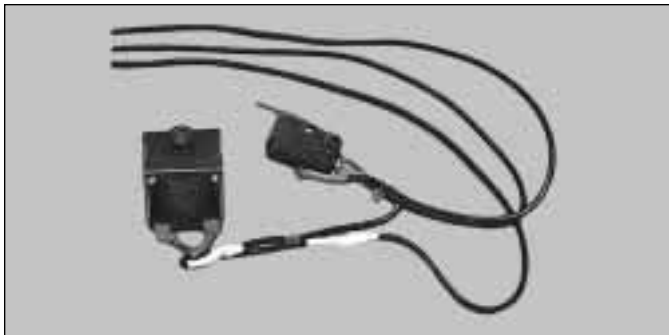

Shunt Trip Kit

The shunt trip provides the capability to open the STD Frame breaker from a remote location. Shunt trips are available to operate with a source power of 120, 240, or 480V AC, 12, 24, 48, or 125V DC. The shunt trip accessory kit consists of a trip solenoid to open the breaker, a clearing switch to remove voltage from the solenoid coil upon the breaker's opening, and mounting hardware.

To install shunt trip, first remove the breaker front cover and trip unit (see pages 12-14).

1. Remove the rubber band from the shunt trip assembly. Be careful not to drop and damage the plunger.

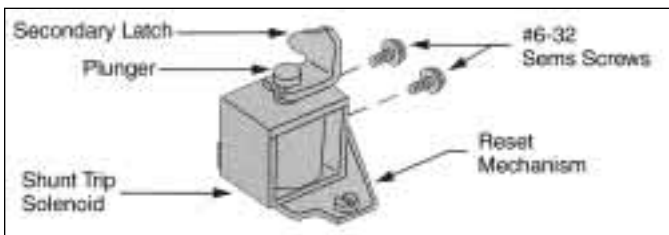

Figure 1. Aligning and Securing the Shunt Trip Solenoid

2. Align the shunt trip solenoid on the reset mechanism. Make sure that the secondary latch is positioned inside the groove of the solenoid plunger (Figure 1).
3. Secure the shunt trip solenoid with two #6-32 SEMS screws provided (Figure 1). Torque screws 9 to 11 in-lbs.
4. Check the plunger for binding after the screws are tightened. The plunger should move freely when the secondary latch is moved.

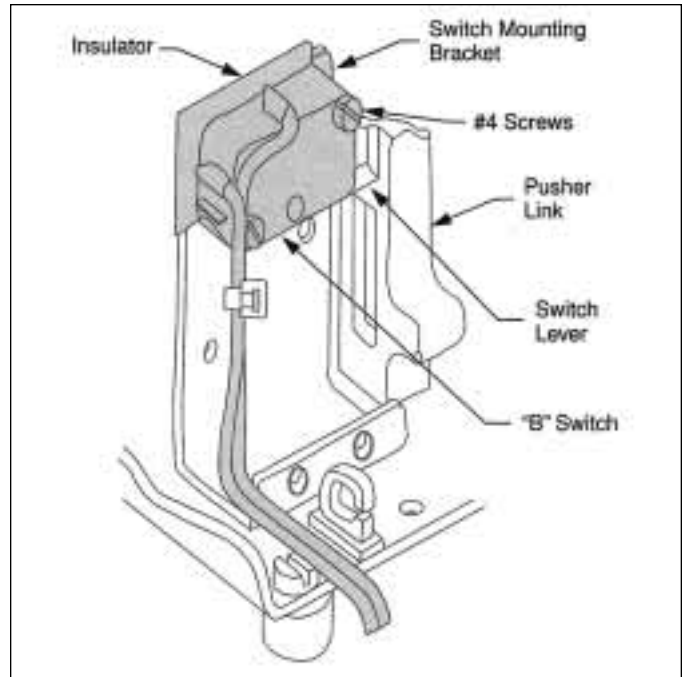

Figure 2. Mounting the Clearing ("B") Switch

5. To mount the clearing ("B") switch, first make sure that the switch lever is inside the bottom cavity of the pusher link (Figure 2).
6. Place insulator between "B" switch and switch mounting bracket, then secure the "B" switch with two #4-40 screws to the bottom holes on the switch mounting bracket.

NOTE: Torque screws 5 to 6 in-lbs.

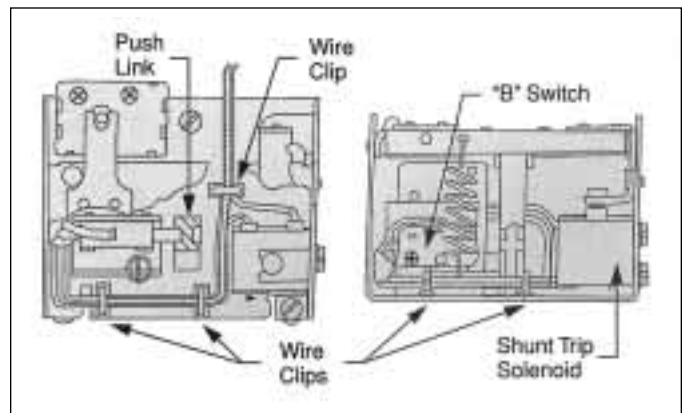

Figure 3. Routing Wires into the Wire Clips

7. After the "B" switch and the shunt trips solenoid are secured, route wires into the three wire clips (Figure 3) Make sure that wires fit inside the wire clips and do not interfere with the pusher link.

Installation Instructions

Shunt Trips

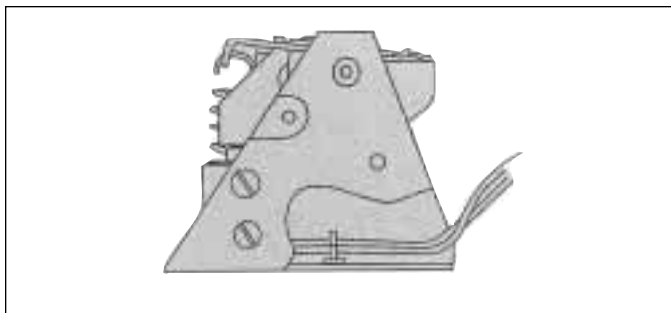

Figure 4. Routing of Wires

8. Route all wires between wire shield and mid-barrier. Make sure to route the wires toward the bottom of the trough, so that the wires fit into the mid-barrier trough (Figure 4).

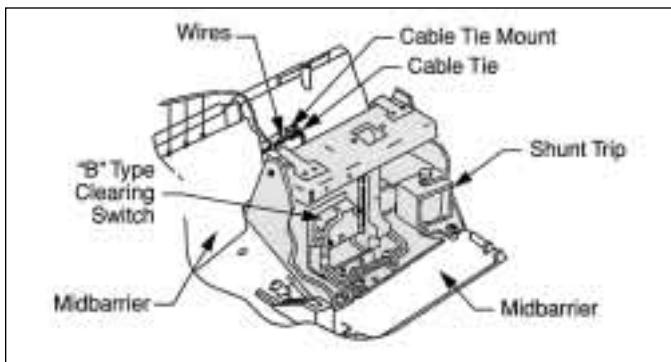

Figure 5. Location of Cable Tie Mounts and Cable Tie

9. Add cable tie mounts and cable tie as directed in accessory instructions (Figure 5).
10. Replace trip unit and breaker front cover (pages 13-14), being careful not to pinch wire leads routed to secondary disconnects or terminal block.

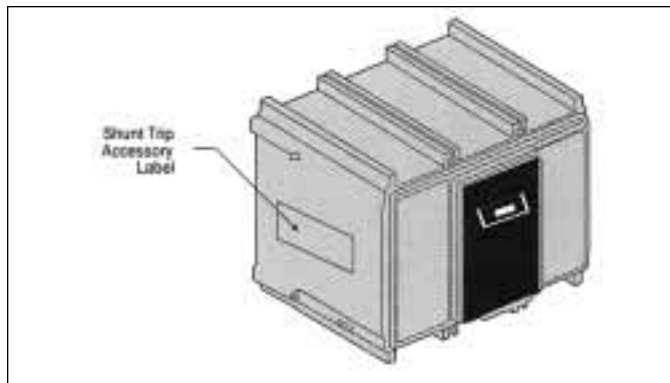

Figure 6. Location of Shunt Trip Accessory Label

11. Apply shunt trip accessory label to side of the breaker cover (Figure 6). Mark the label that is on the opposite side of the cover to indicate that the shunt trip has been installed.

Installation Instructions

Shunt Trip Schematic Layout



⚠ WARNING

Install all accessories with the breaker "Tripped."
To avoid injury or damage to equipment, do not install accessories with breaker in a "Closed" position.

Shunt Trip Ratings

Catalog Number	Hold-in Current (Amperes)	Operating Voltage
DST12	2.50A	12V DC
DST24	20.00A	24V DC
DST48	10.30A	48V DC
DST125	3.60A	125V DC
DST120	9.40A	120V AC
DST240	0.41A	240V AC
DST480	0.35A	480V AC

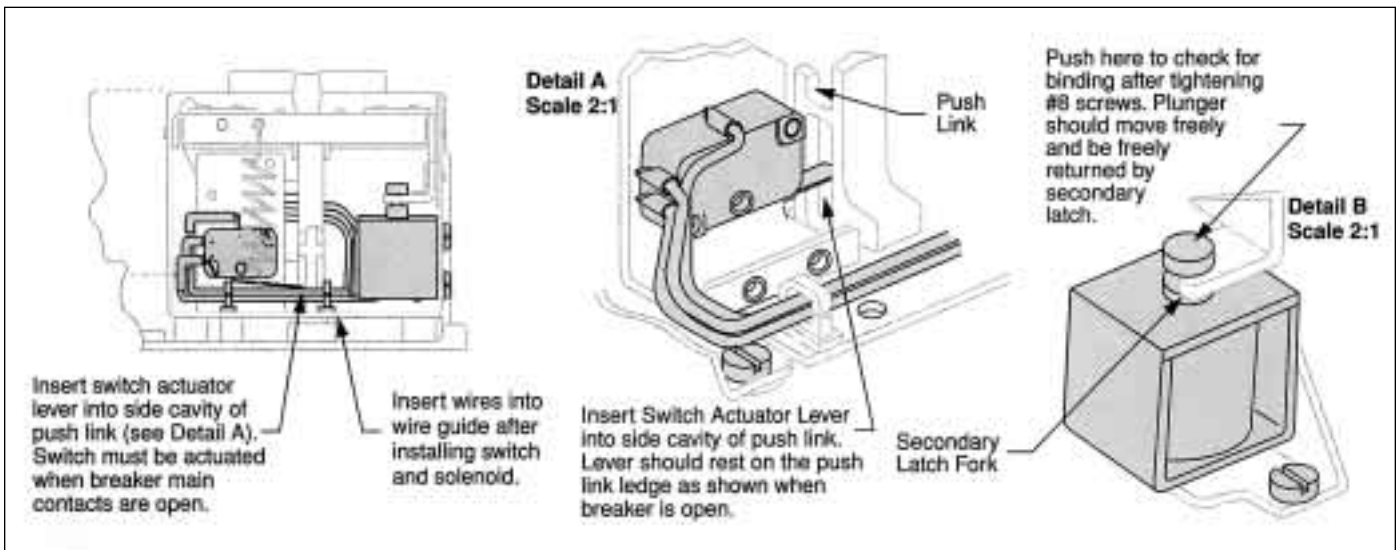
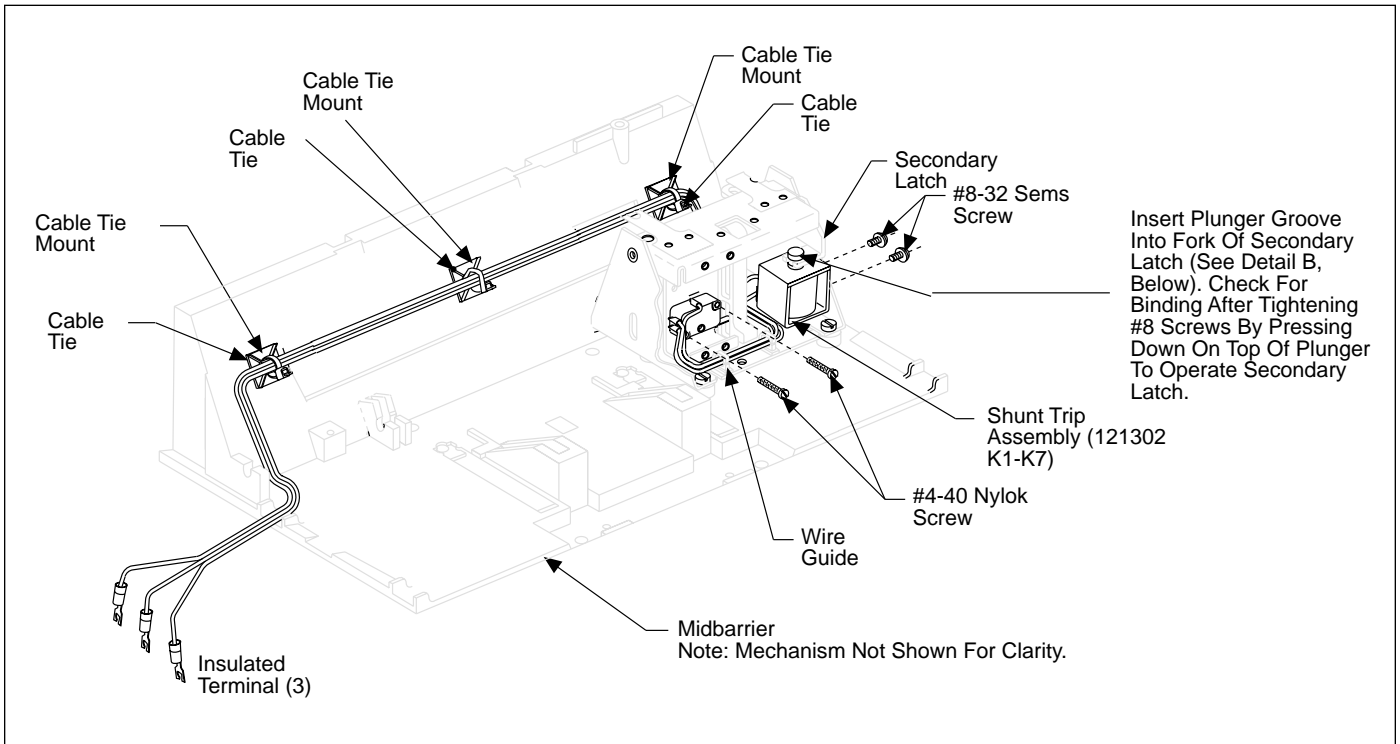

Shunt Trip Installation

Installation Instructions

⚠ DANGER

Hazardous voltage. Will cause death or serious injury.

Turn off and lock out all power supplying the device prior to cover(s) removal or while cover(s) are removed and when installing any internal or external accessory.

Replace the cover(s) and shield(s) before power supplying this device is turned on.

⚠ WARNING

Mechanical Hazard. Mechanism can cause severe injury when cover is removed.

Before removing cover trip device by pushing "Push - To - Trip" button.

SAFETY INSTRUCTIONS

NOTE: These instructions outline the recommended installation procedure.

MOUNTING OF BELL ALARM OR DISPLAY MODULE RELAY

- Accessory installation should be completed before the breaker is mounted and connected. **If the breaker is installed turn off and lock out all power supplying the circuit breaker prior to cover removal or while cover is removed.** For ease of installation, it is highly recommended that the breaker be disconnected and removed from the panel or the enclosure.

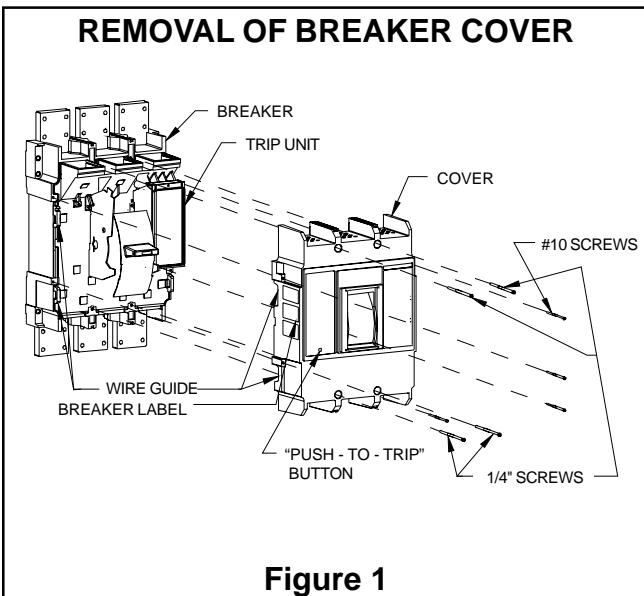

Table 1		
STDBAxxx		
Electronic Bell Alarm works with Trip Unit Cat. No.		
STD20TLI	STD25TLI	STD32TLI
STD20TLS	STD25TLS	STD32TLS
STD20TLSI	STD25TLSI	STD32TLSI
STD20TLIG	STD25TLIG	STD32TLIG
STD20TLSG	STD25TLSG	STD32TLSG
STD20TLSIG	STD25TLSIG	STD32TLSIG
STD20TMLI	STD25TMLI	STD32TMLI
STDDMRxxx		
Display Module Relay works with Trip Unit Cat. No.		
STD20TLI	STD25TLI	STD32TLI
STD20TLS	STD25TLS	STD32TLS
STD20TLSI	STD25TLSI	STD32TLSI
STD20TLIG	STD25TLIG	STD32TLIG
STD20TLSG	STD25TLSG	STD32TLSG
STD20TLSIG	STD25TLSIG	STD32TLSIG



⚠ DANGER

Hazardous voltage.
Will cause death or serious injury.

Turn off and lock out all power supplying the device prior to cover(s) removal or while cover(s) are removed and when installing any internal or external accessory.

Replace the cover(s) and shield(s) before power supplying this device is turned on.

Installation Instructions

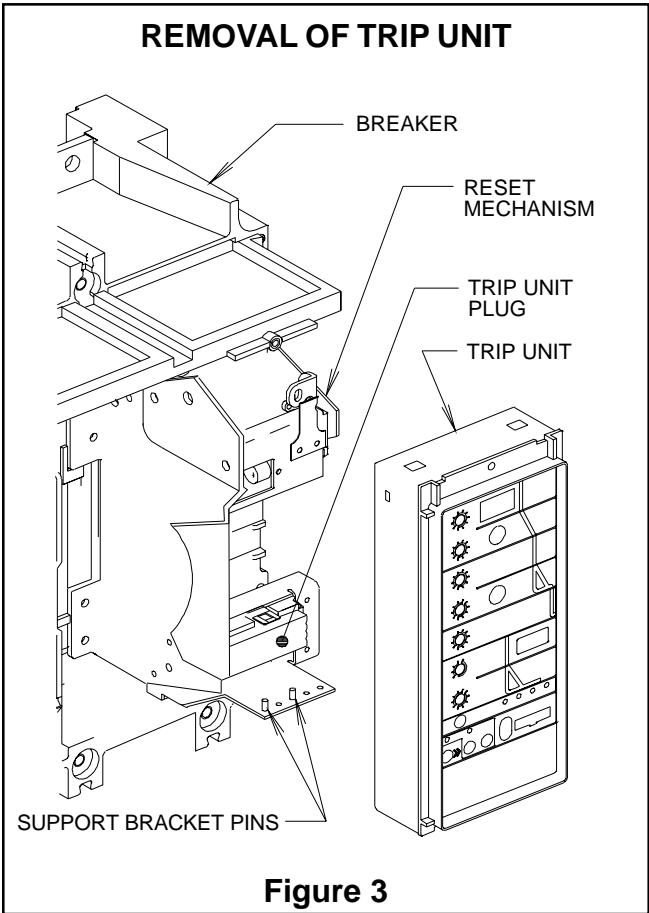
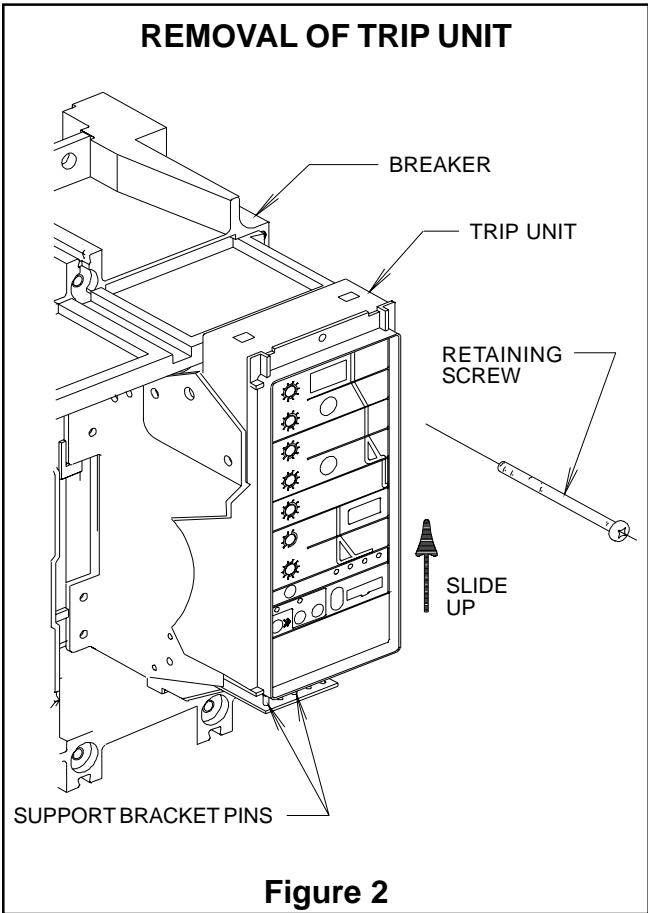

Breaker Wiring

1. Trip breaker by pushing the "Push-to-Trip" button.
2. Remove the breaker cover by removing the (4) #10 Phillips head screws at the corners and the (4) 1/4" Phillips head screws in recesses of the cover (See Figure 1, Page 1).
3. Remove the trip unit retaining screw (See Figure 2).
4. Slide the trip unit up to clear the support bracket pins (See Figure 2).
5. Remove the trip unit by pulling it off the trip unit plug (See Figure 3).

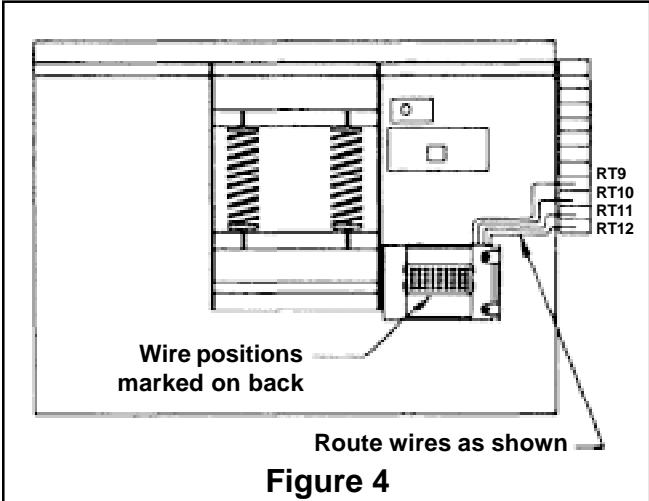



Installation Instructions

6. With a small screwdriver press in the tab on the right side of the 36-pin trip unit plug and release it from the mounting bracket. Connect the 2 short wires on this accessory to the trip unit 36-pin plug. The wire labeled #22 connects to pin hole #22 and the other wire, which is not labeled, connects to pin #1 for the Electronic Bell Alarm or pin #4 for the Display Module Relay. Route wires under the reset mechanism and out the top wire guide in the midbarrier. Connect wires labeled RT9 through RT12 to the Right Top Terminal Block as marked. Refer to Figures 3 and 4, Page 2, and Figure 5 for wiring connections and routing. Snap the 36-pin plug back into the bracket, taking care to orient it properly.
7. Mount the Bell Alarm or Display Module Relay to the trip unit bracket as shown in Figure 6, Page 4, with 2 screws and lockwashers that are provided.
8. Bundle wires using the wire ties provided and route them as shown in Figure 4, Page 2.
9. Replace trip unit by pushing it onto the trip unit plug. Slide trip unit over the support bracket pins. Secure the trip unit by replacing the mounting screw. Torque screw to 6-8 in-lbs (See Figures 2 and 3, Page 2).
10. Replace the breaker cover. Check to ensure that wires exit the breaker through the wire guide and are not pinched by the breaker cover. Replace the 8 cover screws (See Figure 1, Page 1). Torque #10 (corner) screws to 28-32 in-lbs. Torque 1/4" screws to 68-75 in-lbs.
11. Apply label to left side of circuit breaker cover.

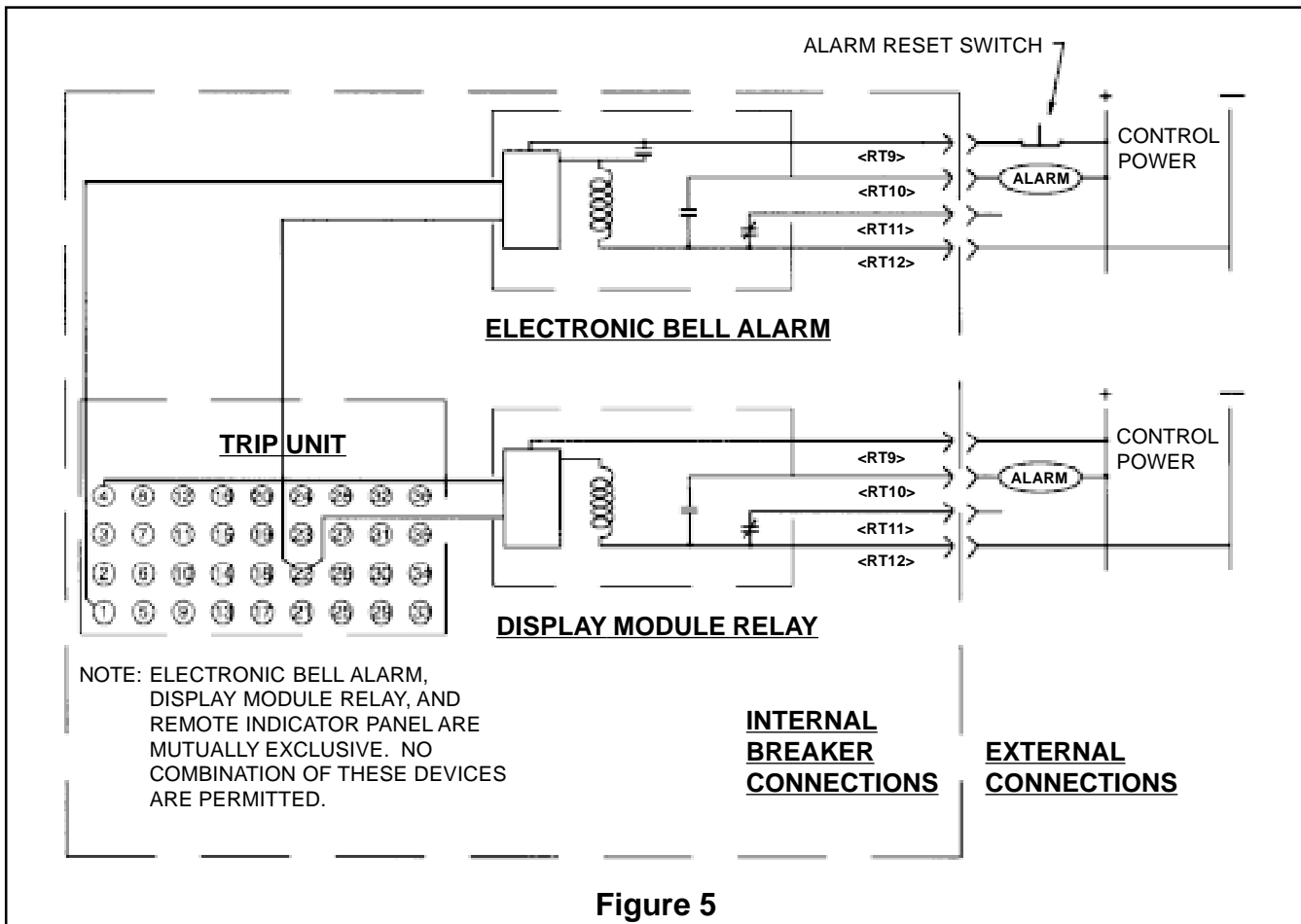

Figure 5



Installation Instructions

<u>Hardware List:</u>	<u>Quantity</u>
MOUNTING SCREWS	2
LOCKWASHER	2
WIRE TIES	3
LABEL, BREAKER ACCESSORY	1

WIRING

All external wiring beyond the terminal block (See Figure 5, Page 3) must be 18 AWG. This accessory is available in four different control power ratings: 24VDC, 48VDC, 125VDC, and 120VAC. Connect the correct control power to terminals RT9 and RT12 using the correct polarity as shown in Figure 5, Page 3.

The two relay outputs are RT10 which is N.O. and RT11 which is N.C. These contacts are rated 60VA-1.25A-150VDC/200VAC MAX.

BELL ALARM RELAY FUNCTIONS

The relay outputs on this device can be used for wiring to remote indicators.

The Bell Alarm will latch the relay output when it receives a trip signal from the trip unit. Resetting the Bell Alarm is done by manually pushing the user-installed reset switch as shown in Figure 5, Page 3.

DISPLAY MODULE RELAY FUNCTIONS

The relay outputs on this device can be used for wiring to remote indicators.

The Display Module Relay works in conjunction with the Display Module (Cat. No. STDDM) mounted in the lower part of the trip unit. The front of this Display Module has a control switch to select alarm set points of 60, 70, 80, 90, or 100% of the continuous ampere rating of the circuit breaker. When the current level exceeds the switch setting a signal is sent to the Display Module Relay causing the contacts to close. The contacts remain closed only for the duration of the signal and do not latch closed.

GROUND FAULT SENSING AND RELAYING SYSTEM

When used with a Ground Fault Monitor Module (Cat. No. STDGFM), the Display Module Relay may be used as a Ground Fault Sensing and Relaying equipment system. For more information see the Ground Fault Sensing and Relaying Equipment instructions (Dwg. No. 121532).

NOTE: If the circuit breaker is powered up without the Module installed, the alarm will be set to its "ON" state.

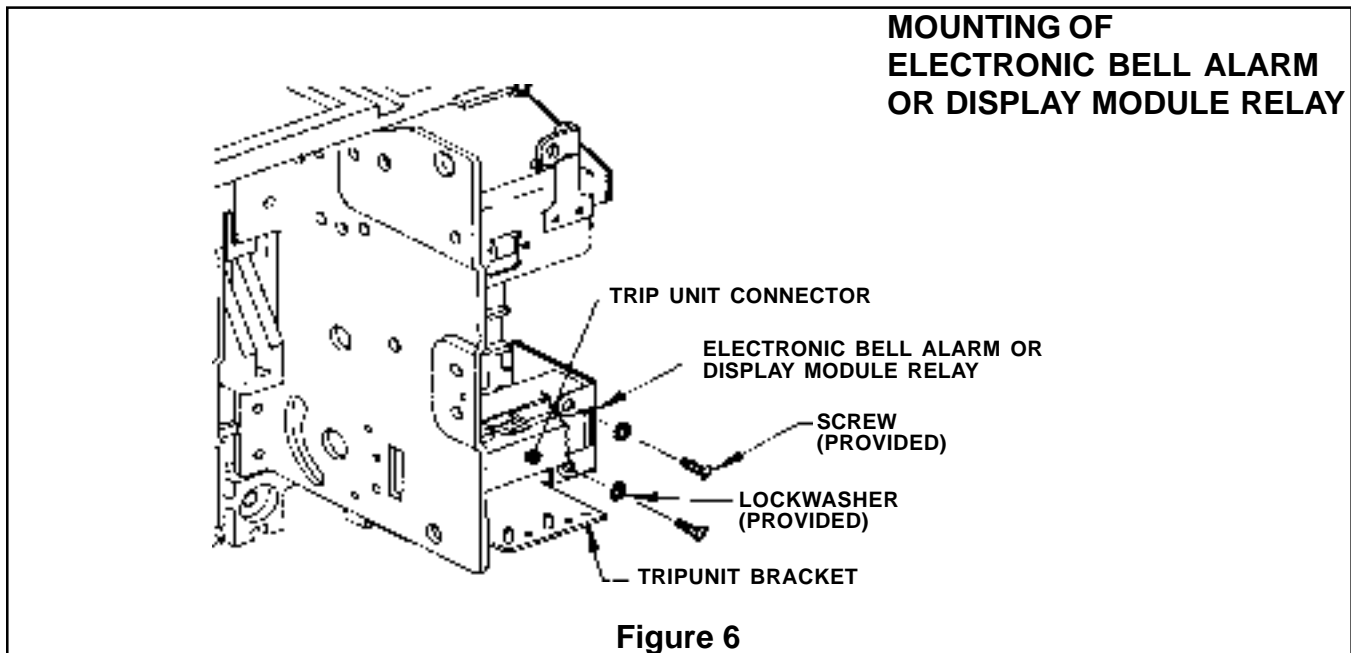

Installation Instructions



⚠ DANGER

**Hazardous voltage.
Will cause death or serious injury.**

Turn off and lock out all power supplying the device prior to cover(s) removal or while cover(s) are removed and when installing any internal or external accessory.

Replace the cover(s) and shield(s) before power supplying this device is turned on.



⚠ WARNING

**Mechanical Hazard.
Mechanism can cause severe injury when cover is removed.**

Before removing cover trip device by pushing "Push - To - Trip" button.



SAFETY INSTRUCTIONS

NOTE: These instructions outline the recommended installation procedure.

Table 1 - Trip Units		
STD20TLI	STD25TLI	STD32TLI
STD20TLS	STD25TLS	STD32TLS
STD20TLSI	STD25TLSI	STD32TLSI
STD20TLIG	STD25TLIG	STD32TLIG
STD20TLSG	STD25TLSG	STD32TLSG
STD20TLSIG	STD25TLSIG	STD32TLSIG

MOUNTING OF REMOTE INDICATOR PANEL

- Accessory installation should be completed before the breaker is mounted and connected. **If the breaker is installed turn off and lock out all power supplying the circuit breaker prior to cover removal or while cover is removed.** For ease of installation, it is highly recommended that the breaker be disconnected and removed from the panel or the enclosure.

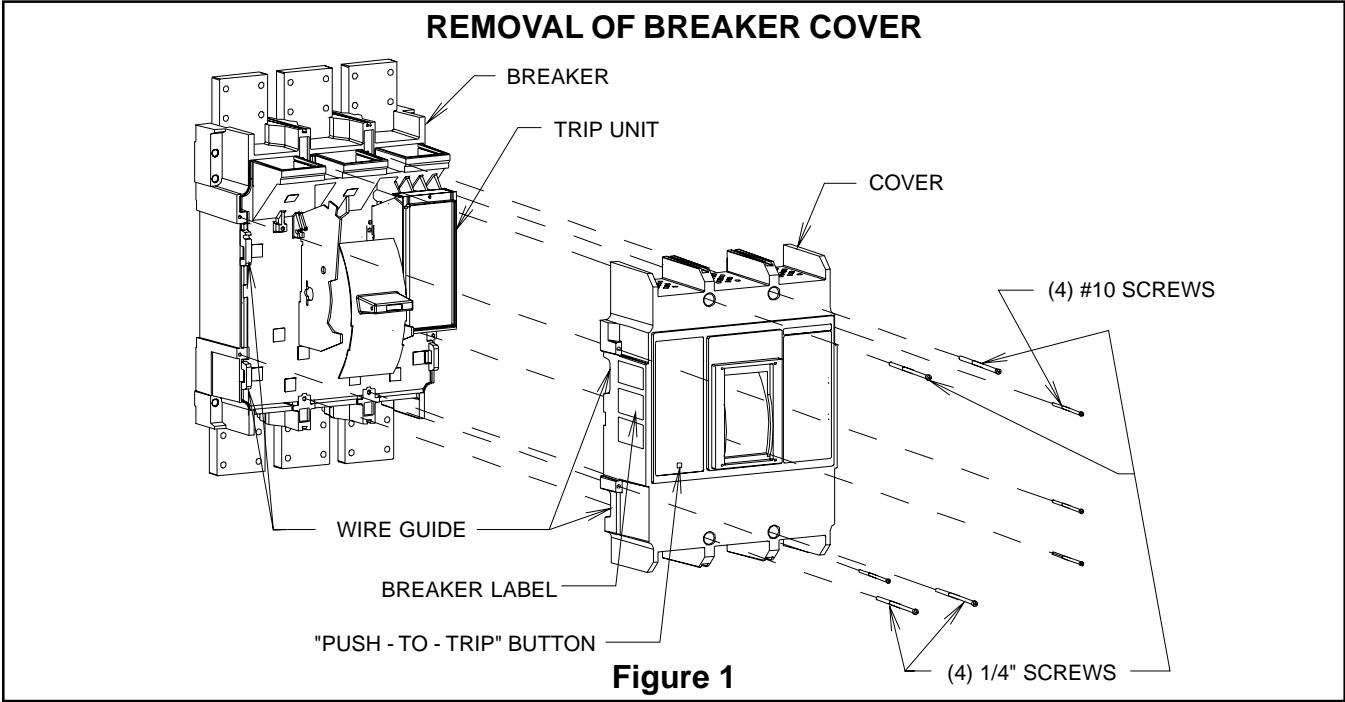



Installation Instructions

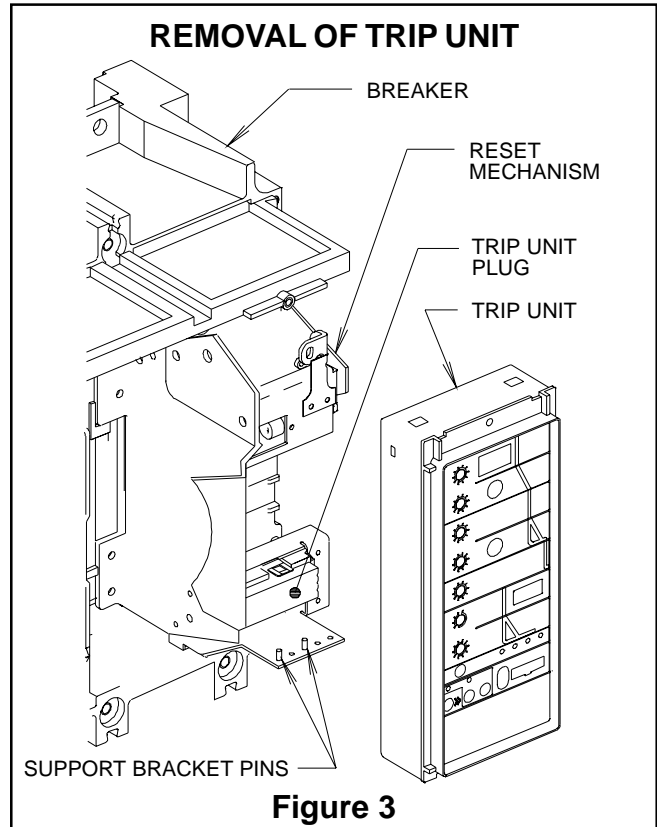
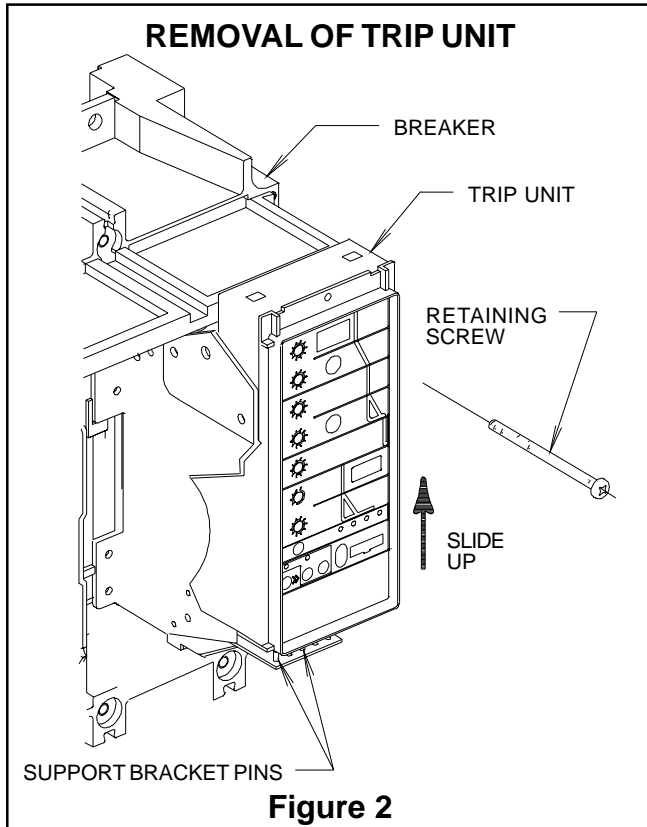

Breaker Wiring

1. The wires included in the plastic parts bag must be installed inside the breaker. These wires connect the trip unit to the terminal block mounted externally on the circuit breaker.
2. Trip breaker by pushing the "Push-to-Trip" button.
3. Remove the breaker cover by removing the (4) #10 Phillips head screws at the corners and the (4) 1/4" Phillips head screws in recesses of the cover (See Figure 1, Page 1).
4. Remove the trip unit retaining screw (See Figure 2).
5. Slide the trip unit up to clear the support bracket pins (See Figure 2).
6. Remove the trip unit by pulling it off the trip unit plug (See Figure 3).
7. With a small screwdriver press in the tab on the right side of the 36-pin trip unit plug and release it from the mounting bracket. Connect the wires provided between the trip unit 36-pin plug and the external terminal block. Refer to Figures 4 and 5, Page 3, for wire routing and connections. Snap the 36-pin plug back into the bracket, taking care to orient it properly.
8. Bundle wires using the wire ties provided and route them as shown in Figure 4, Page 3.
9. Replace the trip unit by pushing it onto the trip unit plug. Slide the trip unit over the support bracket pins. Secure the trip unit by replacing the mounting screw. Torque screw to 6-8 in-lbs (See Figures 2 and 3).
10. Replace the breaker cover. Check to ensure that wires exit the breaker through the wire guide and are not pinched by the breaker cover. Replace the 8 cover screws (See Figure 1, Page 1). Torque #10 (corner) screws to 28-32 in-lbs. Torque 1/4" screws to 68-75 in-lbs.

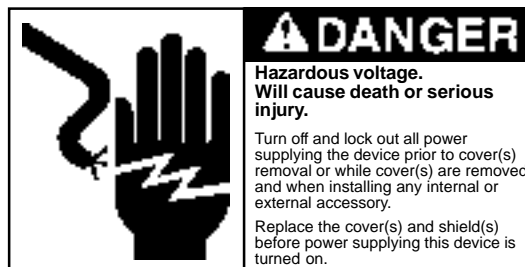

Installation Instructions

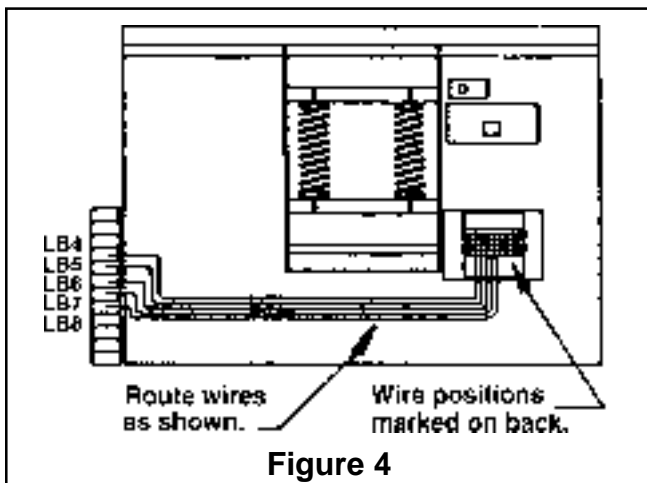

GENERAL

The Remote Indicator Panel can be either panel mounted or wall mounted. The intent is to allow mounting versatility yet keep all electrical connections within the switch-gear. NOTE: The maximum distance allowed between the breaker and Remote Indicator Panel is 10 feet.

Hardware List	Quantity
JUMPER WIRES	5
WIRE TIE	3

NOTE: ELECTRONIC BELL ALARM, DISPLAY MODULE RELAY, AND REMOTE INDICATOR PANEL ARE MUTUALLY EXCLUSIVE. NO COMBINATION OF THESE DEVICES IS PERMITTED.

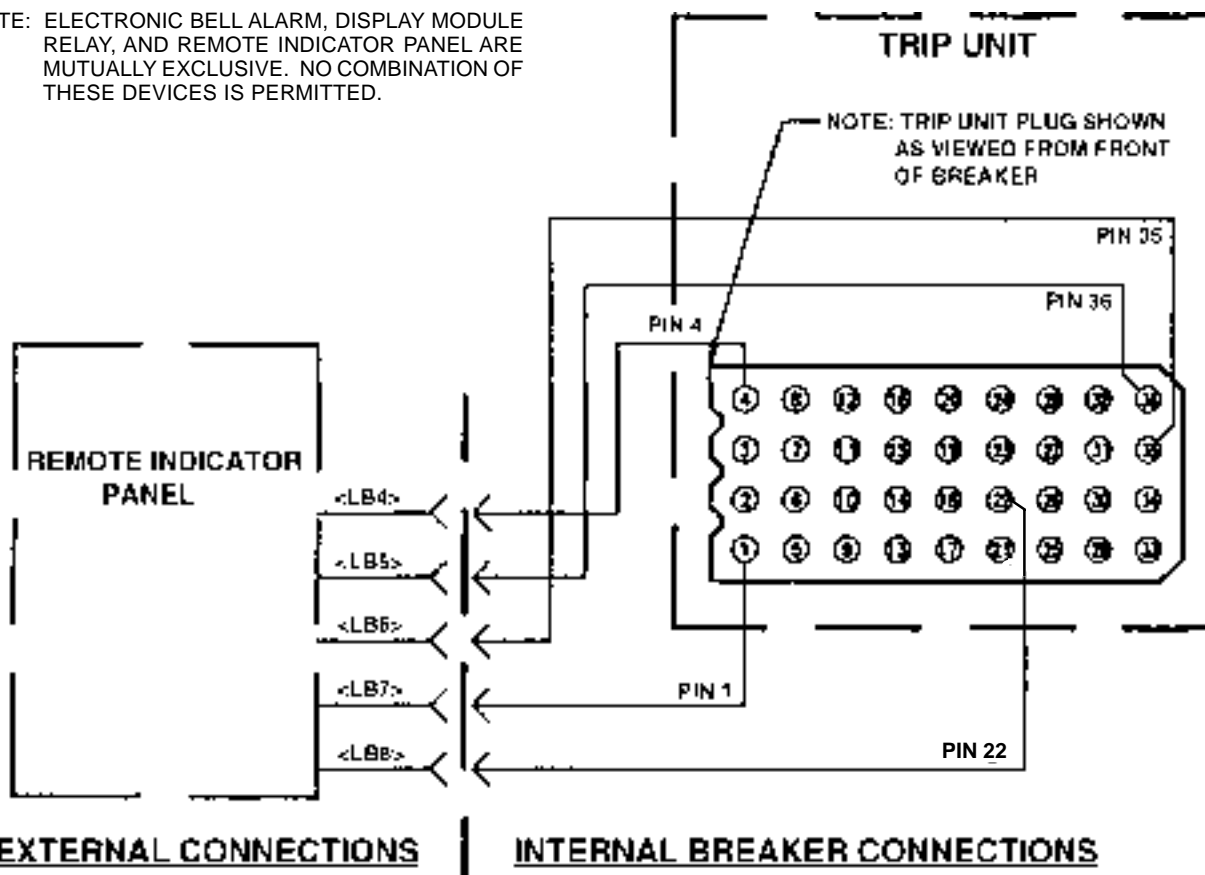

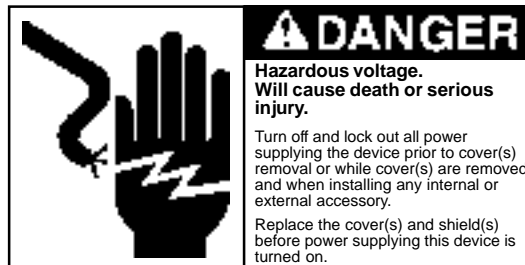

Installation Instructions

PANEL MOUNTING

Mounting hole must be cut in panel measuring 4-1/16" wide by 6-5/8" high. Remove both flange brackets and insert the Remote Indicator Panel through front of panel. Replace flange brackets positioned as shown in Figure 6, Page 5, and slide them up tight against back of panel. Tighten the four flange bracket screws securely.

WALL MOUNTING

This style mounting is intended for use inside switchgear housing. Reverse flange brackets as shown in Figure 7, Page 5. Place unit on flat surface, slide brackets down even with surface, and tighten screws. Hold unit in location desired. Mark and drill all 4 holes for a #6 screw. Mount Remote Indicator Panel with (4) #6 screws (not supplied).

WIRING

Note that the Remote Indicator Panel terminal blocks are removable for ease of wiring. Pull them straight out to unplug, insert wires, tighten screws, then plug them back into the circuit board.

Wire Remote Indicator Panel to circuit breaker using terminals on left side marked LB4-LB8. Connect them to the corresponding terminal block positions located on the left bottom side of the breaker. These wires must be 18 AWG minimum with a maximum length of 10 feet.

The 5 relay outputs located on the bottom right terminal block of the Remote Indicator Panel (See Figure 8, Page 6) may be wired to your system using 18 AWG wire. The contact ratings of these relays are 60VA-1.25A-150VDC/200VAC MAX.

Connect supply power to the top right terminal block of the Remote Indicator Panel as marked (See Figure 8, Page 6). Use the correct voltage as marked on the nameplate. Make sure the housing is grounded using the #8-32 screw provided.

RELAY FUNCTIONS

The relay outputs on this device can be used for wiring to remote indicators.

In a trip condition only one of the four relays marked G.F. (Ground Fault), S.T. (Short Time), O.L. (Over Load), or S.C. (Short Circuit) will latch and stay latched until the Reset button on the front of the Remote Indicator Panel is pushed. Which relay latches is dependent on the trip condition of the breaker.

The other relay marked M.A. (Module Alarm) does not latch, but pulls in and drops out dependent on the switch setting of the Module located in the trip unit. This could be either a Display Module or a Ground Fault Monitor Module. When the current exceeds the switch setting, relay "M.A." pulls in and when the current goes below the switch setting, it drops out. If a Display Module or a Ground Fault Monitor Module is not used in conjunction with the Remote Indicator Panel, the relay "M.A." pulls in when the breaker is energized.

GROUND FAULT SENSING AND RELAYING SYSTEM

When used with a Ground Fault Monitor Module (Cat. No. STDGFM) the Remote Indicator Panel may be used as a Ground Fault Sensing and Relaying equipment system. For more information see the Ground Fault Sensing and Relaying Equipment instructions (Dwg. No. 121532).

NOTE: If the circuit breaker is powered up without the Module installed, the alarm will be set to its "ON" state.



⚠ DANGER
 Hazardous voltage.
 Will cause death or serious injury.
 Turn off and lock out all power supplying the device prior to cover(s) removal or while cover(s) are removed and when installing any internal or external accessory.
 Replace the cover(s) and shield(s) before power supplying this device is turned on.

Installation Instructions

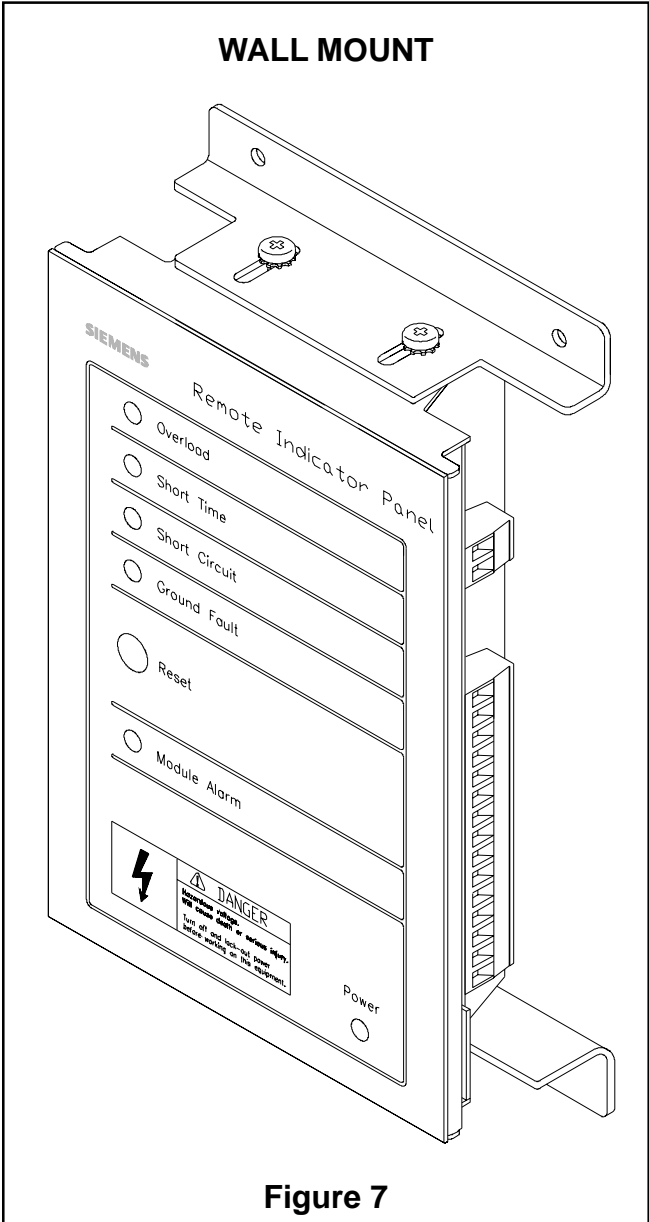
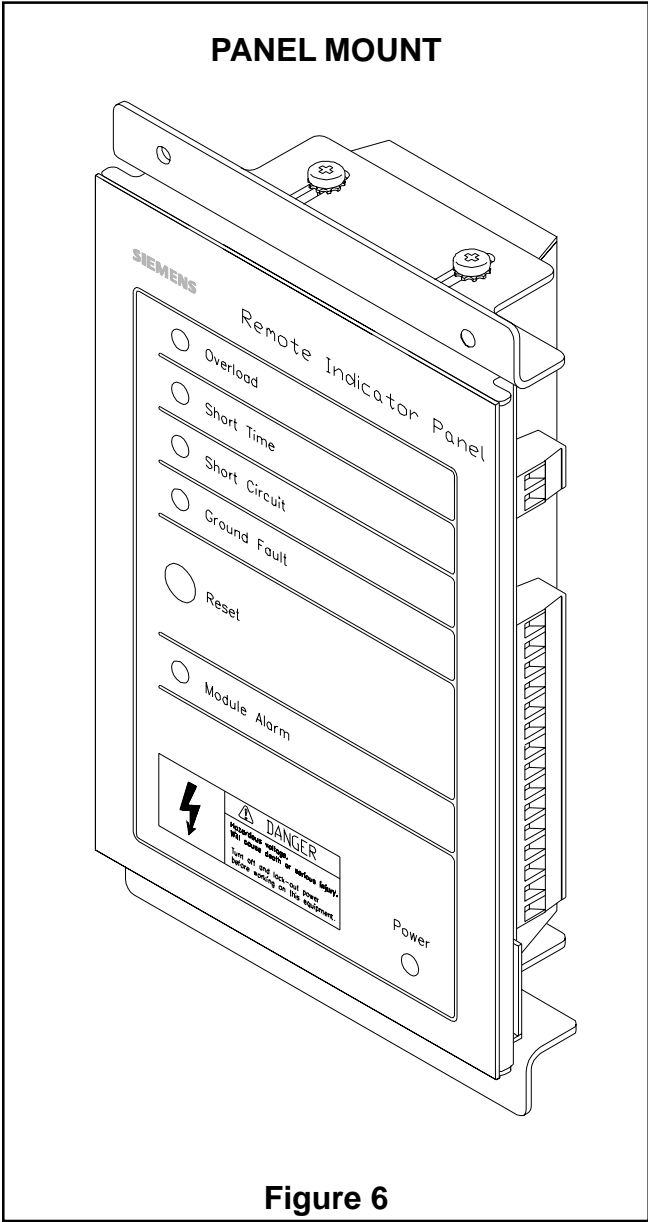

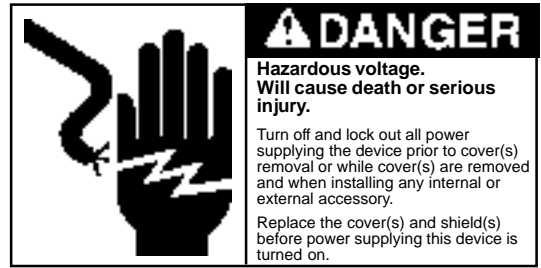

Installation Instructions

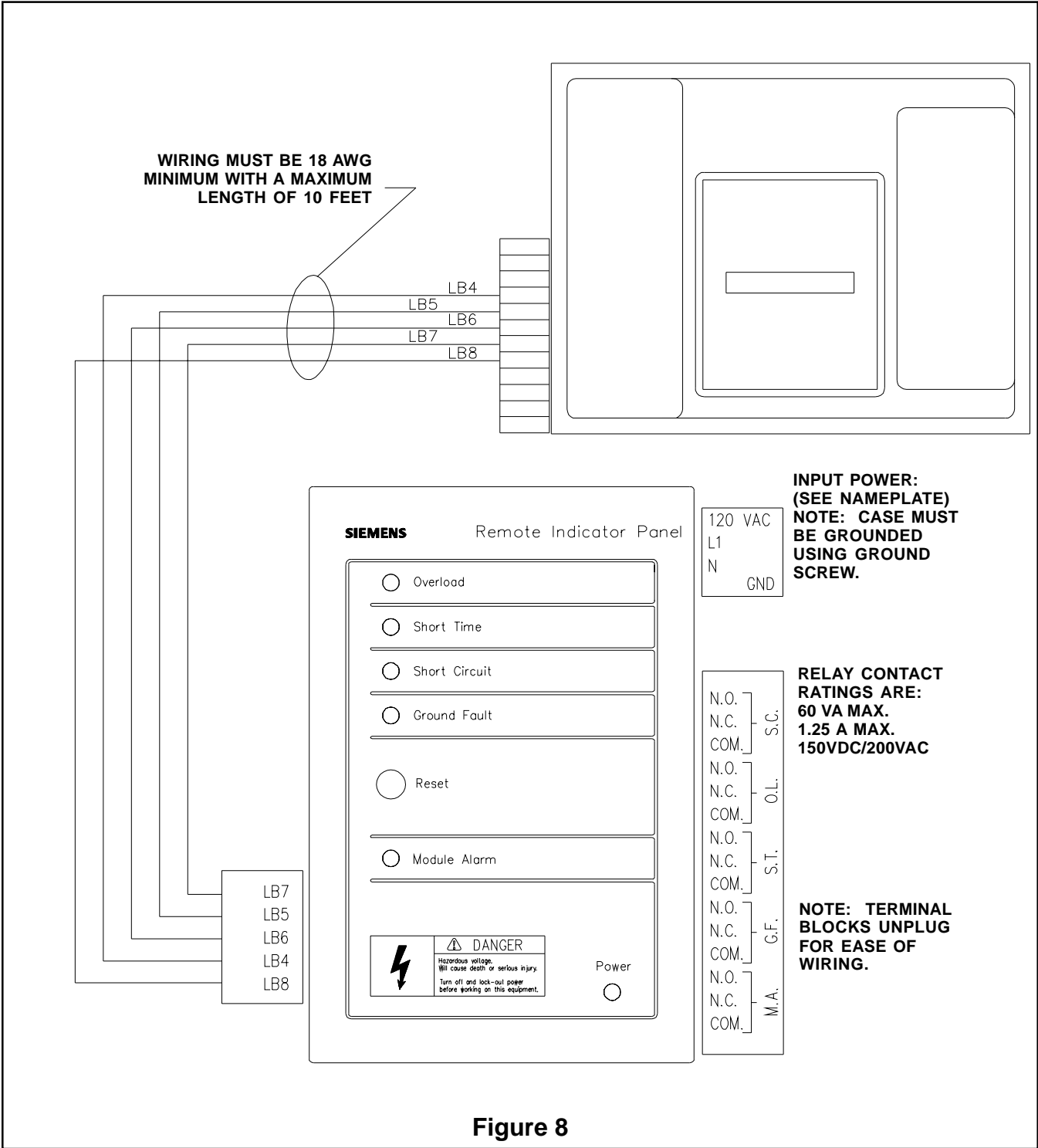

Siemens Energy & Automation, Inc.
 Bellefontaine, OH 43311 U.S.A.
 © 1997 Siemens Energy & Automation, Inc.

Installation Instructions



⚠ DANGER

Hazardous voltage.
Will cause death or serious injury.

Turn off and lock out all power supplying the circuit breaker prior to cover(s) removal or while cover(s) are removed and when installing any internal or external accessory.

Replace the cover(s) and shield(s) before power supplying this device is turned on.



SAFETY INSTRUCTIONS

NOTE: These instructions outline the recommended installation procedure.

Terminals have been tested per UL 486B with standard stranded cable.

MOUNTING OF PRESSURE WIRE CONNECTOR

1. Accessory installation should be completed before the breaker is mounted and connected. **If the breaker is installed turn off and lock out all power supplying the circuit breaker when installing any internal or external accessory.** For ease of installation, it is highly recommended that the breaker be disconnected and removed from the panel or the enclosure.
2. Attach power cables (A) to pressure wire connector (C) and torque cable set screws (B) to 375 in-lbs.
3. Mount pressure wire connectors (C) to the breaker terminals (D) with mounting bolts, Belleville washnuts, and Belleville washers provided. Pressure wire connector must be mounted in the holes closest to the breaker case (See Figure 1). Torque mounting bolts to 375 in-lbs.

Catalog Number	Wire Range	Torque	
		Set Screw	Mounting Bolt
TA6R600STD	(1-6) 250-600 kcmil CU7AL	375 in-lbs.	375 in-lbs.

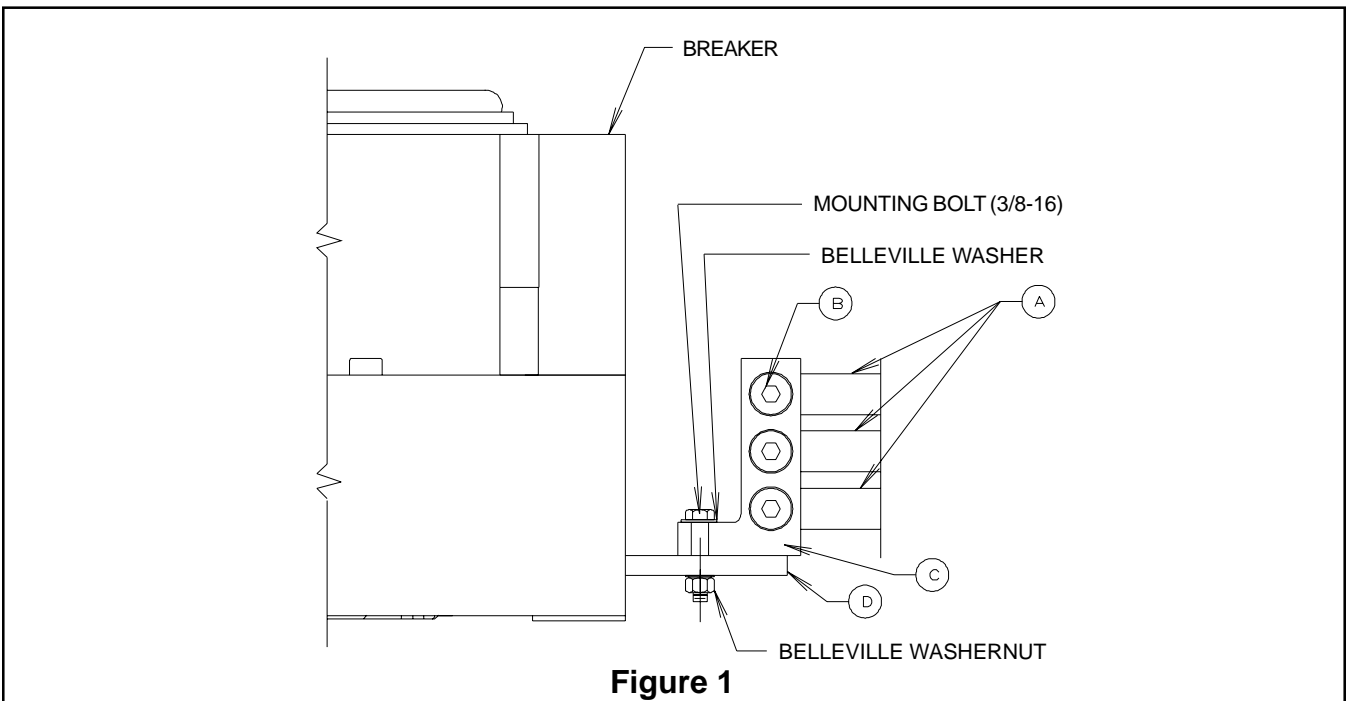

Installation Instructions



⚠ DANGER

**Hazardous voltage.
Will cause death or serious injury.**

Turn off and lock out all power supplying the device when installing any internal or external accessory.



SAFETY INSTRUCTIONS

Table 1 - Trip Units		
STD20TLI	STD25TLI	STD32TLI
STD20TLS	STD25TLS	STD32TLS
STD20TLSI	STD25TLSI	STD32TLSI
STD20TLIG	STD25TLIG	STD32TLIG
STD20TLSG	STD25TLSG	STD32TLSG
STD20TLSIG	STD25TLSIG	STD32TLSIG

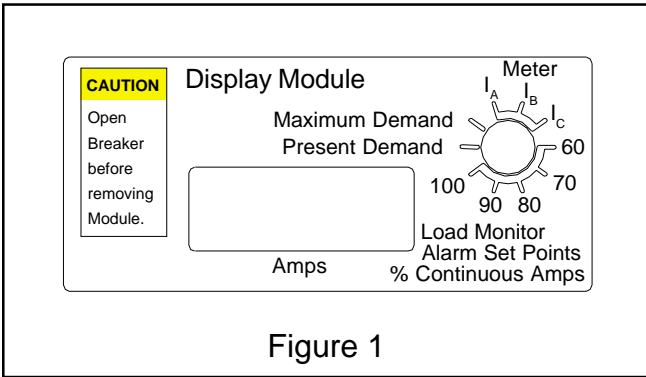

Display Module

The Display Module provides features for allowing the user to locally monitor the phase currents. The switch to set and select the display is accessible to the user through a hole in the clear cover of the trip unit. If the breaker sees an overload at any time the display will flash "-OL-" until the breaker trips or the overload is removed.

Load Current Meter

This feature provides a local display of the present 3-phase currents. The user may display the current value by setting the switch to the I_A , I_B , or I_C positions.

Load Monitor Alarm Set Points

This feature provides a local alarm display and an output signal for external alarm when the average of the phase currents exceeds the alarm set point. The display automatically resets itself when the alarm condition ceases. The alarm output level is a 5-volt DC level. The signal may be used to display an alarm and to provide a set of relay contacts using a Remote Indicator Panel (Cat. No. STDRIP120) or an internal Display Module Relay (Cat. No. STDDMR24, STDDMR48, STDDMR120, or STDDMR125). The alarm set point may be 60, 70, 80, 90, or 100 percent of the continuous current setting.

Also, note that if the circuit breaker is powered up without the Display Module installed, the alarm will be set to its "ON" state.

Present Demand

This feature provides a display of the present current demands. The present current demands are calculated averages over fifteen (15) minute intervals. The user may display the most recently stored value at any time by setting the switch to the present demand position.

Maximum Demand

This feature provides a display of the maximum current demand since the breaker was last reset. The maximum demand is reset by depressing both the phase and ground fault test pushbuttons simultaneously. The phase and ground fault pushbuttons are located on the STD Electronic Trip Unit in the integral testing section.



Installation Instructions

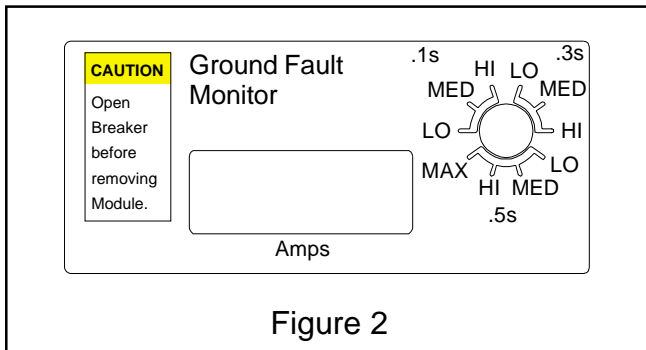

Figure 2

Ground Fault Monitor

The Ground Fault Monitor (GFM) is an optional module that allows the user to locally monitor the ground fault current and can be used in trip units with or without the integral ground fault protection function. Trip units with the integral ground fault protection function are identified by a "G" in the catalog number and the presence of ground fault adjustments on the face of the trip unit. If the trip unit is equipped with ground fault protection, the Ground Fault Monitor utilizes the same ground fault sensing method as the electronic trip unit. If the trip unit is not equipped with ground fault protection, the GFM uses a *residual* ground fault sensing method. The Ground Fault Monitor works *independently* of the trip unit's ground fault protection.

Settings

There are three ground fault pickup levels offered on the Ground Fault Monitor:

- "LO" equals 20 percent of the frame rating.
- "MED" equals the average of the "LO" and "HI" pickup levels.
- "HI" equals either the frame rating or 1200 amps, *whichever is less*.

The ground fault delays are divided into three fixed time delay bands: 0.1, 0.3, and 0.5 seconds. The "MAX" setting is defined as a 1200 amp pickup and 0.5 second delay.

Display

The Ground Fault Monitor displays the ground fault current in amps. When the ground fault current reaches a level 12 percent below the selected pickup setting, the amps display will start to flash. When the ground fault current exceeds the selected pickup setting, the display will flash "-OL-" for overload and the alarm line will be set to its "ON" state.

Remote Interface

The Ground Fault Monitor can be utilized with a Display Module Relay (mounted inside the breaker) or a Remote Indicator Panel (externally mounted) to provide a set of relay contacts for ground fault alarm. When used in conjunction with either of these devices and a Shunt Trip, the Ground Fault Monitor can be used as Ground Fault Sensing and Relaying equipment per U. L. 1053. For more information see the Installation Instructions for the Ground Fault Sensing and Relaying System (Dwg. No. 121532).

Also, note that if the circuit breaker is powered up without the Ground Fault Monitor installed, the alarm will be set to its "ON" state.



Installation Instructions

Installation:

NOTE: These instructions outline the recommended installation procedure.

To install this device:

1. Trip breaker by pushing the "Push-to-Trip" button.
2. Remove the two sealable cover screws from the face of the trip unit.
3. Remove the clear plastic trip unit cover using a screwdriver in the notches provided at the top and bottom of the trip unit.
4. Remove the blank module cover at the bottom of the trip unit. The cover snaps out.
5. Install the Ground Fault Monitor Module by pressing both sides down into the opening until the snap fits click, locking it in place.
6. Replace the clear cover. Make sure that the Ground Fault Monitor Module switch is accessible through the hole on the bottom right side of the clear cover.
7. Install the two cover screws and seal the trip unit.

For additional information, refer to Siemens Publication No. IPIM-0283A, STD Frame Breaker Information and Instruction Guide.

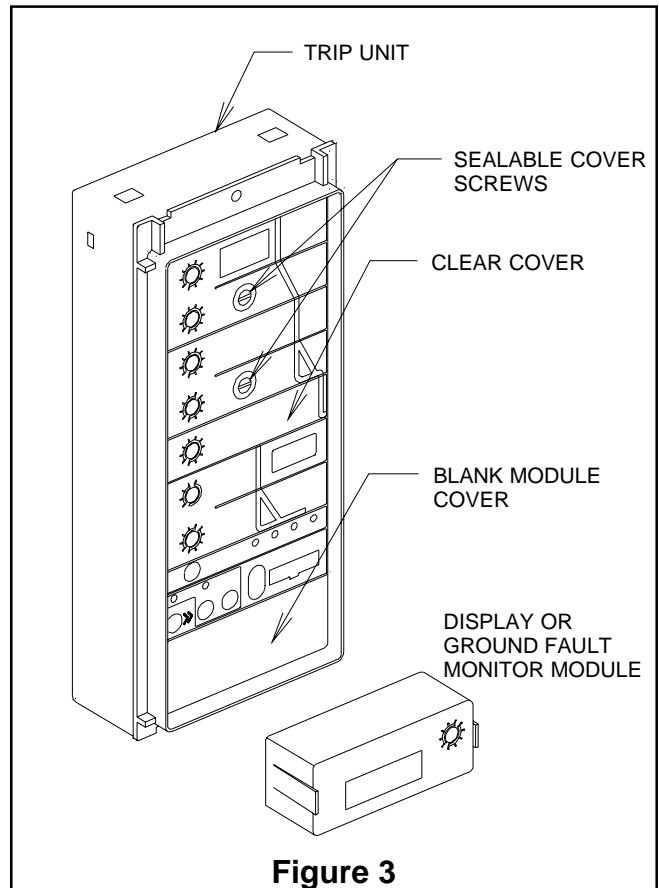

Figure 3

Siemens Energy & Automation, Inc.
Bellefontaine, OH 43311 U.S.A.

Installation Instructions

⚠ DANGER

Hazardous voltage.
Will cause death or serious injury.

Turn off and lock out all power supplying the device prior to cover(s) removal or while cover(s) are removed and when installing any internal or external accessory.

Replace the cover(s) and shield(s) before power supplying this device is turned on.

SAFETY INSTRUCTIONS

GROUND FAULT SENSING AND RELAYING:

This system will provide Class I ground fault protection as described in UL STANDARD 1053, GROUND FAULT SENSING AND RELAYING EQUIPMENT.

System Components:

UL Listed Circuit Breaker Components and Accessory Components

- | | |
|--|----------------------|
| 1. Circuit Breakers | Table 2 |
| 2. Trip Units | Table 1 |
| 3. Rating Plugs | Table 3 |
| 4. GF Monitor Module | STDGFM |
| 5. Display Module Relay
or Remote Indicator Panel | Table 4
STDRIP120 |
| 6. Shunt Trip Device | Table 5 |

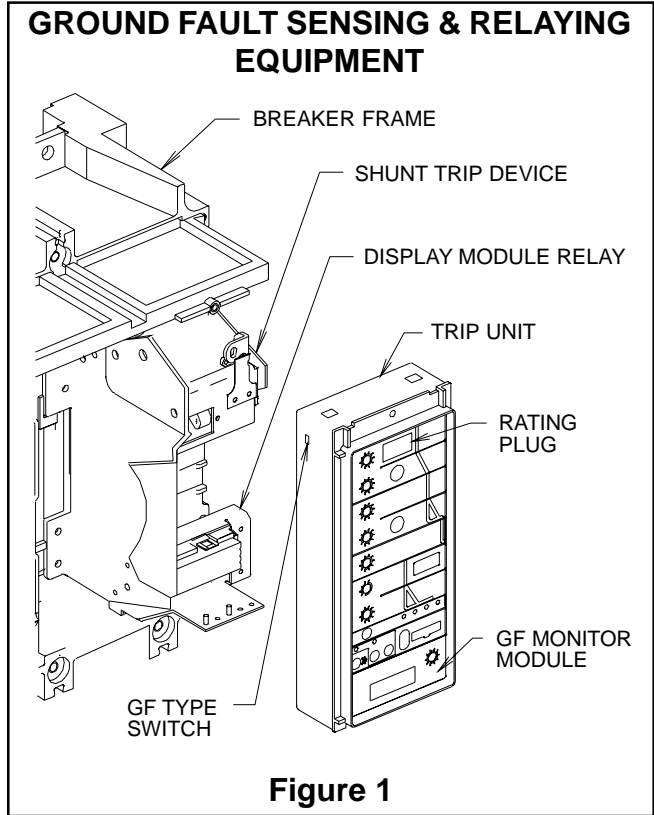

STD20TLI	STD25TLI	STD32TLI
STD20TLS	STD25TLS	STD32TLS
STD20TL SI	STD25TL SI	STD32TL SI
STD20TL IG	STD25TL IG	STD32TL IG
STD20TL SG	STD25TL SG	STD32TL SG
STD20TL SIG	STD25TL SIG	STD32TL SIG

20STD1000	25STD1600	32STD1600
20STD1200	25STD2000	32STD2000
20STD1600	25STD2500	32STD2500
20STD2000		32STD3000
		32STD3200

STD62000	SHTD62000	SHHTD62000
STD62500	SHTD62500	SHHTD62500
STD63200	SHTD63200	SHHTD63200

STDDMR24
STDDMR48
STDDMR120
STDDMR125

STDST12	STDST120
STDST24	STDST240
STDST48	STDST480
STDST125	



Installation Instructions

System Description:

This Ground Fault Sensing & Relaying Equipment system is based on the Type STD molded case circuit breaker. The breaker must be equipped with an electronic Trip Unit and Rating Plug. The trip unit can be the type with or without the built-in ground fault tripping function. The breaker must also have a GF Monitor Module, a Shunt Trip Device, and either a Display Module Relay or Remote Indicator Panel. For a system completely enclosed within the breaker case, the internally mounted Display Module Relay is used. If remote cause of trip information is required, the Remote Indicator Panel may be used in place of the Display Module Relay.

System Operation:

The user must first set the desired ground fault pickup and delay settings on the Ground Fault Monitor Module. These settings are independent from the trip unit built-in ground fault setting (if available). When a ground fault above the selected pickup occurs, the breaker will delay based on the module settings and when the proper time has elapsed, issue a signal to the internal Display Module Relay or external Remote Indicator Panel. The output contacts of the relay can then be used to trigger the Shunt Trip Device, thus tripping the circuit breaker.

Testing:

General Instructions:

1. The interconnected system shall be evaluated by qualified personnel when initially installed. It is also recommended that this be done periodically thereafter.
2. The proper location of the sensors around the bus of the circuit to be protected shall be determined. This can be done visually with knowledge of which bus is involved.
3. The grounding points of the system shall be verified to determine that ground paths do not exist that would bypass the sensors.
4. The polarity of the sensor connections must agree with the installation instructions to avoid improper operation.
5. A simulated test is to be done using a low voltage, high current source. This test is not intended to verify calibration of the ground fault protection, but to verify that it is functioning properly.

6. The results of this testing should be recorded on the form provided at the end of this document or other appropriate forms and should be available to the inspection authority.
7. These breakers may be set for different modes of operation, Residual or Ground Return, as described in the instructions supplied with the circuit breaker. For further information on applications, refer to the NEMA standards publication No. PB 2.2 Application Guide for Ground Fault Protective Devices for Equipment.¹

Test Operation

GF Type Switch set to RESIDUAL

Outgoing Circuit Method (if trip unit does not provide ground fault protection, this is the method used)

3 Phase / 3 Wire

Using Figure 2, Page 4, and Illustration 1 or 2, individually test breaker poles A, B, and C for proper Ground Fault operation.

Each of the circuit breaker's front panel controls should be set to the highest setting. Set the Ground Fault Monitor to the LO pickup on the .1 second delay band. Using a low voltage current source, apply a test current equal to 50% of the rating plug value. The circuit breaker must trip.

3 Phase / 4 Wire

Using Figure 3, Page 4, and Illustration 1 or 2, individually test breaker poles A, B, and C in conjunction with the proper neutral sensor for proper Ground Fault operation.

Each of the circuit breaker's front panel controls should be set to the highest setting. Set the Ground Fault Monitor to the LO pickup on the .1 second delay band. Using a low voltage current source, apply a test current equal to 50% of the rating plug value. The circuit breaker must not trip. Reduce the test current to zero.

Using a suitable means, short the X1 wire and the X2 wire connections together on the Neutral Sensor. Reapply a test current equal to 50% of the rating plug value. The circuit breaker must trip. Reduce the test current to zero and remove the shorting means from the Neutral Sensor.



Installation Instructions

GF Type Switch set to GROUND RETURN Ground Return Method

3 Phase / 3 Wire or 3 Phase / 4 Wire

Using Figure 4, Page 4, and Illustration 1 or 2, test neutral sensor for proper Ground Fault operation. Each of the circuit breaker's front panel controls should be set to the highest setting. Set the Ground Fault Monitor to the LO pickup on the .1 second delay band. Using a low voltage current source, apply a test current equal to 50% of the rating plug value. The circuit breaker must trip.

For more information:

See Siemens Publication No. IPIM-0283A, STD Frame Breaker Information and Instruction Guide, for ground fault sensing schemes and wiring schematics.

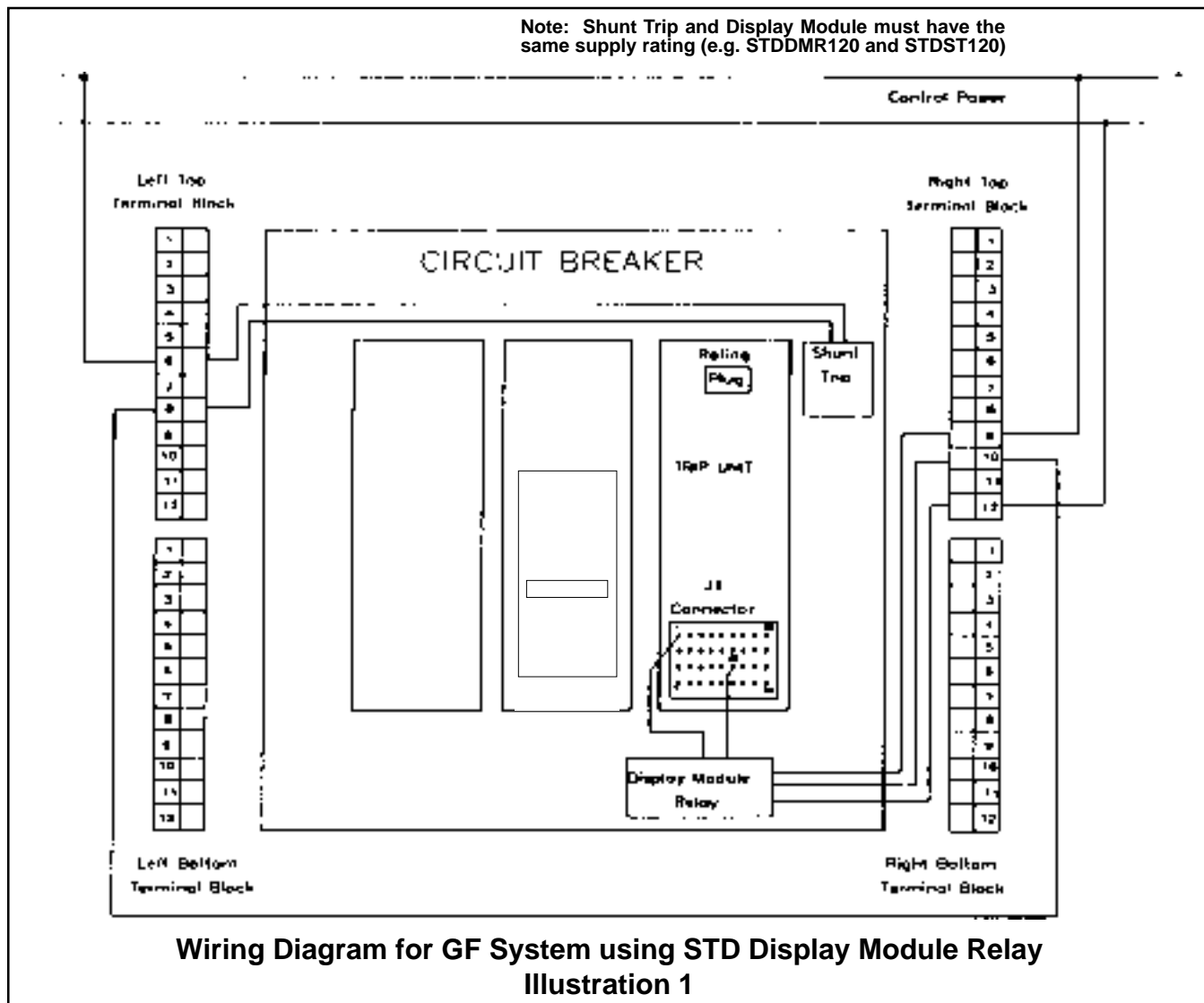



Installation Instructions

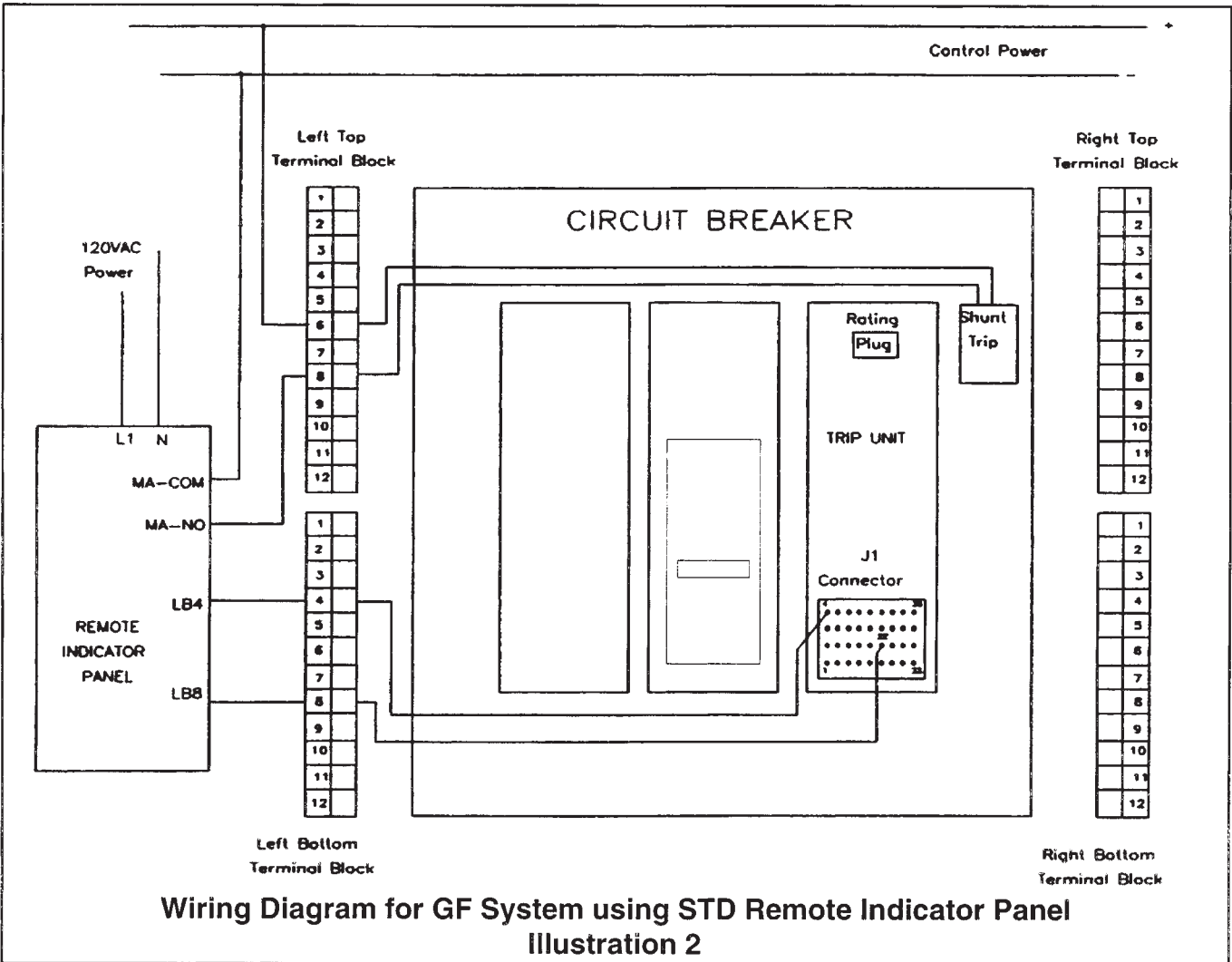
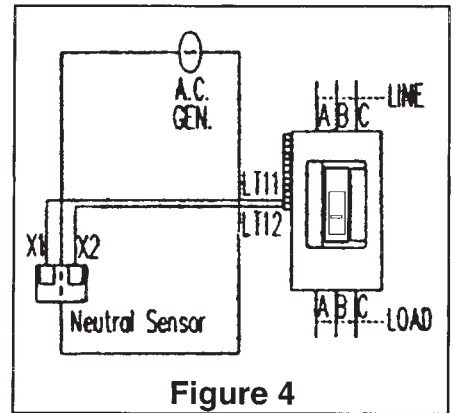
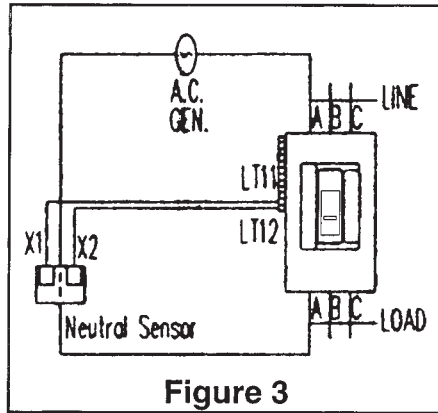
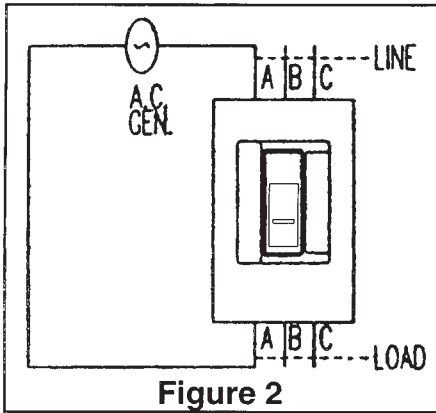



Installation Instructions

GROUND FAULT TEST RECORD

Date Tested: _____ Tested By: _____
Breaker Cat. No. _____ Location _____
Rating Plug Value _____
Results _____
A _____
B _____
C _____

GROUND FAULT TEST RECORD

Date Tested: _____ Tested By: _____
Breaker Cat. No. _____ Location _____
Rating Plug Value _____
Results _____
A _____
B _____
C _____

¹NEMA PB 2.2 is available from: National Electrical Manufacturers Association
2101 L. Street, N.W., Suite 300
Washington, D.C. 20037

Siemens Energy & Automation, Inc.
Bellefontaine, OH 43311 U.S.A.

Item: Fixed Mounted Breaker Mechanical Interlock Assembly

For Use With: Siemens' Circuit Breakers or Molded Case Switches

Type: STD62000, STD62500, STD63200, SHTD62000,
SHTD62500, SHTD63200, SHHTD62000, SHHTD62500,
SHHTD63200, TD62000, TD62500, and TD63200

Cat. No.: STDMIF32, STDMIF32L12

Page 1 of 2

Installation Instructions

	⚠ DANGER
	Hazardous voltage. Will cause death or serious injury. Turn off and lock out all power supplying the circuit breaker prior to cover(s) removal or while cover(s) are removed and when installing any internal or external accessory. Replace the cover(s) and shield(s) before power supplying this device is turned on.



SAFETY INSTRUCTIONS

NOTE: These instructions outline the recommended installation procedure.

INSTALLATION OF FIXED MOUNTED BREAKER MECHANICAL INTERLOCK ASSEMBLY

NOTE: The Mechanical Interlock Assembly must be installed after the breaker has been installed in the switchboard.

1. To install the first interlock cable assembly remove the two bottom 3/8 nuts from the bolts on the top of the breaker "A" mounting assembly.
2. Secure the cable assembly by aligning its two holes with the holes in the mounting brackets of breaker "A." Reinstall the two nuts (See Figure 1).



Figure 1

3. The white plastic cable cap should fit flush against the rear of the breaker (See Figure 2). If the cable does not fit flush against the breaker, adjustments can be made with the cable jam nuts (see Figure 2).

NOTE: This assembly is preadjusted and should need little or no adjustment.

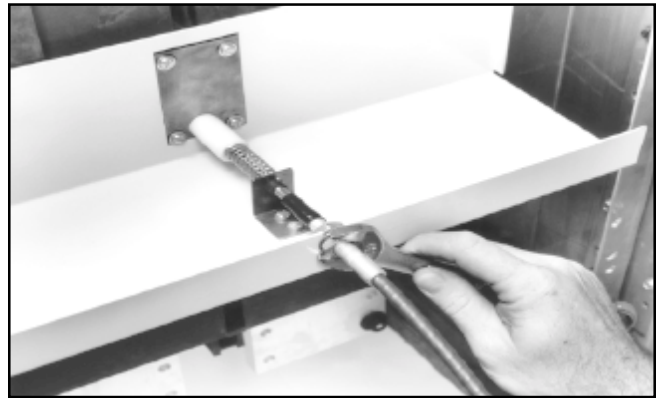

Figure 3

4. Remove the wire guard from the left side of breaker "B" (See Figure 3). Place the loose end of the cable from breaker "A" on the left side of the breaker "B" interlock assembly.

NOTE: Route the cable away from all bus bars and make sure the cable has a minimum bend radius of five inches. Secure the cable as needed.



Figure 3

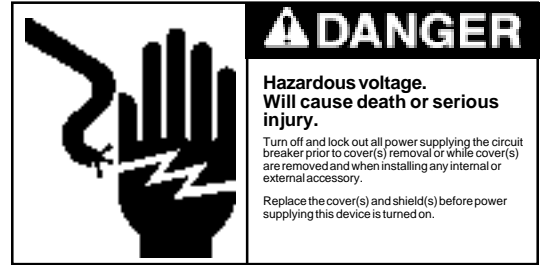

Installation Instructions

- Secure the cable end by inserting the cable rod into the trip bracket (See Figure 4).

NOTE: Make sure one #10-32 nut is located on the bottom of the threaded rod.



Figure 4

- Tighten the cable jam nuts onto the support bracket (See Figure 5). The washer may go on either side of bracket.



Figure 5

- With the trip bracket in the down position, turn the bottom #10-32 nut snug against the trip bracket.
- To secure the rod end to the trip bracket, put the plain washer, lock washer, and the #10-32 nut on the rod end and tighten both #10-32 nuts.
- Check the cable by closing breaker "A." The cable should move the trip bracket of breaker "B" in an upward direction.



Cable installed on Interlock Housing

- Reinstall the wire guard that was removed in step four.
- Repeat steps one through ten for the second inter-lock cable assembly for breaker "B."
- With both cable assemblies installed, test breakers "A" and "B" to insure that only one breaker can be closed at the same time. If the system does not work properly do not use breakers and consult the factory.

MAXIMUM BREAKER CENTER TO CENTER DISTANCE

STDMIF32		STDMIF32L12	
HORIZONTAL	VERTICAL	HORIZONTAL	VERTICAL
38"	36"	110"	108"

Installation Instructions

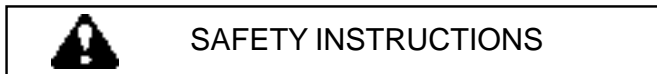
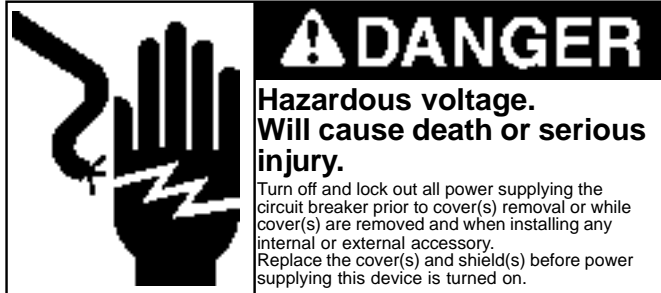

NOTE: These instructions outline the recommended installation procedure.

INSTALLATION OF FIXED MOUNTED BREAKER KEY OPERATOR

1. Accessory installation should be completed before the breaker is mounted and connected. **If the breaker is installed, turn off and lock out all power supplying the circuit breaker before installing any internal or external accessories.** For ease of installation, it is highly recommended that the breaker be disconnected and removed from the panel or the enclosure.
2. Rotate the key on the lock so the plunger is in the withdrawn position.
3. Place the lock against the mounting bracket (See Figure 1).
4. Secure the lock with two 1/4-20 bolts, plain washers, lock washers, and 1/4-20 hex nuts. Tighten bolts to 5-7 ft-lbs.
5. Operate the lock assembly several times. The trip lever must move freely with the lock plunger. The breaker will be in the tripped position when the plunger is extended.



Figure 1

6. Rotate the key so the plunger is in the withdrawn position. Close the breaker. Rotate the key to extend the plunger and verify that the breaker opens. With the plunger extended and the key removed, verify that the breaker remains in the open position. If the key interlock does not function properly do not use this breaker and consult the factory.

NOTE: Locks must be ordered separately. Order Kirk lock type F or Superior lock type B-4003. Both locks must be ordered with 3/8 inch bolt projection. Key removed when bolt is extended.

Installation Instructions



⚠ DANGER
Hazardous voltage.
Will cause death or serious injury.

Turn off and lock out all power supplying the circuit breaker prior to cover(s) removal or while cover(s) are removed and when installing any internal or external accessory.

Replace the cover(s) and shield(s) before power supplying this device is turned on.

⚠ SAFETY INSTRUCTIONS

NOTE: These instructions outline the recommended installation procedure.

MOUNTING OF PADLOCK DEVICE ASSEMBLY

1. Accessory installation should be completed before the breaker is mounted and connected. **If the breaker is installed turn off and lock out all power supplying the circuit breaker when installing any internal or external accessory.** For ease of installation, it is highly recommended that the breaker be disconnected and removed from the panel or the enclosure.
2. Prior to installation, if padlock device will be used to lock circuit breaker in the ON position, remove Tab "A" (See Figure 2, Page 2) by grasping tab with pliers and using an up and down motion to break tab free. Remove sharp edges with file.
3. Installation of this accessory does not require removal of the breaker cover.

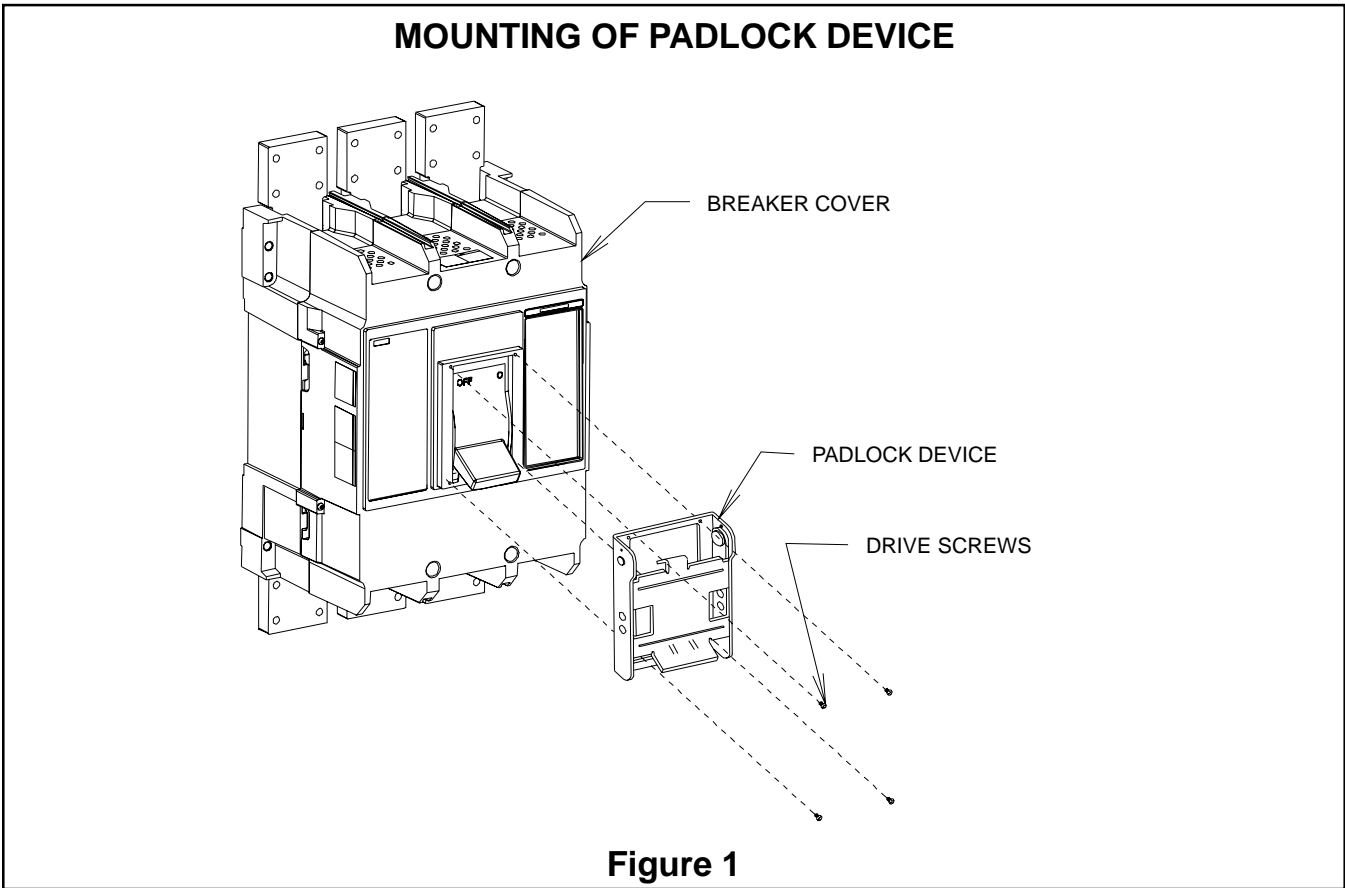
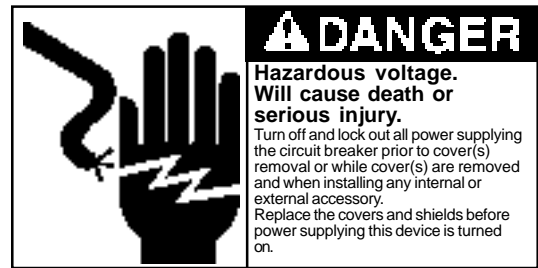

Figure 1



Installation Instructions

4. With breaker in the OFF position, assemble padlock device to breaker by positioning over handle as shown (See Figure 1, Page 1). Align mounting holes in padlock device with holes in breaker escutcheon and insert drive screws. Using a hammer, firmly tap drive screws into holes until padlock device is secured to breaker.
2. To padlock breaker in ON position:
Note: Requires removal of Tab "A" (See Step 2, Page 1).
 - a. Move breaker handle to ON position.
 - b. Rotate moveable part of padlock device over handle until .375 inch diameter holes are aligned.
 - c. Install padlock hasp through .375 inch diameter holes.

OPERATION OF PADLOCK DEVICE ASSEMBLY

1. To padlock breaker in OFF position:
 - a. Move breaker handle to OFF position.
 - b. Rotate moveable part of padlock device toward handle until .375 inch diameter holes are aligned.
 - c. Install padlock hasp through .375 inch diameter holes.

IMPORTANT: USE PADLOCK WITH 1/4 INCH MINIMUM DIAMETER HASP.

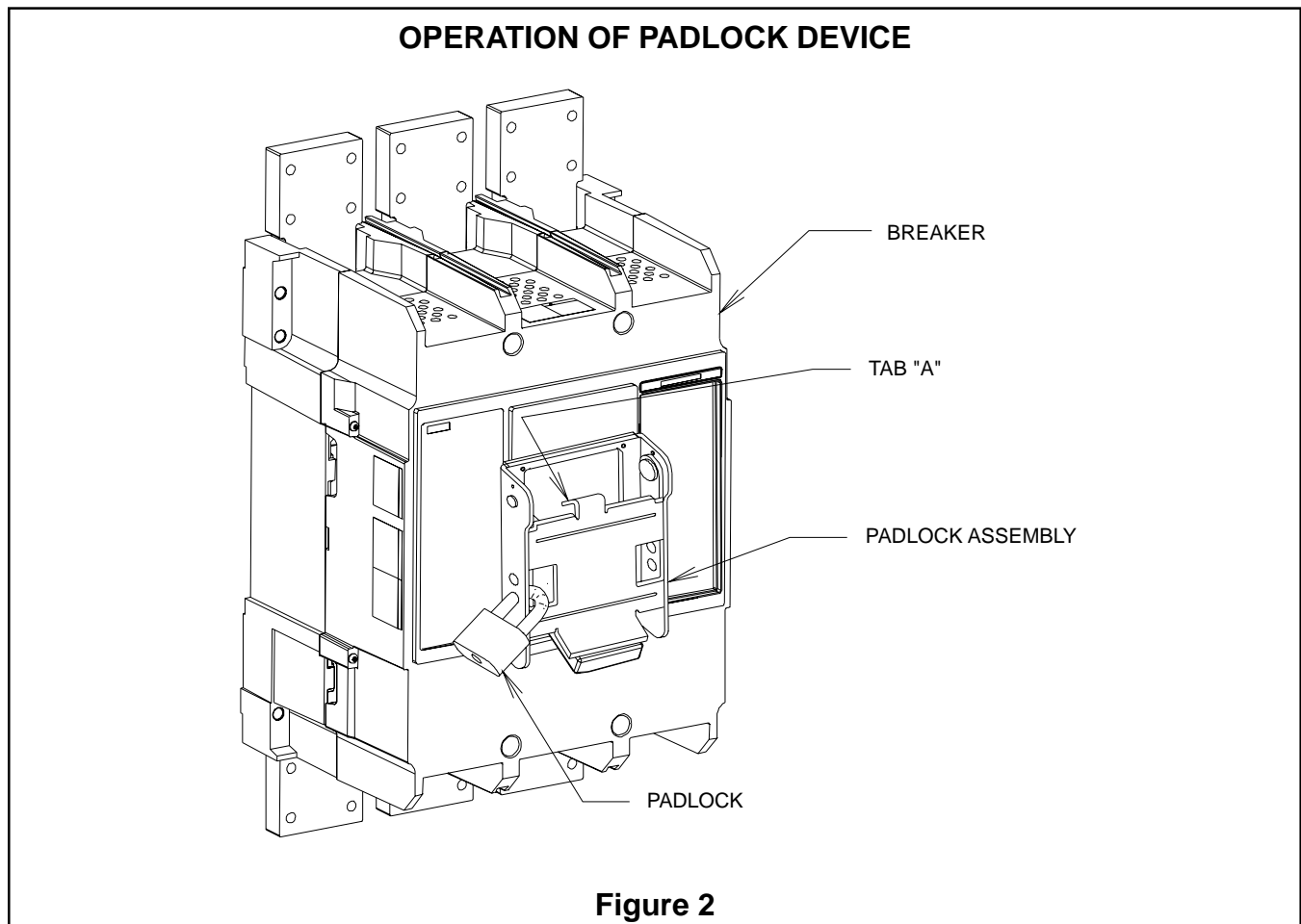

Installation Instructions



⚠ DANGER

Hazardous voltage.
Will cause death or serious injury.

Turn off and lock out all power supplying the device prior to cover(s) removal or while cover(s) are removed and when installing any internal or external accessory.

Replace the cover(s) and shield(s) before power supplying this device is turned on.

⚠ SAFETY INSTRUCTIONS

NOTE: These instructions outline the recommended installation procedure.

MOUNTING OF TERMINAL BLOCK MOUNT

1. Accessory installation should be completed before the breaker is mounted and connected. **If the breaker is installed turn off and lock out all power supplying the circuit breaker when installing any internal or external accessory.** For ease of installation, it is highly recommended that the breaker be disconnected and removed from the panel or the enclosure.
2. Installation of this accessory does not require removal of the breaker cover.
3. Remove the 4 #10 Phillips head screws on the left and right sides of the breaker cover (do not remove screws in recesses of the cover). Place the terminal block mount over the screw holes. Re-install the screws.
4. Secure the assembly by tightening the cover screws. Torque screws to 28 to 32 in-lbs.

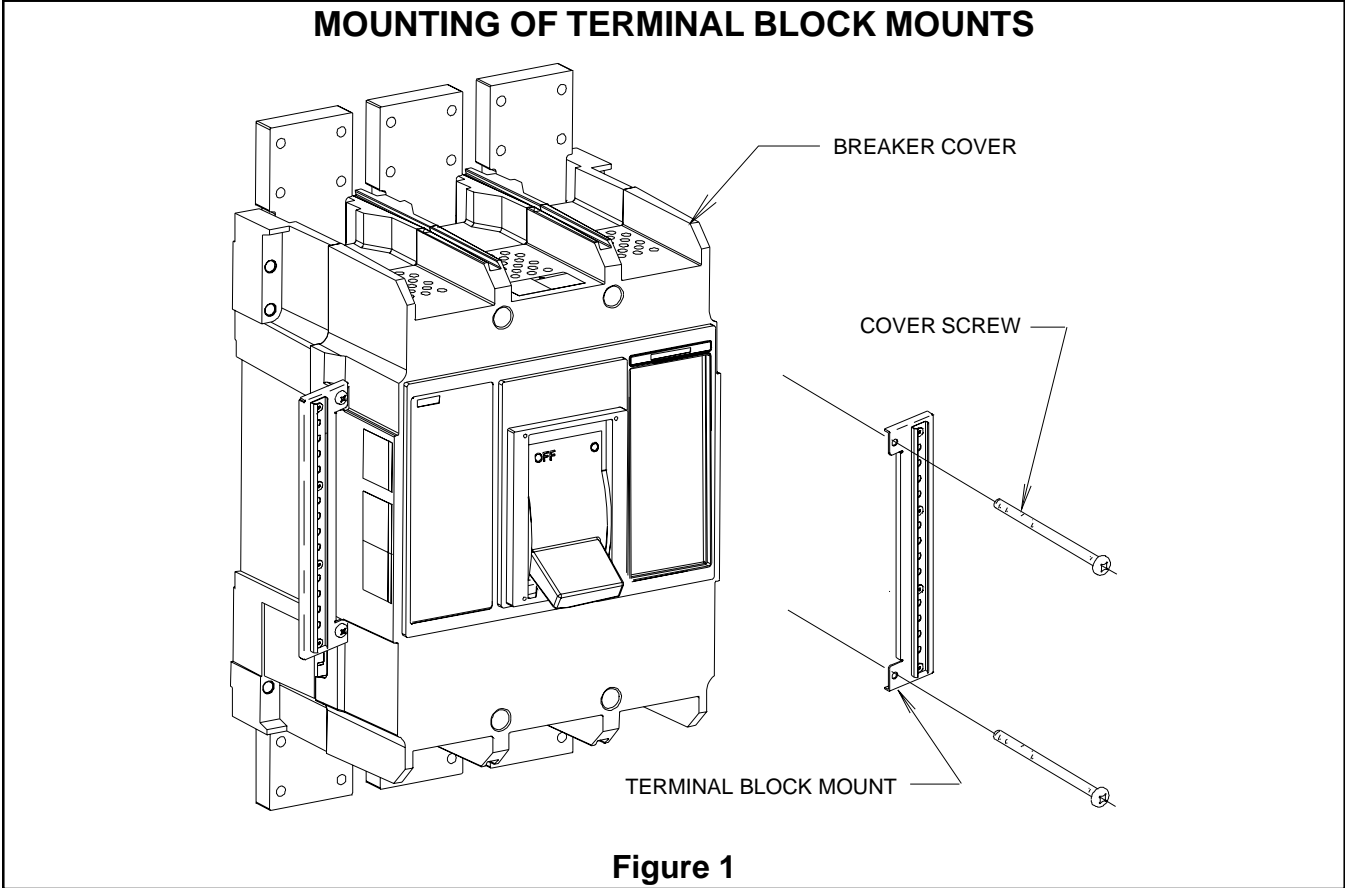



⚠ DANGER

Hazardous voltage.
 Will cause death or serious injury.

Turn off and lock out all power supplying the device prior to cover(s) removal or while cover(s) are removed and when installing any internal or external accessory.

Replace the cover(s) and shield(s) before power supplying this device is turned on.

Installation Instructions

MOUNTING OF TERMINAL BLOCK ASSEMBLY

1. The terminal block mounts should be installed before installing the terminal block assemblies. If the terminal block mounts are not installed see the terminal block mount instructions on page 1.

2. After the terminal block mounts are installed, insert the terminal block assembly (See Figure 2).

Note: Each terminal block assembly contains four terminal blocks and one label.

3. To ensure proper positioning of the terminal block assemblies see Figure 3.

4. Insert label into the groove of the terminal block (See Figure 2).

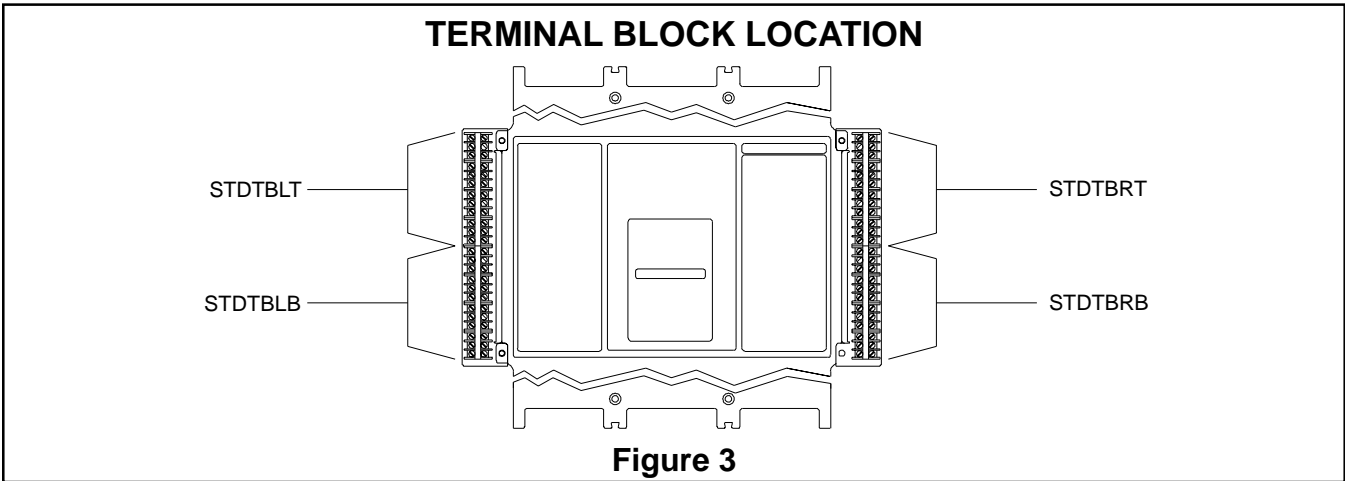
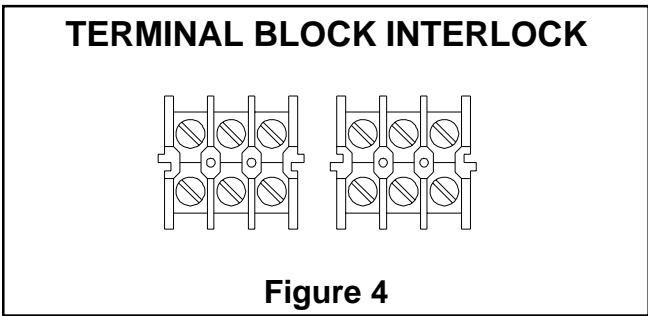
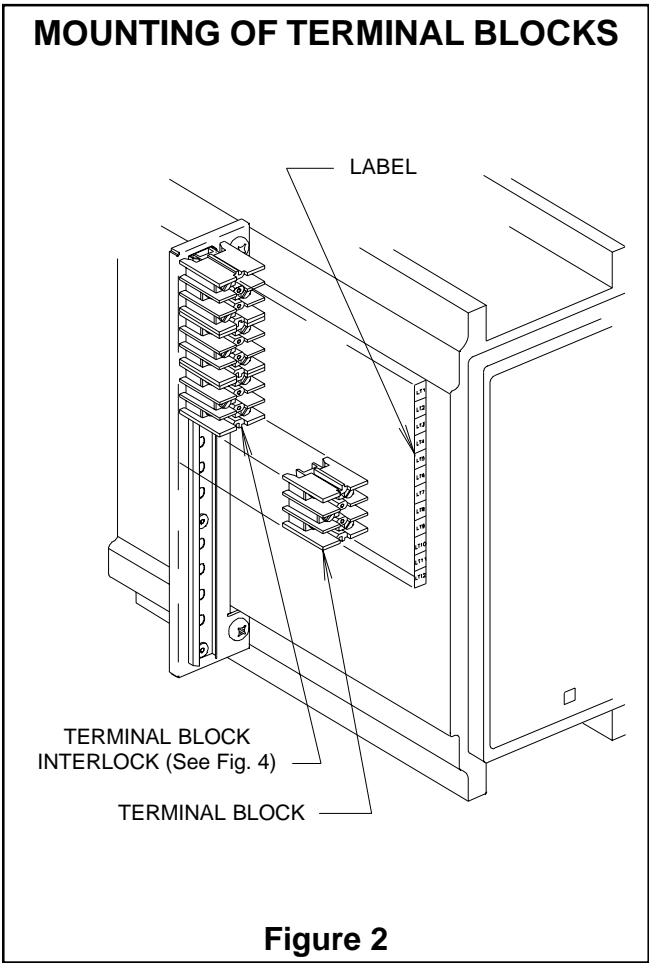

External Accessories

Control Terminal Blocks

Contact blocks are required for secondary control wiring. The appropriate number and location of contact blocks should be selected from the table below based on the features and accessories ordered on each circuit breaker.

Contact Block Position	Accessory							Auxiliary Switches	
	Alarm Switch	Shunt Trip	Under-voltage Release	Neutral Sensor	Remote Indication Panel	Zone Interlock and ACCESS	Bell Alarm or Display Module Relay	1A and 1B	4A and 4B
								2A and 2B	5A and 5B
3A and 3B	6A and 6B								
LT	X	X	X	X					
LB					X	X			
RT							X		X
RB								X	X

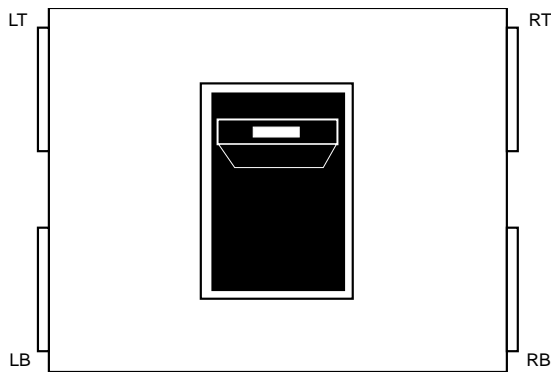

Figure 4. Secondary Contact Block Locations

Control Terminal Blocks

Contact Position	Catalog Number
LT	STDTBLT
LB	STDTBLB
RT	STDTBRT
RB	STDTBRB

Mounting Bracket for Terminal Block

For mounting Control Terminal Blocks to fixed mounted breakers. One bracket required for mounting locations LT and LB and a separate bracket required for mounting locations RT and RB.

Catalog Number
STDTBM

Installation Instructions



⚠ DANGER
Hazardous voltage.
Will cause death or serious injury.

Turn off and lock out all power supplying the circuit breaker prior to cover(s) removal or while cover(s) are removed and when installing any internal or external accessory.

Replace the cover(s) and shield(s) before power supplying this device is turned on.

⚠ SAFETY INSTRUCTIONS

NOTE: These instructions outline the recommended installation procedure.

MOUNTING OF TERMINAL CONNECTOR

1. Accessory installation should be completed before the breaker is mounted and connected. **If the breaker is installed turn off and lock out all power supplying the circuit breaker when installing any internal or external accessory.** For ease of installation, it is highly recommended that the breaker be disconnected and removed from the panel or the enclosure.
2. Mount terminal connector (A) to the breaker terminal (B) with mounting bolts, nuts, and washers provided (See Figure 1).
3. Torque bolts to 240 in-lbs.
4. This terminal connector is not suitable for horizontal mounting.

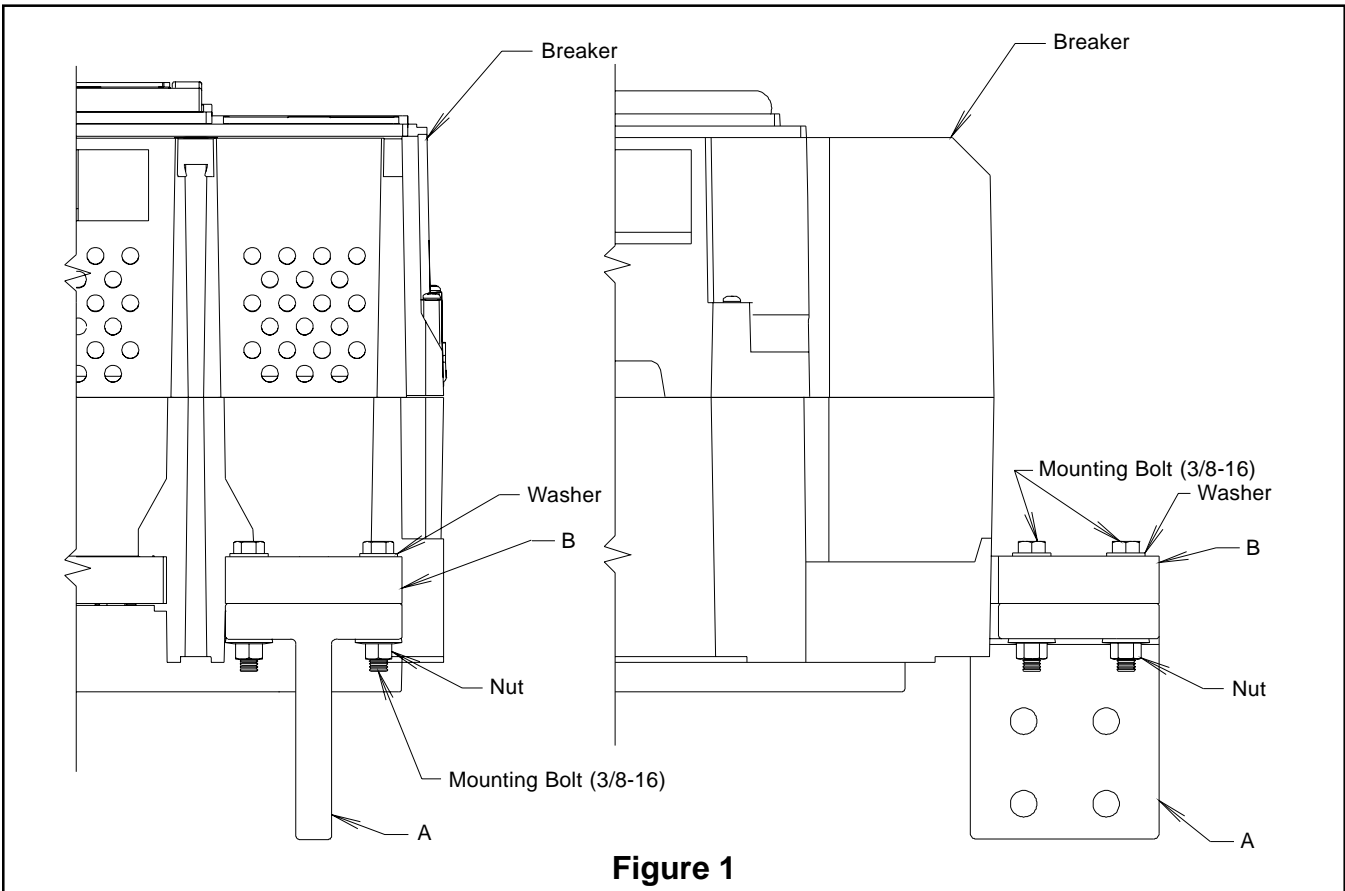

Installation Instructions



⚠ DANGER

Hazardous voltage. Will cause death or serious injury.

Turn off and lock out all power supplying the device prior to cover(s) removal or while cover(s) are removed and when installing any internal or external accessory.

Replace the cover(s) and shield(s) before power supplying this device is turned on.



⚠ WARNING

Mechanical Hazard. Mechanism can cause severe injury when cover is removed.

Before removing cover trip device by pushing "Push - To - Trip" button.



SAFETY INSTRUCTIONS

NOTE: These instructions outline the recommended installation procedure.

Tools Required: 1/4" flat blade screwdriver, 1/4" screw starter (magnetic or clip), #2 phillips screwdriver, #3 phillips screwdriver.

1. Accessory installation should be completed before the breaker is mounted and connected. **If the breaker is installed turn off and lock out all power supplying the circuit breaker prior to cover removal or while cover is removed.** For ease of installation, it is highly recommended that the breaker be disconnected and removed from the panel or the enclosure.
2. Trip breaker by pushing the "Push-to-Trip" button.

Use transformers with the following breaker frame ratings only.

Transformer Cat No.	Transformer Ampere Rating	Breaker Frame
N20STD	2000	STD2000
N25STD	2500	STD2500
N32STD	3200	STD3200

⚠ CAUTION

Incorrect neutral sensor transformer could cause nuisance tripping or improper operation of the ground fault function.

Use only the above series of neutral sensors.

The ampere rating of the neutral sensor must match the maximum frame rating of the circuit breaker.

Introduction:

N20STD

This neutral sensing transformer is designed to be mounted on a bus bar with maximum dimensions of 3.00" by .75".

N25STD, N32STD

These neutral sensing transformers are designed to be mounted on a bus bar with maximum dimensions of 5.00" by 1.25".

Mounting:

N20STD

Position the neutral sensor as close as possible to the associated circuit breaker and fabricate two .312" diameter holes in the bus 1.75" apart, as shown in Figure 5, Page 4. Mount the neutral sensor to the bus as shown with 1/4-20 hardware (not provided). Torque mounting bolts to 50 in-lbs maximum.

N25STD, N32STD

Position the neutral sensor as close as possible to the associated circuit breaker and fabricate four .312" diameter holes in the bus 1.50" by 4.00" apart, as shown in Figure 6, Page 4. Orient L-mounting brackets as necessary for the mounting configuration being used and secure to the neutral sensor with the hardware provided. Mount the neutral sensor to bus or panel with 1/4-20 hardware (not provided). Torque mounting bolts to 50 in-lbs maximum.



Installation Instructions

Important:

The STD series of electronic trip circuit breakers equipped with ground fault protection may be used in the Residual or Ground Return modes. When used in the Residual mode the orientation of the neutral sensing transformer is important for proper operation. See Figures 7 and 8, Page 5, for proper orientation of the neutral sensor for Residual mode Ground Fault. Special orientation of the neutral sensor is not required when used in the Ground Return mode of Ground Fault. See Figure 9, Page 5, for installation of the neutral sensor for Ground Return mode.

Installation Procedure

1. Check if wires marked LT11 and LT12 are routed out of circuit breaker at top left corner. If they are, proceed to step 7. If not, these wires must be installed. Contact the factory for Ground Fault Wiring Kit Part No. 121795. Follow steps 2 through 6 to install these wires.
2. Remove the breaker cover by removing the (4) #10 Phillips head screws at the corners and the (4) 1/4" Phillips head screws in recesses of the cover (See Figure 1).
3. Remove the trip unit retaining screw (See Figure 3, Page 3).
4. Slide the trip unit up to clear the support bracket pins (See Figure 3, Page 3).
5. Remove the trip unit by pulling it off the trip unit plug (See Figure 4, Page 3).
6. With a small screwdriver press in the tab on the right side of the 36 pin trip unit plug and release it from the mounting bracket. Connect the wire provided marked LT11 from trip unit plug position #8 to terminal block position LT11. Connect wire marked LT12 from trip unit plug position #15 to terminal block position LT12. Make sure these connectors are fully seated and locked into the trip unit plug. Snap the 36 pin connector back into the mounting bracket taking care for proper orientation. Route wires as shown in Figure 10, Page 5.
7. Replace trip unit plug, trip unit, and cover taking care not to pinch any wires. Torque Trip Unit mounting screws to 12-14 in. lbs. Torque 1/4" main cover screws to 68-75 in.lbs. Torque #10 Corner Cover screws to 28-32 in. lbs.

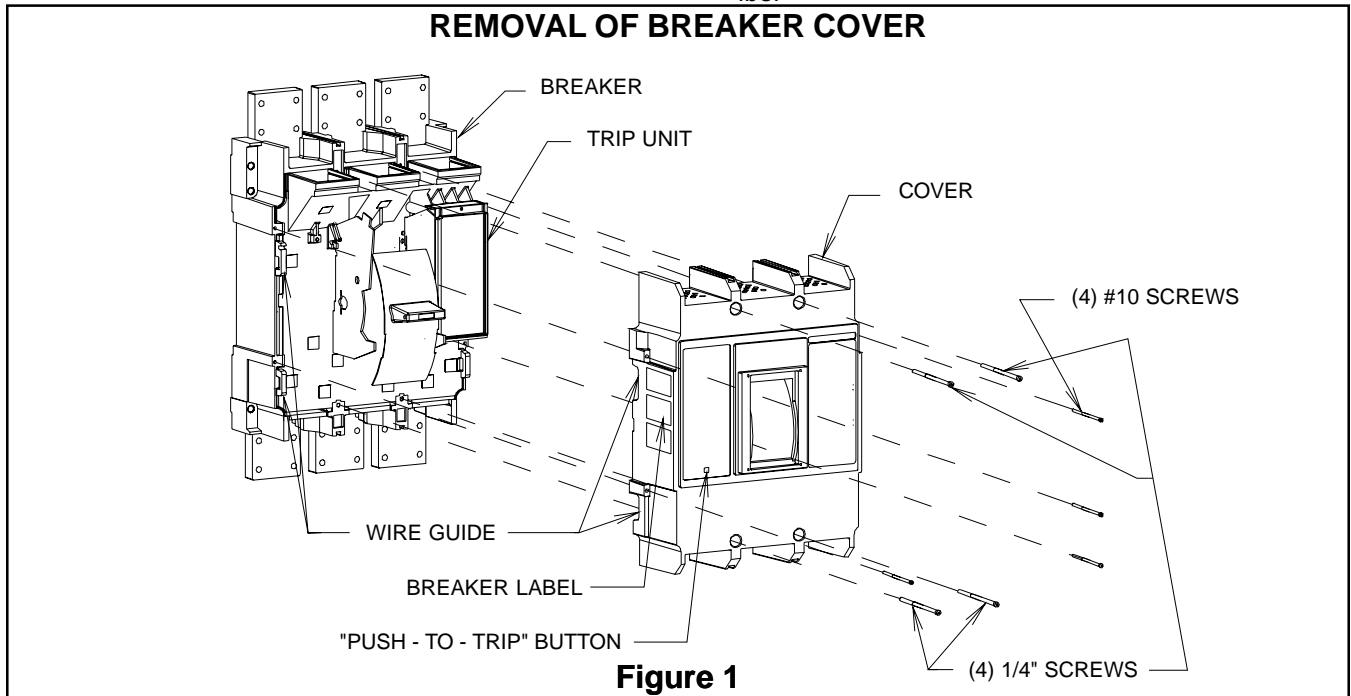

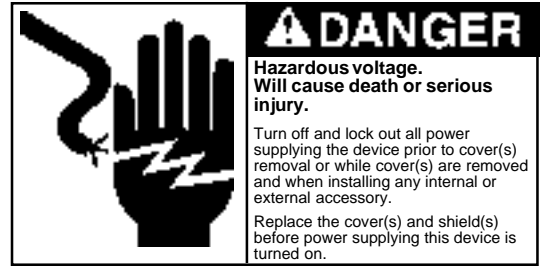

Installation Instructions

8. After properly orienting and mounting the neutral sensing transformer, maintain the correct polarity by connecting terminal LT11 on the circuit breaker to terminal X1 on the neutral sensor and terminal LT12 on the circuit breaker to terminal X2 on the neutral sensor.

N20STD

<u>Hardware List</u>	<u>Quantity</u>
10-32 Terminal Screw	2
Cupped Washer	2
Breaker label	1

Breaker Label (Figures 1 and 2)

This label is to be attached to the associated circuit breaker at installation. It should be located on the left side of the breaker cover next to the other accessory labels.

N25STD, N32STD

<u>Hardware List</u>	<u>Quantity</u>
10-32 Terminal Screw	2
Cupped Washer	2
L-mounting bracket	2
1/4-20 x 5/8 machine screw	4
1/4" lockwasher	4
Breaker label	1

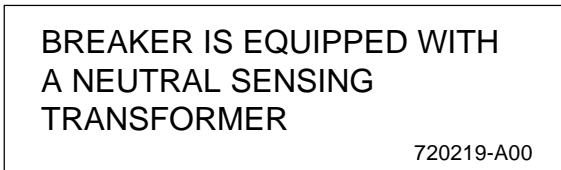

Figure 2

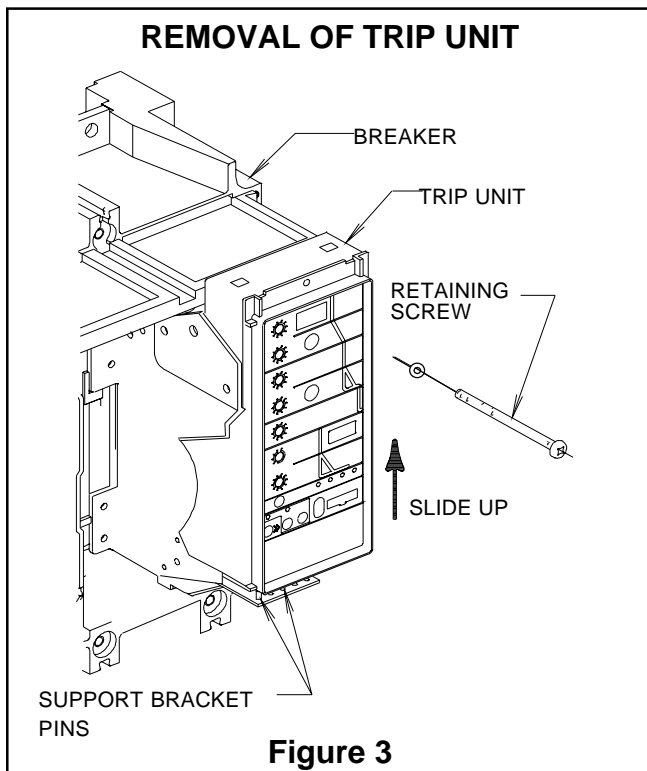

Figure 3

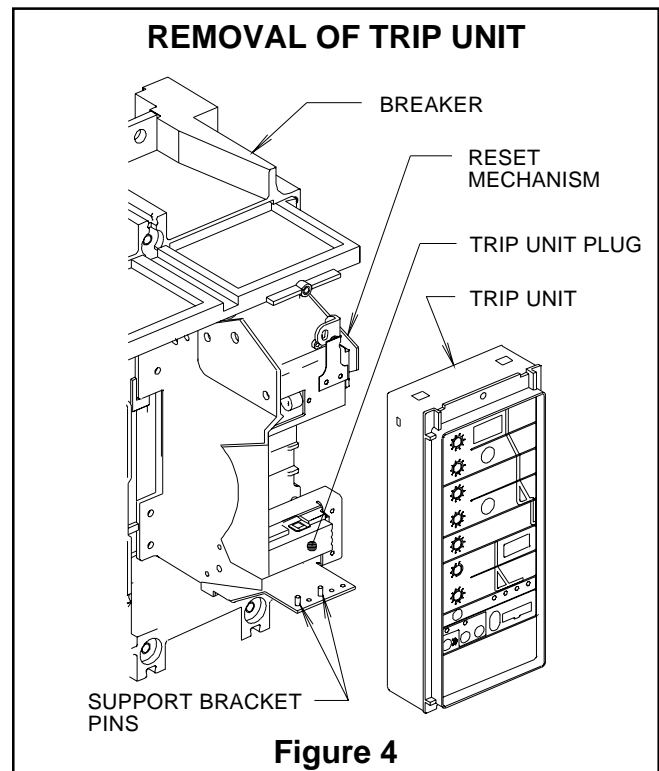



Figure 4



⚠ DANGER

Hazardous voltage.
 Will cause death or serious injury.

Turn off and lock out all power supplying the device prior to cover(s) removal or while cover(s) are removed and when installing any internal or external accessory.

Replace the cover(s) and shield(s) before power supplying this device is turned on.

Installation Instructions

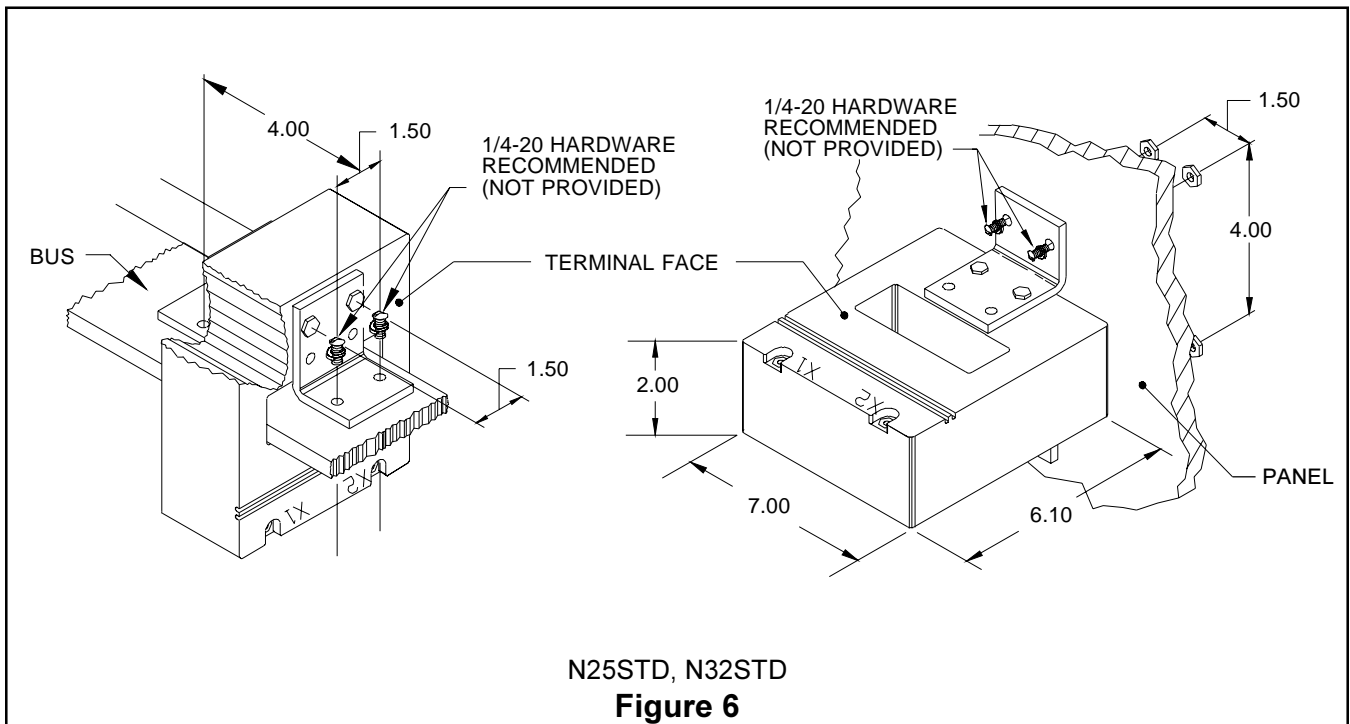
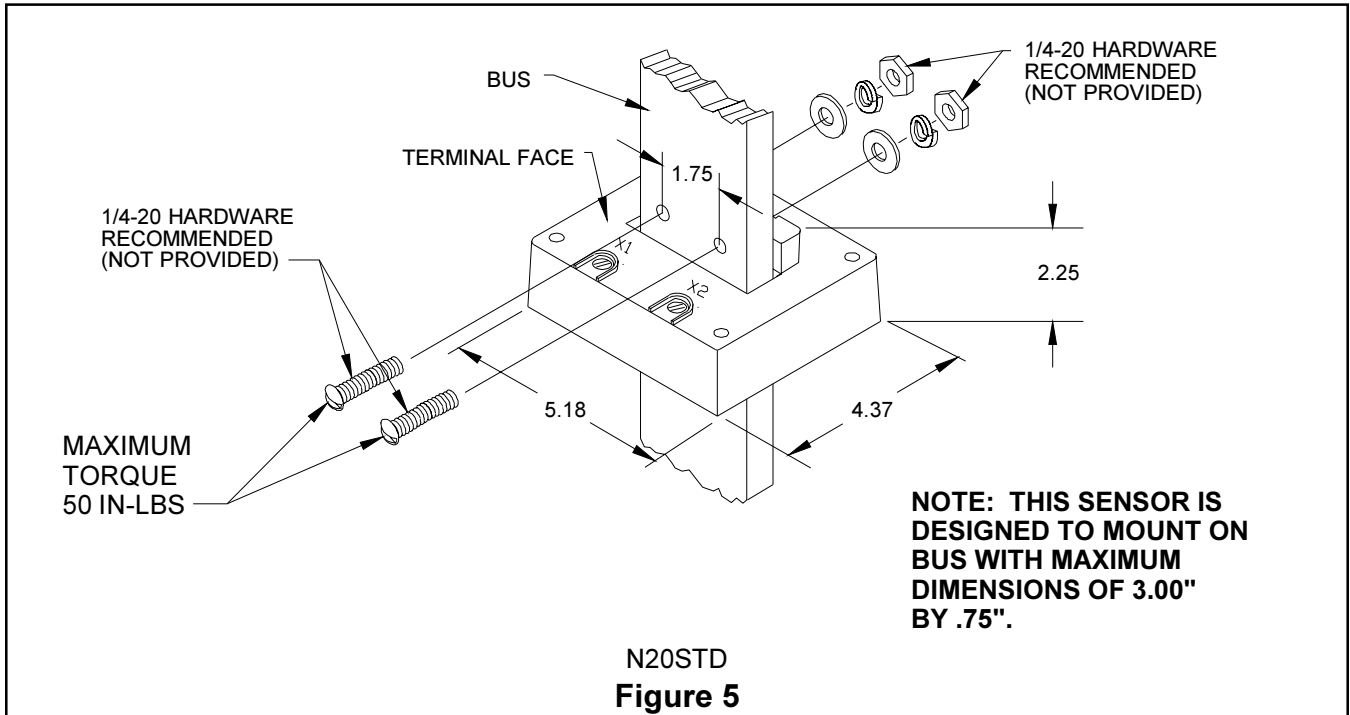



Installation Instructions

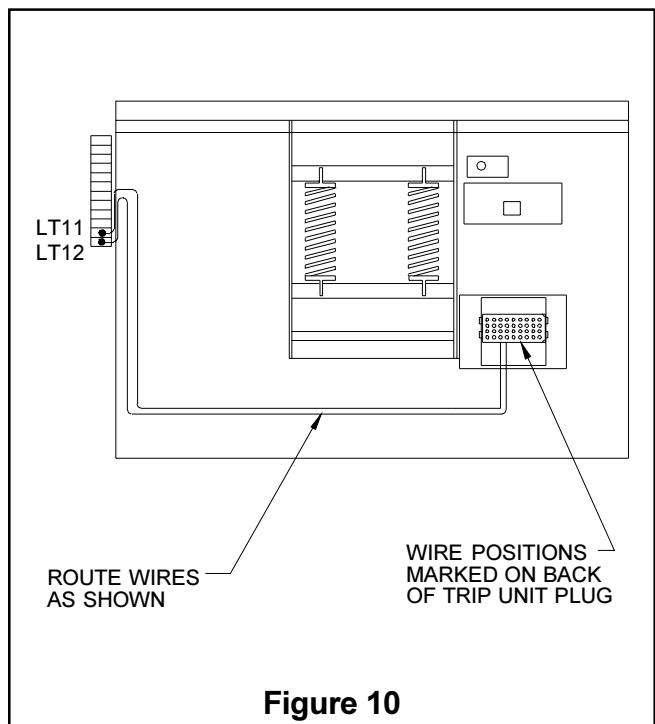
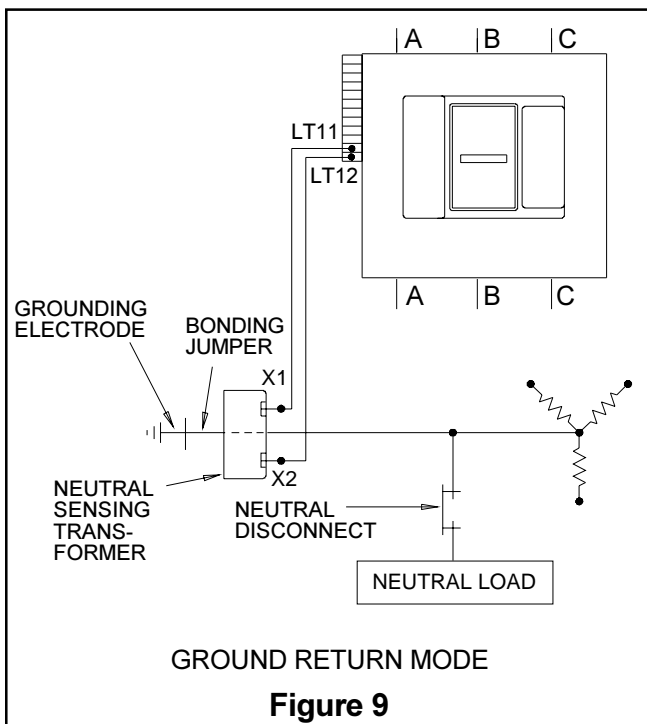
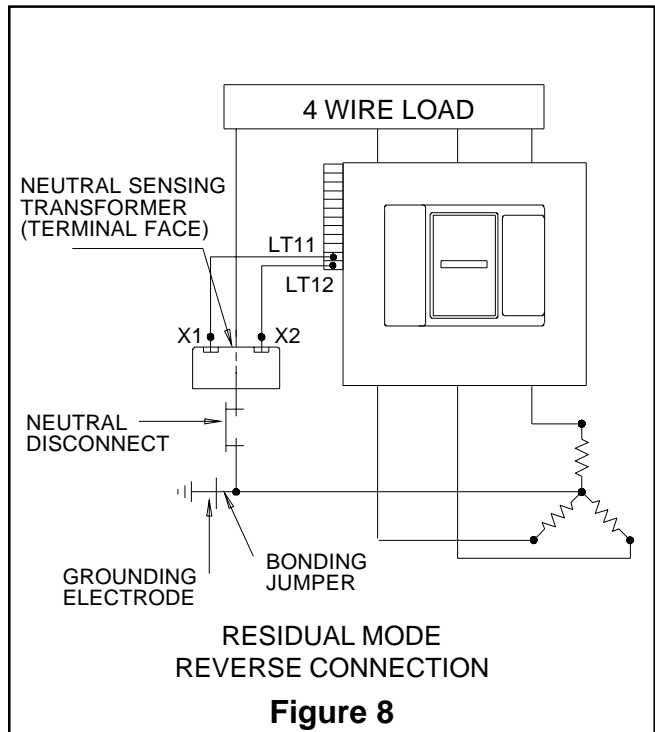
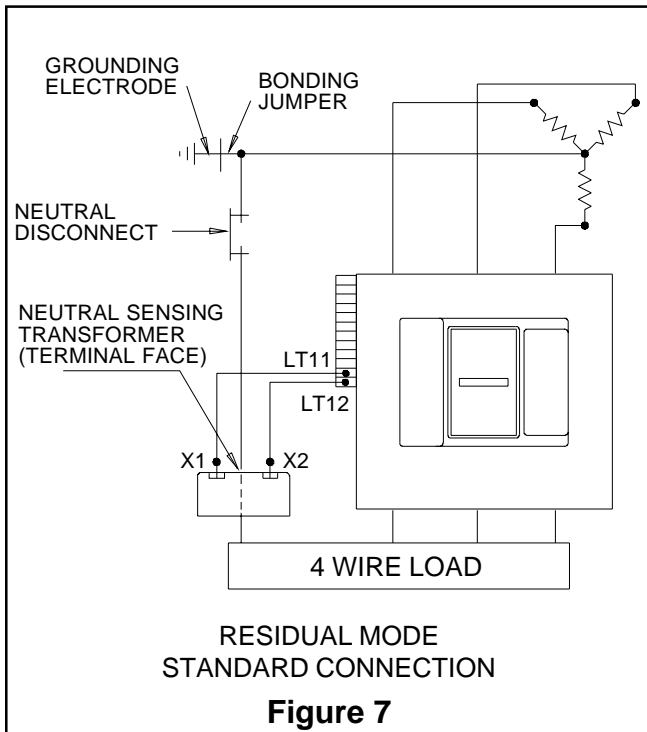

External Accessories

MT and Expansion Plug for Siemens ACCESS Communications System



⚠ DANGER
Hazardous voltage.
Will cause death or serious injury.
Turn off and lock out all power supplying the device prior to cover(s) removal or while cover(s) are removed and when installing any internal or external accessory.
Replace the cover(s) and shield(s) before power supplying this device is turned on.

⚠ Safety Instructions

Introduction

The Expansion Plug (EP) is an interface module used to interface the STD trip units to the Multiplexer Translator (MT).

The Siemens MT is a microprocessor-controlled device for configuring and controlling a Zone Interlock or ACCESS communications network. The flexibility provided by MT allows the user to configure the Zone Interlock or ACCESS communications network.

The model MTZ provides Zone Selective Interlocking only. The model MTA provides ACCESS communications in addition.

Refer to the device's individual instruction sheets for the connection of MTA, MTZ and EP devices.



Installing Sensitrip™ and SB Electronic Trip Units In Zone Selective Interlocking or ACCESS™ Communications Systems

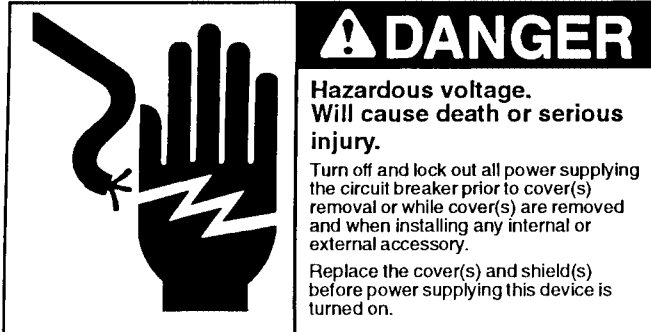

Introduction

This Instruction Sheet provides the component selection, cabling and interconnect information to configure Siemens Sensitrip MCCB, STD, and SB Systems Breaker ICCB's in either a Zone Selective Interlocking (ZSI) network or in an ACCESS™ communications system. Installed ICCB SB breakers without communication capability may be field upgraded by Siemens Field Service personnel only. MCCB breakers may be field upgraded by Siemens Field Service or the end user. Refer to Figure 1 for a diagram of the possible interconnect schemes described in the following scenarios .

Referenced Publications

The following publications are referenced in this instruction sheet, with the latest versions obtainable through the local Siemens sales office:

- _ ACCESS™ Systems Installation Guide [Manual SG-6028-01]
- _ Isolated Multi-Drop RS-232 to RS-485 Converter, Operator's Manual [Manual SG-6048-01]
- _ Multiplexer Translator (MT), Information and Instruction Guide [Bulletin 2.21-1A]
- _ Expansion Plug for Siemens Multiplexer Translator, Information and Instruction Sheet [Bulletin 2.21-2A]
- _ Electronic Trip Unit for SB Encased Systems Breakers, Information and Instruction Guide [Bulletin 2.20-3A]
- _ Sentron Systems Breaker, Energy Communicating Trip Unit, Information and Instruction Guide [Bulletin IPIM-2208]

Referenced Components

The following components are referenced in this instruction sheet, with the latest versions obtainable through the local Siemens sales office:

- Siemens **MTZ** (Multiplexer Translator, Zone Interlock) [Cat. No. **MTZ**] – a microprocessor-based device required for configuring and controlling a Zone Selective Interlocking (ZSI) network of up to eight (8) Sensitrip or SB circuit breakers; multiple MTs may be interconnected for a total of 31 MT's and 248 breakers.
- Siemens **MTA** (Multiplexer Translator, ACCESS) [Cat. No. **MTA**] – a microprocessor-based device for configuring and controlling up to eight (8) Sensitrip MCCB's and/or SB Trip Units within an ACCESS Communications System; multiple MTs may be interconnected for a total of 31 MT's and 248 breakers. The **MTA** also provides Zone Selective Interlocking capability. (Note: the SB-EC trip unit is direct ACCESS compatible but requires an **MTZ** or **MTA** for ZSI capability)
- Siemens type **EP** (Expansion Plug) - an isolation device to connect Sensitrip MCCB's, STD, and SB trip units to an **MTA** or **MTZ**. One (1) per trip unit when required.



Installing Sensitrip™ and SB Electronic Trip Units In Zone Selective Interlocking or ACCESS™ Communications Systems

Breaker Type	Frame Size	Mounting Type	Cat. No.
SB ICCB, STD	1200A, 2000A	Fixed	EPSBFMK ①
		Drawout	EPSBDMK ①
SB ICCB, STD	3200A, 5000A	Fixed	EPSB4FMK ①
		Drawout	EPSB4DMK ①
Sensitrip MCCB	ALL	ALL	EP

① Factory wired when ACCESS communications or ZSI is ordered for the SB breaker from the factory.

- Siemens **EPC** Ribbon Cable [Cat. No. **EPC##** (where: ## = 08, 12, or 18 inches)] – a 16-conductor cable used to connect the Sensitrip MCCB to an **EP**; qty. of 1 per trip unit. Order longest standard length when unsure of application.
- Siemens **MTC** 4-Wire Telephone Cable [Cat No. **MTC##** (where: ## = 08, 15, 25, or 50 feet)] – a 4-conductor phone cable, with a male RJ11 connector on each end, to connect an **EP** to an **MT** for Sensitrip MCCB applications or to connect adjacent **MT**s together. **MTC** cables may be special ordered in alternate lengths up to 100 feet. Order longest standard length when unsure of application.
- Siemens **MTCSB** 4-Wire to RJ11 Cable [Cat. No. **MTCSB##** (where: ## = 8, 15, 25, or 50 feet)] – a 4-conductor phone cable with a male RJ11 connector on one end and 4 spade lugs on the other end; used with SB Trip Units with rear connected, factory installed **EPSB** expansion plugs; Used to connect an **MT** to the factory installed **EPSB** expansion plug via the SB breaker secondary terminals or sliding disconnects. **MTCSB** cables may be special ordered in alternate lengths up to 100 feet. Order longest standard length when unsure of application.
- Siemens Isolated Multi-Drop Converter [Cat. No. 18-658-852-537] – an optional device used to convert four (4) RS-485 communications loops to one (1) RS-232 port for host PC communications.

Sensitrip MCCB Breakers

All Siemens Sensitrip Molded Case Circuit Breakers have the capability to function in both a ZSI network and within an ACCESS™ communications system. A separate device, the Siemens Multiplexer Translator, enables up to eight (8) breakers to communicate in either a ZSI-only scheme (via an **MTZ**), or in an ACCESS™ communications system (via an **MTA**) plus ZSI capability. The following scenarios describe the steps and accessories required to configure these types of systems:

A. Sensitrip MCCB Zone Selective Interlocking (only)

Components Required:

- Siemens **MTZ** - one per 8 trip units
- Siemens **EP** expansion plug - one per trip unit
- Siemens type **EPC** cable - one per trip unit
- Siemens type **MTC** cable - one per trip unit

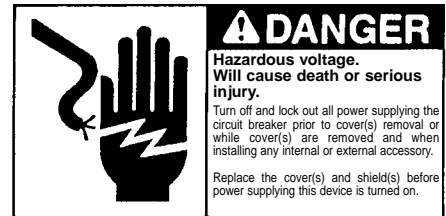

Installing Sensitrip™ and SB Electronic Trip Units In Zone Selective Interlocking or ACCESS™ Communications Systems

Installation:

1. Connect an **EPC** ribbon cable from the front of the Sensitrip Trip Unit's Test Connector to an **EP**; note that the connector is keyed, so that it can only be inserted one way.
2. Based on the site's coordination study, configure the **EP**'s DIP switches for Short Time and/or Ground Fault ZSI per the **EP** Information and Instruction Sheet.
3. Connect an **MTC** cable from the **EP** to one of eight **MTZ** communication ports.
4. Configure the **MTZ**'s DIP switches to identify the zones for each breaker, per the site's coordination study and the **MTZ** instruction sheet.
5. If multiple **MT**'s are used, the "Com" terminal from the first **MT**'s "SEABus Out" port must be connected to the "Com" terminal of the next **MT**'s "SEABus In" port on each **MT** being used.
6. See figure 1 for system connection diagram.

B. Sensitrip MCCB ACCESS Communications (with or without Zone Interlocking)

Components Required:

- Siemens **MTA** - one per 8 trip units
- Siemens **EP** expansion plug - one per trip unit
- Siemens type **EPC** cable - one per trip unit
- Siemens type **MTC** cable – one per trip unit

Installation:

1. Connect an **EPC** ribbon cable from the front of the Sensitrip Trip Unit's Test Connector to an **EP**; note that the connector is keyed, so that it can only be inserted one way.
2. If ZSI is required, configure per the site's coordination study, and configure the **EP**'s DIP switches for Short Time and/or Ground Fault ZSI per the **EP** Information and Instruction Sheet. If ZSI is not required, adjust the **EP**'s DIP switches to 'NO ZONE' (0000).
3. Connect an **MTC** cable from the **EP** to one of eight **MTA** communication ports.
4. If ZSI functionality is additionally required, per the site's coordination study, configure the **MTA** to identify the zones for each breaker according to the **MTA**'s instruction sheet. If multiple **MT**'s are used, the "Com" terminal from the first **MT**'s "SEABus Out" port must be connected to the "Com" terminal of the next **MT**'s "SEABus In" port on each **MT** being used.
5. If ZSI is not required, set the **MTA**'s Device Configuration DIP switches to 'NO ZONE' (00) and the **MTA**'s Device Type DIP switch to 'MCCB/ICCB' (0001).
6. Connect RS-485 twisted pair communication cable to the **MTA**'s A(+), B(-) terminals and only one end of the cable's shield to the **MT**'s GND terminal. Configure the ACCESS system network, per *Installing the ACCESS System* manual. An Isolated Multidrop Converter may be installed as an option. See figure 1 for system connection diagram.

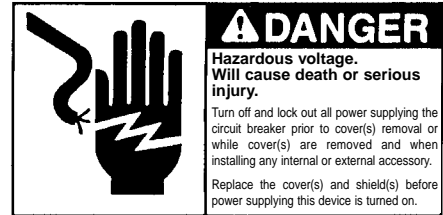

Installing Sensitrip™ and SB Electronic Trip Units In Zone Selective Interlocking or ACCESS™ Communications Systems

SB and STD Breakers

The following sections describe both types of SB and STD trip units, the standard Type 'TL' unit with rotary switches, and the SB Energy-Comm (SB-EC) Trip Unit with keypad and display. Since the SB-EC Trip Unit has integral communications capability, the **MTA** device is *not* required to connect within an ACCESS system, however for SB-EC Trip Units in a ZSI system, an **MTZ** or **MTA** is required.

The type **EPSB** expansion plug is factory wired to the SB breaker trip unit's rear connector and also located near and wired to the SB breaker's secondary terminal block for fixed mounted breakers or sliding disconnects for drawout breakers. These connections are factory wired when the SB breaker and or STD breaker is ordered with the standard switch based type 'TL' trip unit for ACCESS Communications or for any trip unit with ZSI capability.

Installed ICCB SB or STD breakers without communication capability may be field upgraded for communication capability by Siemens Field Service personnel only.

The **MTCSB** cable is used to connect an **MTA** or **MTZ** to an **EPSB** expansion plug via the SB or STD breaker secondary terminal block or sliding disconnect.

A. SB Breaker Zone Selective Interlocking (only)

1. All SB and STD Breaker Trip Units

Components Required:

- Siemens type **MTZ** - one per 8 trip units
- Siemens type **EPSB** expansion plug - one per trip unit, factory wired
- Siemens type **MTCSB** cable - one per trip unit

Installation:

1. When the factory-installed ZSI option is present, the **EPSB** expansion plug is already wired to the breaker and secondary control terminals. Connect an **MTCSB** cable's spade lugs from the appropriate breaker's secondary terminals (LB9, 10, 11, & 12) to one of eight communication inputs on the **MTZ**.
2. If multiple **MTZ**s are used, the "Com" terminal from the first **MTZ**'s "SEABus Out" port must be connected to the "Com" terminal of the next **MTZ**'s "SEABus In" port on each **MTZ** being used.
3. Based on the site's coordination study, configure the expansion plug's DIP switches for Short Time and/or Ground Fault ZSI per the **EP** Information and Instruction Sheet.
4. Configure the **MTZ** to identify the zones for each breaker, per the site's coordination study and information and instruction sheet. Refer to figure 1 for system connections diagram.

B. SB and STD Breaker ACCESS Communications (With or without Zone Interlocking)

1. Standard type 'TL' switch-based trip unit

Components Required:

- Siemens type **MTA** - one per 8 trip units
- Siemens type **EPSB** expansion plug - one per trip unit, factory wired
- Siemens type **MTCSB** cable - one per trip unit



Installing Sensitrip™ and SB Electronic Trip Units In Zone Selective Interlocking or ACCESS™ Communications Systems

Installation:

1. When the factory-installed ACCESS communications option is present, the **EPSB** expansion plug is already wired to the breaker and secondary control terminals. Connect an **MTC** cable's spade lugs to the appropriate breaker's secondary terminals (LB9, 10, 11, & 12) then to one of eight communication inputs on the **MTA**.
2. If ZSI functionality is additionally required, per the site's coordination study, configure the expansion plug's DIP switches for Short Time and/or Ground Fault ZSI per the expansion plug's Information and Instruction Sheet. Configure the **MTA** to identify the zones for each breaker, per the site's coordination study and the **MTA**'s instruction sheet.
3. If multiple **MT**'s are used, the "Com" terminal from the first **MT**'s "SEABus Out" port must be connected to the "Com" terminal of the next **MT**'s "SEABus In" port on each **MT** being used.
4. If ZSI is not required, set the expansion plug's DIP switches to NO ZONE (0000), the **MTA**'s Device Configuration DIP switches to NO ZONE (00) and the Device Type **MTA**'s DIP switch to MCCB/ICCB (0001).
5. Connect RS-485 twisted pair communication cable to the **MTA**'s A(+) and B(-) terminals. Connect only one end of the cable's shield to the **MT**'s GND terminal. Configure the ACCESS system network, per *Installing the ACCESS System* manual. An Isolated Multidrop Converter may be installed as an option. See figure 1 for system connection diagram.

2. SB-EC Trip unit

Since the SB-EC Trip Unit has direct communications with an ACCESS network, no intermediate devices are required unless ZSI functionality is required.

If ZSI is required, connect as per above using an **MTA** if type 'TL' SB breaker trip units or Sensitrip MCCB trip units are part of the overall system and both ACCESS communications and ZSI are required. Any application requiring only ZSI requires an **MTZ** configured as above.

If multiple **MT**'s are used for ZSI functionality, the "Com" terminal from the first **MT**'s "SEABus Out" port must be connected to the "Com" terminal of the next **MT**'s "SEABus In" port on each **MT** being used.

As referenced in the SB-EC Trip Unit Information and Instruction Manual, the trip unit's ACCESS communication lines are located on the breakers secondary control terminals <LB5> to RS485(+), <LB6> to RS-485(-), and <LB7> to Shield/Common. Refer to figure 1 for system connection diagram.

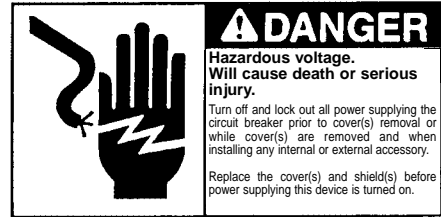

**Installing Sensitrip™ and SB Electronic Trip Units In Zone
Selective Interlocking or ACCESS™ Communications Systems**

Summary

The following table summarizes the required *Component Types* per each trip unit in the system. One component per trip unit unless otherwise noted:

Component Selection Guide^①

Component Type	Trip Units and Application				
	ZSI (only) with Sensitrip MCCB's	ACCESS and/or ZSI with Sensitrip MCCB's	ZSI (only) with all SB-EC Trip Units	ACCESS and/or ZSI with SB-TL Trip Units	ACCESS with SB-EC Trip Units
EP	✓	✓			
EPSB			✓	✓	
MTZ ^②	✓		✓		
MTA ^②		✓		✓	
EPC Cable	✓	✓			
MTC Cable ^③	✓	✓			
MTC SB Cable			✓	✓	

- ①When ordered with circuit breaker from the factory.
- ②One MTA or MTZ per eight trip units when required.
- ③Always required when multiple MT's are used. One additional cable per each additional MT.

Notes:

1. It is recommended that for long, single-ended runs (over 1000 ft.), that a 120 ohm, 1/4 watt terminating resistor between the Data+ and Data- terminals of the furthest devices be added. Adding a terminator resistor is not an absolute requirement, but using it will minimize reflected interference on the communication bus.
2. Both loop and straight RS-485 topologies are acceptable. The advantage of the straight topology is further distance to the last device (4000 ft.) The advantage to the loop topology is that the devices will continue to communicate even with a break in the line. The disadvantage of the loop topology is the distance to the furthest device is only 2000 ft.
3. A Siemens Isolated Multi-Drop Converter [Cat. No. 18-658-852-537] may be used as an optional device used to convert four (4) RS-485 communications loops to one (1) RS-232 port for host PC communications.
4. Protocol converters are available from the Siemens ACCESS group to provide plug-and-play capability with over 25 different PLC protocols (Siemens S7, Modbus, etc.), Profibus, DeviceNet, and LonWorks.
5. If multiple MT's are used for ZSI applications, the "Com" terminal from the first MT's "SEABus Out" port must be connected to the "Com" terminal of the next MT's "SEABus In" port on each MT being used.
6. Installed ICCB SB breakers without communication capability may be field upgraded by Siemens Field Service personnel only. MCCB breakers may be field upgraded by Siemens Field Service or the end user.
7. Refer to Installing the ACCESS™ System Installation Guide [Manual SG-6028-01] for proper system shield and grounding connections schemes.

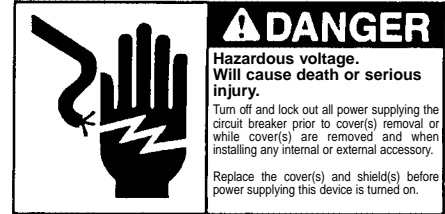

**Installing Sensitrip™ and SB Electronic Trip Units In Zone
 Selective Interlocking or ACCESS™ Communications Systems**

Figure 1 - System Connection Diagram

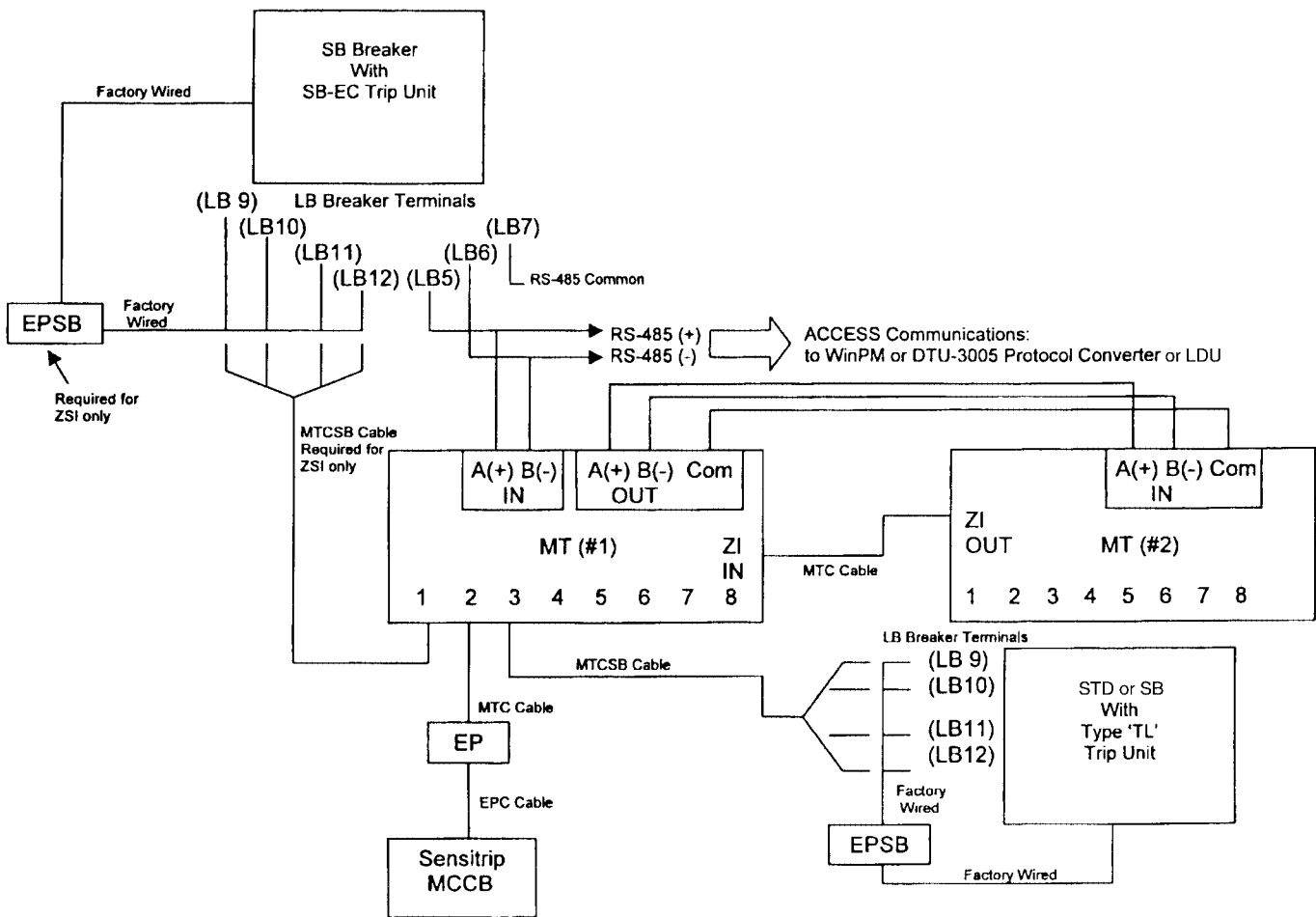

External Accessories

Universal Test Kit (TS-31)

General Information

(detailed instructions supplied with kit)



⚠ DANGER
Hazardous voltage.
Will cause death or serious injury.
Turn off and lock out all power supplying the device prior to cover(s) removal or while cover(s) are removed and when installing any internal or external accessory.
Replace the cover(s) and shield(s) before power supplying this device is turned on.

⚠ Safety Instructions



Universal Test Kit

General

The TS-31 is a universal test kit to check the tripping functions of Siemens electronic trip units. It functions by injecting current into the current transformer circuits via a test port on the front of the trip unit.

Operations:

See the specific TS-31 instructions, furnished with the unit, for detailed operating instructions. One exception to those instructions pertains to the STD trip unit.

The early TS-31 internal firmware may not recognize STD trip unit catalog numbers. Consequently, you must enter SB trip unit numbers according to the following substitution table.

For this STD Trip Unit Catalog Number	Substitute this SB Trip Unit Catalog Number
STD20TLS	SB20TLS
STD20TLI	SB20TLI
STD20TLSI	SB20TLSI
STD20TLSG	SB20TLSG
STD20TLIG	SB20TLIG
STD20TLSIG	SB20TLSIG
STD25TMLI	SB25TMLI
STD25TLS	SB25TLS
STD25TLI	SB25TLI
STD25TLSI	SB25TLSI
STD25TLSG	SB25TLSG
STD25TLIG	SB25TLIG
STD25TLSIG	SB25TLSIG
STD32TMLI	SB32TMLI
STD32TLS	SB32TLS
STD32TLI	SB32TLI
STD32TLSI	SB32TLSI
STD32TLSG	SB32TLSG
STD32TLIG	SB32TLIG
STD32TLSIG	SB32TLSIG

External Accessories

Auxiliary Power Supply

	⚠ WARNING
	Trip Free Condition. Misoperation or mechanism damage can occur if incorrectly tested. Release power button on APM before closing breaker mechanism.

Auxiliary Power Supply

The Auxiliary Power Supply (APS) is used for bench testing the Electronic Trip Unit. The supply may also be used to power the trip unit during the execution of a "go/no-go" type test before bringing the STD breaker on-line (see Monitoring the Trip Unit in the Operating Instructions section). The auxiliary power supply operates from 120V AC source power.



Auxiliary Power Source

Test Procedures

1. Remove the clear cover from Trip Unit.
2. To test trip unit, plug the APM into the front of the trip unit.
3. Hold down the Power button on the APM and the desired test buttons on the trip unit. Note that only the Powerbutton must be held down for the duration of the test sequence. If the Power button is released, the test must be restarted.
4. After trip unit test is complete, release the Power button on the APM.
5. Reinstall the clear cover.

Outline Dimension Drawing

STD 3200A

HANDLE FORCES		
OPERATING FORCE	WITHOUT EXTENSION	WITH EXTENSION
OFF TO ON	120 LB.	70 LB.
ON TO OFF	72 LB.	33 LB.
TRIPPED TO RESET	52 LB.	30 LB.

NOTES:

1. MOUNTING BOLT TORQUE IS 15 FT - LBS. MAXIMUM

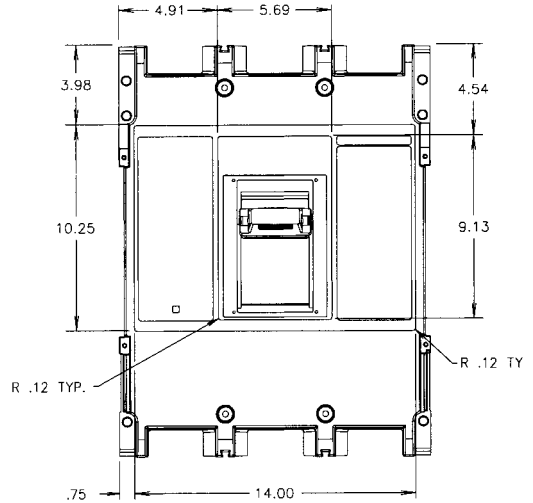
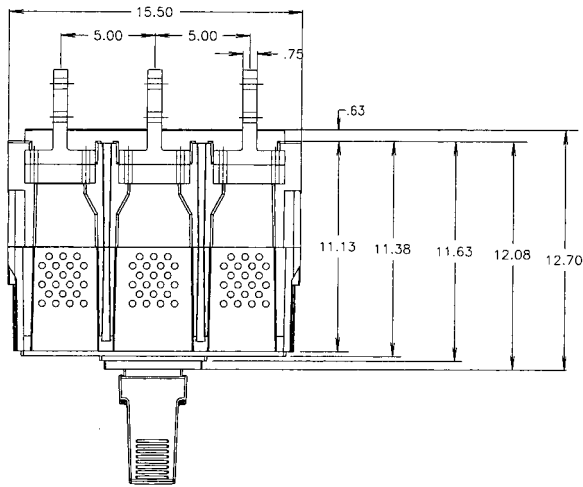

ESCUTCHEON DIMENSIONS

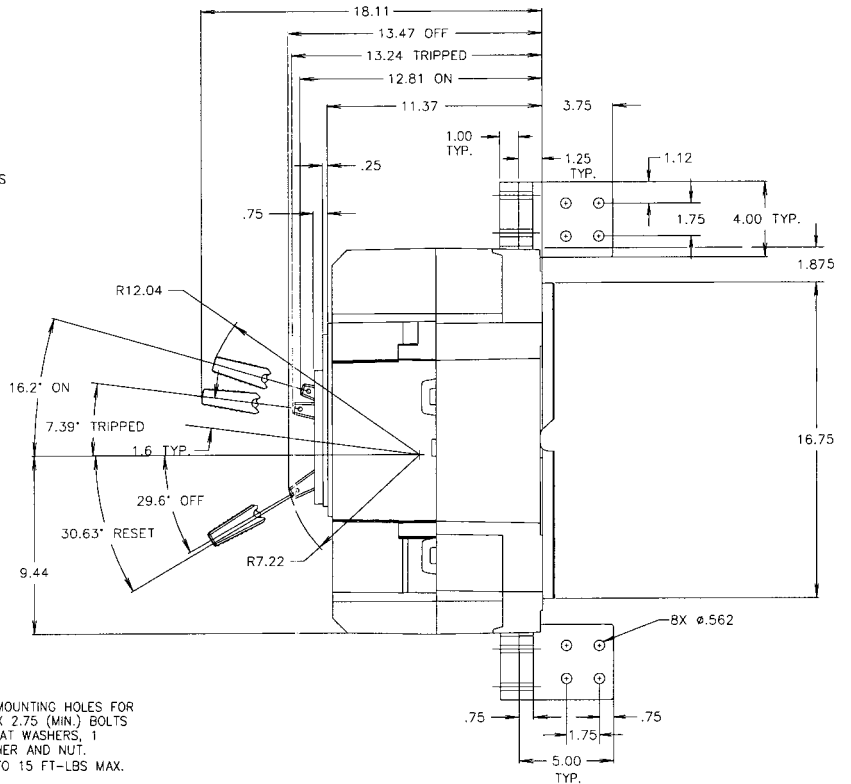
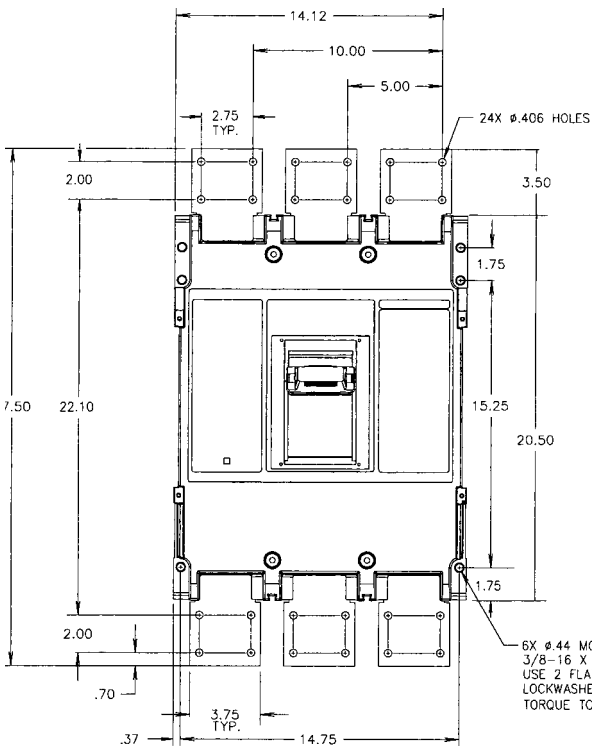

Ordering Information ①

Frames and Trip Units

FRAMES

Amperage	Standard Interrupting	High Interrupting	Extra High Interrupting
2000	STD63F2000	SHTD63F2000	SHHTD63F2000
2500	STD63F2500	SHTD63F2500	SHHTD63F2500
3200	STD63F3200	SHTD63F3200	SHHTD63F3200

100% RATED

Amperage	Standard Interrupting	High Interrupting	Extra High Interrupting
2000	STD63F2000H	SHTD63F2000H	SHHTD63F2000H
2500	STD63F2500H	SHTD63F2500H	SHHTD63F2500H
3200	STD63F3200H	SHTD63F3200H	SHHTD63F3200H

TRIP UNITS

	Ampere Frame Rating	Continuous Current Pickup	Long Time Delay	Short Time Pickup/Delay	Instantaneous Pickup	Ground Fault Pickup/Delay
STD20TMLI	2000	Plug	F	—	X	—
STD20TLS		X	X	X	—	—
STD20TLI		X	X	—	X	—
STD20TLSI		X	X	X	X	—
STD20TLSG		X	X	X	—	X
STD20TLIG		X	X	—	X	X
STD20TLSIG		X	X	X	X	X
STD25TMLI	2500	Plug	F	—	X	—
STD25TLS		X	X	X	—	—
STD25TLI		X	X	—	X	—
STD25TLSI		X	X	X	X	—
STD25TLSG		X	X	X	—	X
STD25TLIG		X	X	—	X	X
STD25TLSIG		X	X	X	X	X
STD32TMLI	3200	Plug	F	—	X	—
STD32TLS		X	X	X	—	—
STD32TLI		X	X	—	X	—
STD32TLSI		X	X	X	X	—
STD32TLSG		X	X	X	—	X
STD32TLIG		X	X	—	X	X
STD32TLSIG		X	X	X	X	X
X :Adjustable via dial and rating plug F :Fixed Plug :Changeable with rating plug only — :Not applicable			An example of an STD Breaker order is: 2000A Frame Breaker (STD63F2000), Trip Unit for 2000A Frame Breaker (STD20TLS), and a 1000A continuous current Rating Plug for a 2000A Frame Breaker (20STD1000).			

① See Bulletin IPPS-0284A for complete ordering information for accessories.



Siemens Energy & Automation, Inc.

3333 Old Milton Parkway
Alpharetta, GA 30005

1-800-964-4114

seainfo@sea.siemens.com

www.siemens.automation.com

© 2002 Siemens Energy & Automation, Inc. All Rights Reserved

Siemens is a registered trademark of Siemens AG. Product names mentioned may be trademarks or registered trademarks of their respective companies. Specifications are subject to change without notice.

Order # IPIM-0283B 0800B&A