

ebm-papst Mulfingen GmbH & Co. KG

Bachmühle 2 · D-74673 Mulfingen

Phone +49 7938 81-0

Fax +49 7938 81-110

info1@de.ebmpapst.com

www.ebmpapst.com

Limited partnership · Headquarters Mulfingen

Amtsgericht (court of registration) Stuttgart · HRA 590344

General partner Elektrobau Mulfingen GmbH · Headquarters Mulfingen

Amtsgericht (court of registration) Stuttgart · HRB 590142

Nominal data

Type	W3G630-NU33-03	
Motor	M3G150-IF	
Phase		3~
Nominal voltage	VAC	400
Nominal voltage range	VAC	380 .. 480
Frequency	Hz	50/60
Method of obtaining data		ml
Status		prelim.
Speed (rpm)	min ⁻¹	1800
Power consumption	W	3600
Current draw	A	5.5
Max. back pressure	Pa	440
Max. back pressure	in. wg	1.77
Min. ambient temperature	°C	-40
Max. ambient temperature	°C	60

ml = Max. load · me = Max. efficiency · fa = Free air · cs = Customer specification · ce = Customer equipment
Subject to change

Data according to Commission Regulation (EU) 327/2011 (EN 17166)

		Actual	Req. 2015			
01 Overall efficiency η_{es}	%	49.8	36.8	09 Power consumption P_{ed}	kW	3.17
02 Measurement category		A		09 Air flow q_v	m ³ /h	16530
03 Efficiency category		Static		09 Pressure increase p_{fs}	Pa	329
04 Efficiency grade N		53	40	10 Speed (rpm) n	min ⁻¹	1800
05 Variable speed drive		Yes		11 Specific ratio*		1.00

Data obtained at optimum efficiency level.

* Specific ratio = $1 + p_{fs} / 100\,000\text{ Pa}$

LU-205573

The efficiency values displayed for achieving conformity with the Ecodesign Regulation EU 327/2011 has been reached with defined air duct components (e.g. inlet rings).
The dimensions must be requested from ebm-papst. If other air conduction geometries are used on the installation side, the ebm-papst evaluation loses its validity/the conformity must be confirmed again.
The product does not fall within the scope of Regulation (EU) 2019/1781 due to the exception specified in Article 2 (2a) (motors completely integrated into a product).



Technical description

Weight	39.3 kg
Size	630 mm
Motor size	150
Rotor surface	Painted black
Electronics housing material	Die-cast aluminum, painted gray
Blade material	PP plastic
Fan housing material	Sheet steel, galvanized and coated with black plastic (RAL 9005)
Guard grille material	Steel, coated with black plastic (RAL 9005)
Number of blades	5
Blade pitch	0°
Airflow direction	V
Direction of rotation	Clockwise, viewed toward rotor
Degree of protection	IP55
Insulation class	"F"
Moisture (F) / Environmental (H) protection class	H2
Ambient temperature note	Occasional start-up at temperatures between -40°C and -25°C is permitted. For continuous operation at ambient temperatures below -25°C (such as refrigeration applications), use must be made of a fan design with special low-temperature bearings.
Max. permitted ambient temp. for motor (transport/storage)	+80 °C
Min. permitted ambient temp. for motor (transport/storage)	-40 °C
Installation position	Shaft horizontal or rotor on bottom; rotor on top on request
Condensation drainage holes	On rotor side
Mode	S1
Motor bearing	Ball bearing
Technical features	<ul style="list-style-type: none"> - Operation and alarm display with LED - External 15-50 VDC input (parameterization) - Alarm relay - Integrated PI controller - Configurable inputs/outputs (I/O) - MODBUS V6.3 - Motor current limitation - RS-485 MODBUS-RTU - Soft start - Voltage output 3.3-24 VDC, Pmax = 800 mW - Control interface with SELV potential safely disconnected from the mains - Thermal overload protection for electronics/motor - Line undervoltage / phase failure detection
Touch current according to IEC 60990 (measuring circuit Fig. 4, TN system)	<= 3.5 mA
Electrical hookup	Terminal box
Motor protection	Reverse polarity and locked-rotor protection
Protection class	I (with customer connection of protective earth)
Conformity with standards	EN 61800-5-1; CE
Approval	CSA C22.2 No. 77 + CAN/CSA-E60730-1; EAC; UL 1004-7 + 60730-1

EC axial fan - AxiBlade

sickle-shaped blades (S series)

Fan housing with guard grille

Product drawing

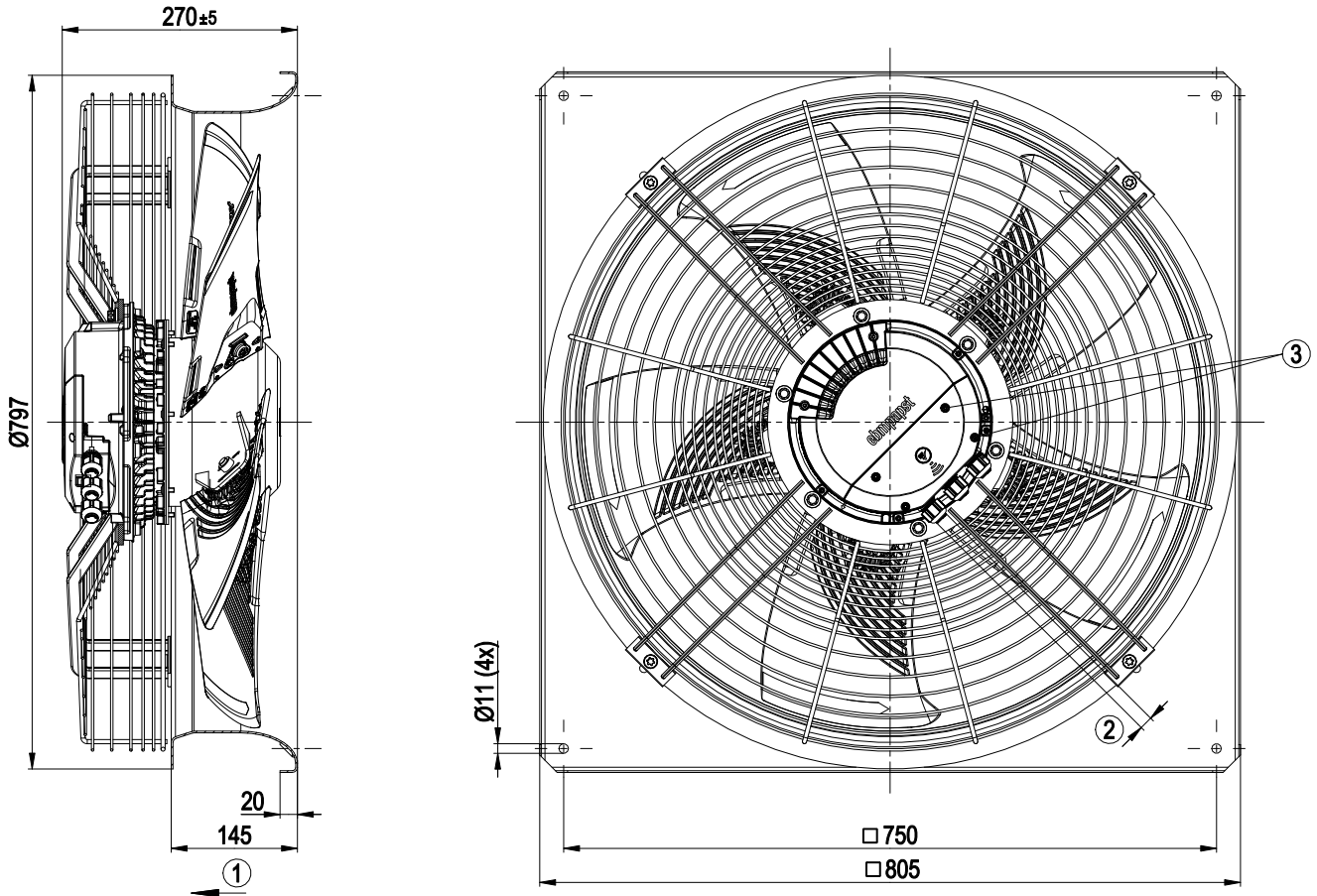

1	Airflow direction "V"
2	Cable diameter min. 4 mm, max. 10 mm, tightening torque 4 ± 0.6 Nm (The tightening torque is designed for PVC cables. If the cable materials are different, the tightening torque may have to be adjusted)
3	Tightening torque 1.5 ± 0.2 Nm



EC axial fan - AxiBlade

sickle-shaped blades (S series)

Fan housing with guard grille

Connection diagram

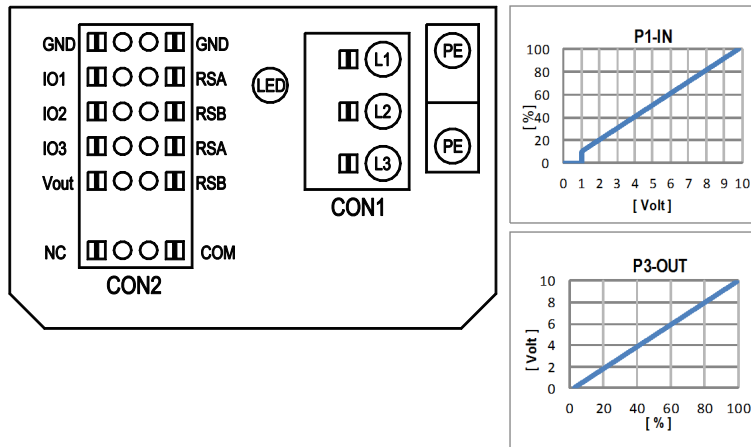

No.	Conn.	Designation	Function/assignment
	CON1	L1, L2, L3	Power supply, phase, see nameplate for voltage range
	PE	PE	Protective earth
	CON2	RSA	RS485 interface for MODBUS, RSA; SELV
	CON2	RSB	RS485 interface for MODBUS, RSB; SELV
	CON2	GND	Reference ground for control interface, SELV
	CON2	IO1	Function parameterizable (see "Optional interface functions" table) Factory setting: Digital input - high active, function: Disable input, SELV - inactive: Pin open or applied voltage < 1.5 VDC - active: applied voltage 3.5-50 VDC Reset function: Triggering of error reset on change of state from "enabled" to "disabled"
	CON2	IO2	Function parameterizable (see "Optional interface functions" table) Factory setting: Analog input 0-10 V / PWM, Ri=100 kΩ, function: Set value Characteristic curve parameterizable (see input characteristic curve P1-IN), SELV
	CON2	IO3	Function parameterizable (see "Optional interface functions" table) Factory setting: Analog output 0-10 V, max. 5 mA, function: Fan modulation level Characteristic curve parameterizable (see output characteristic curve P3-OUT), SELV
	CON2	Vout	Voltage output 3.3-24 VDC ±5%, Pmax=800 mW, voltage parameterizable Factory setting: 10 VDC short-circuit-proof, supply for external devices, SELV alternatively: 15-50 VDC input for parameterization via MODBUS without line voltage
	CON2	COM	Status relay, floating status contact, common connection, contact rating 250 VAC / 2 A (AC1) / min. 10 mA, reinforced insulation on supply side and on control interface side
	CON2	NC	Status relay, floating status contact, break for failure
		LED	green: status = good, ready for operation orange: status = warning red: status = failure
		P1-IN	Input characteristic curve
		P3-OUT	Output characteristic curve



EC axial fan - AxiBlade

sickle-shaped blades (S series)

Fan housing with guard grille

Terminal/plug assignment

CON2	configurable IO mode	electrical specification	configurable IO functions: normal / inverse	MODBUS Register for IO mode configuration	
				D158 [0]	D158 [2]
IO1	○ Din1 (active high), digital input	active: applied voltage 3.5-50VDC, SELV not active: pin open or applied voltage < 1.5VDC		○	
	○ Ain1 0-10V/PWM: analog input	RI = 100k, characteristic curve parameterizable, f _{PWM} = 1k..10kHz, SELV			
	○ Tach out (open collector output)	U _{max} = 50VDC, I _{max} = 20mA, SELV		○	
	○ Diagnostics out (open collector output)	U _{max} = 50VDC, I _{max} = 20mA, SELV			
IO2	○ Din2 (active high), digital input	active: applied voltage 3.5-50VDC, SELV not active: pin open or applied voltage < 1.5VDC		○	
	○ Ain2 0-10V/PWM: analog input	RI = 100k, characteristic curve parameterizable, f _{PWM} = 1k..10kHz, SELV			
	○ Ain2 4-20mA: analog input	RI = 125R, characteristic curve parameterizable, SELV		○	
	○ Din3 (active high), digital input	active: applied voltage 3.5-50VDC, SELV not active: pin open or applied voltage < 1.5VDC			
IO3	○ Din3 (active low), digital input	active: applied voltage < 1.5VDC, SELV not active: pin open or applied voltage 3.5-50VDC		○	
	○ PWMIn3: digital input, idle level high	PWM = 40Hz - 10kHz, characteristics parameterizable			
	○ PWMIn3: digital input, idle level low	active: pin open or applied voltage 3.5-50VDC not active: applied voltage < 1.5VDC, SELV		○	
	○ Aout3 0-10V: analog output	active: applied voltage 3.5-50VDC not active: pin open or applied voltage < 1.5VDC, SELV			
Vout	○ Tacho out (pulses), analog output	function parameterizable, max. 5mA max output frequency 300Hz, SELV			
	○ Diagnostics out (pulses)	0-10V/max. 5mA max output frequency 300Hz, SELV		○	
	○ Diagnostics out (pulses)	0-10V/max. 5mA max output frequency 300Hz, SELV			
RSA	RS485 bus connection,	MODBUS RTU, specification V6.3, SELV		○	
RSB	voltage output	voltage parameterizable 3.3...24VDC +/- 5%, P _{max} =800mW, short-circuit-proof, supply for external devices, SELV			
	alternatively: Input auxiliary power supply for parameterization via RS485/MODBUS RTU without line voltage	15...50VDC			
D101 [..]	source: set value		source: sensor value		
D147 [..]	switch: parameter set: #1 / #2		switch: control function: heating (pos.) cooling (neg.)		
D148 [..]	switch: direction of rotation: cw / ccw		switch: set value source		
D16C [..]	switch: fan enable / disable		switch: tach out		
D16A [..]	signal: diagnostics out		signal: fan modulation level %		
D130 [0]	signal: fan modulation level %		signal: actual speed		
D130 [2]	signal: system modulation level %		signal: remote control output 0-10V		
D130 [5]	signal: pulse input for auto-addressing		signal: pulse output for auto-addressing		
D00C [1]					
D130 [4]					



EC axial fan - AxiBlade

sickle-shaped blades (S series)

Fan housing with guard grille

Curves: Air performance 50 Hz

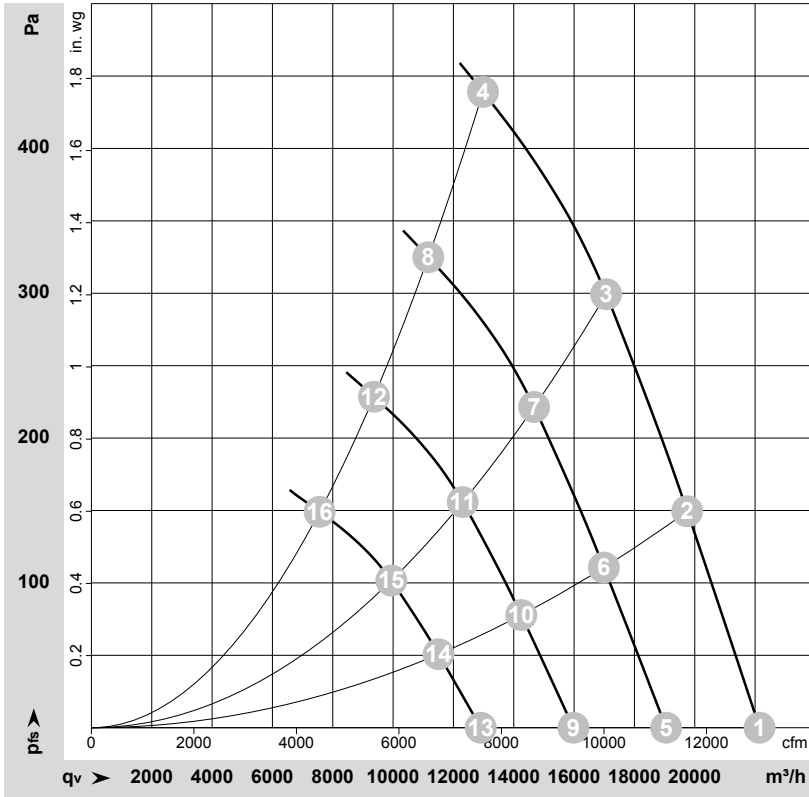

$\rho = 1.15 \text{ kg/m}^3 \pm 2 \%$

Measurement: LU-205573-1

Air performance measured according to ISO 5801 installation category A. For detailed information on the measurement setup, contact ebmpapst. Intake sound level: Sound power level according to ISO 13347 / sound pressure level measured at 1 m distance from fan axis. The values given are valid under the specified measuring conditions and may vary due to conditions of installation. For deviations from the standard configuration, the parameters have to be checked on the installed unit.

Measured values

	Wired	U	f	n	P _{ed}	I	LpA _{in}	LwA _{in}	LwA _{out}	q _v	p _{fs}	q _v	p _{fs}
		V	Hz	min ⁻¹	W	A	dB(A)	dB(A)	dB(A)	m ³ /h	Pa	cfm	in. wg
1	3~	400	50	1800	1991	3.12	78	86	87	22150	0	13035	0.00
2	3~	400	50	1800	2570	3.96	77	85	86	19750	150	11625	0.60
3	3~	400	50	1800	3090	4.72	80	87	88	17060	300	10040	1.20
4	3~	400	50	1800	3600	5.50	90	98	99	12980	440	7640	1.77
5	3~	400	50	1550	1267	1.98	75	82	83	19050	0	11215	0.00
6	3~	400	50	1550	1636	2.52	74	81	82	16985	112	10000	0.45
7	3~	400	50	1550	1967	3.01	76	83	84	14675	222	8635	0.89
8	3~	400	50	1550	2271	3.46	86	94	95	11165	325	6570	1.30
9	3~	400	50	1300	748	1.17	70	78	79	15980	0	9405	0.00
10	3~	400	50	1300	965	1.49	69	76	78	14245	79	8385	0.32
11	3~	400	50	1300	1160	1.77	71	78	79	12310	156	7245	0.63
12	3~	400	50	1300	1340	2.04	81	89	90	9365	229	5510	0.92
13	3~	400	50	1050	394	0.62	65	72	74	12905	0	7595	0.00
14	3~	400	50	1050	508	0.78	64	71	73	11510	51	6775	0.20
15	3~	400	50	1050	611	0.93	66	73	74	9940	102	5850	0.41
16	3~	400	50	1050	706	1.07	76	84	85	7565	149	4450	0.60

Wired = Wiring · U = Voltage · f = Frequency · n = Speed (rpm) · P_{ed} = Power consumption · I = Current draw · LpA_{in} = Sound pressure level intake side · LwA_{in} = Sound power level intake side
 LwA_{out} = Sound power level outlet side · q_v = Air flow · p_{fs} = Pressure increase

